



DCS GUIDE
DH.98 MOSQUITO FB MK VI

By Chuck
LAST UPDATED: 4/2/2022

TABLE OF CONTENTS

- PART 1 – INTRODUCTION
- PART 2 – CONTROLS SETUP
- PART 3 – COCKPIT & EQUIPMENT
- PART 4 – START-UP PROCEDURE
- PART 5 – TAXI & TAKEOFF
- PART 6 – LANDING
- PART 7 – ENGINE & FUEL MANAGEMENT
- PART 8 – AIRCRAFT LIMITATIONS
- PART 9 – AERODYNAMICS
- PART 10 – WEAPONS
- PART 11 – RADIOS
- PART 12 – NAVIGATION
- PART 13 – EMERGENCY PROCEDURES
- PART 14 – MULTICREW
- PART 15 – TACTICS AND AIR COMBAT
- PART 16 – OTHER RESOURCES

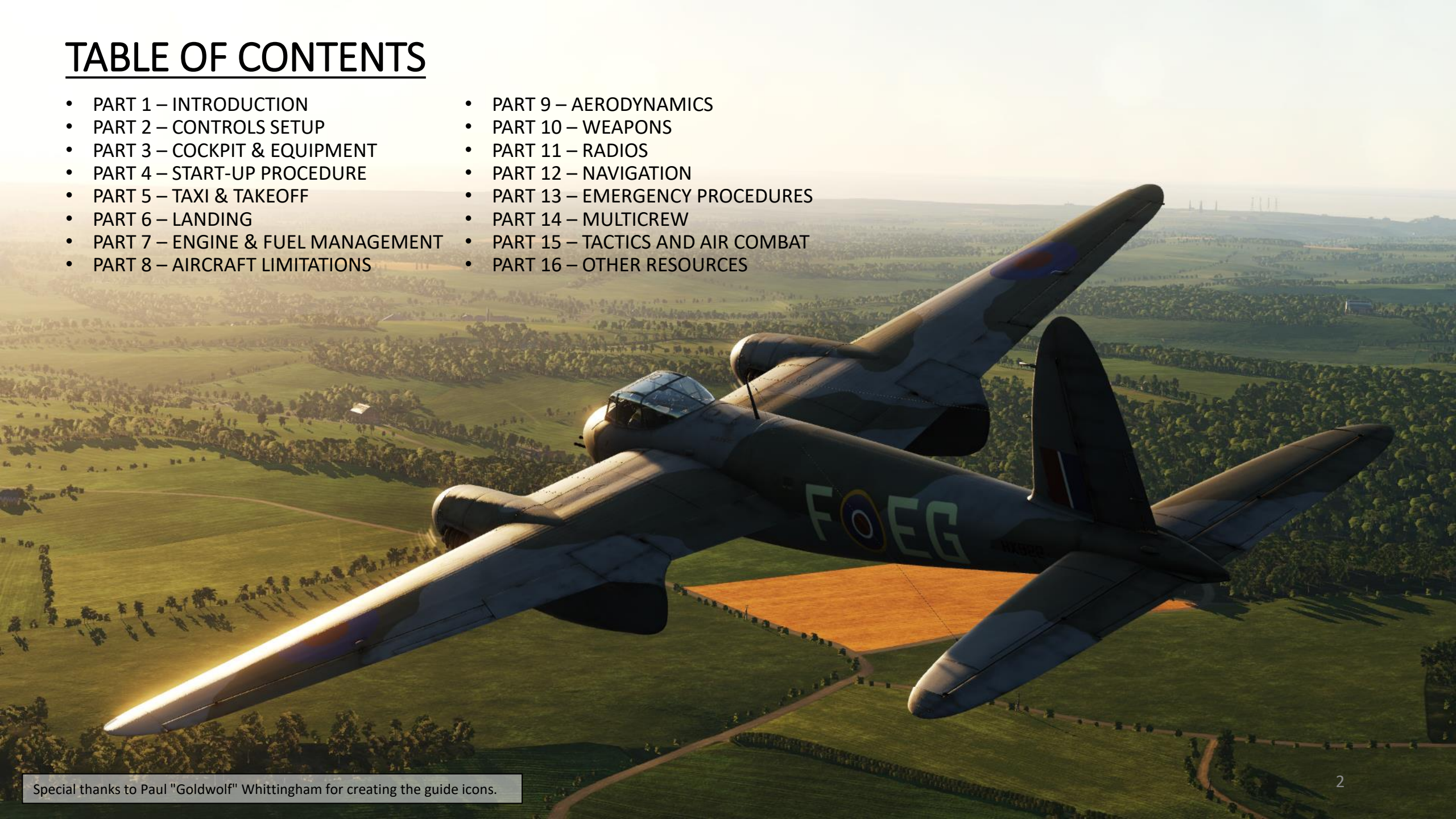

The **de Havilland DH.98 Mosquito** is a British twin-engine, multirole combat aircraft introduced during the Second World War. Its frame was constructed mostly of wood, and it was nicknamed the "Wooden Wonder", or the "Mossie". Lord Beaverbrook, Minister of Aircraft Production, nicknamed it "Freeman's Folly", alluding to Air Chief Marshal Sir Wilfrid Freeman, who defended Geoffrey de Havilland and his design concept against orders to scrap the project. By 1941, it was one of the fastest operational aircraft in the world.

Originally conceived as an unarmed fast bomber, the Mosquito's use evolved during the war into many roles, including low to medium altitude daytime tactical bomber, high-altitude night bomber, pathfinder, day or night fighter, fighter-bomber, intruder, maritime strike, and photo-reconnaissance aircraft. It was also used by the British Overseas Airways Corporation (BOAC) as a fast transport to carry small, high-value cargo to and from neutral countries through enemy-controlled airspace. The crew of two, pilot and navigator, sat side by side. A single passenger could ride in the aircraft's bomb bay when necessary.

The concept of the Mosquito was initially received with a lot of skepticism by the British Air Ministry. The fact that it was built out of wood instead of metal and the fact that it had no defensive turrets meant that the idea was a hard sell. Its design was unconventional, and Geoffrey de Havilland's sheer will and determination were instrumental in the adoption of this plane by the Royal Air Force. After all, he even pitched in some of his own money to develop the early prototypes. Once the test flights started, the prototypes proved him right: equipped with twin 1,460 horsepower Rolls Royce Merlin 21 engines, in February 1941 the Mosquito comfortably outran a Spitfire Mk II in level flight, reaching a top speed of 392 mph against the Spitfire's 360 mph. A star was born.

Speed was the name of the Mossie's game, and this is when Air Marshal Wilfred Freeman recognized its potential. On 21 June 1941, the Air Ministry authorized production of 19 Mosquito photo-reconnaissance (PR) models and 176 fighters. Orders for a fast medium bomber variant, the FB Mk. VI, quickly followed. Almost all production Mossies had four Hispano Mk II 20 mm cannon housed under the nose, with a further four Browning .303 inch machine guns ranged above those. Fitted with a bomb bay, the Mossie could also carry a 1,000 lbs payload over a range of more than 1,500 miles. Underwing rails also enabled it to strike with a salvo of eight rockets.

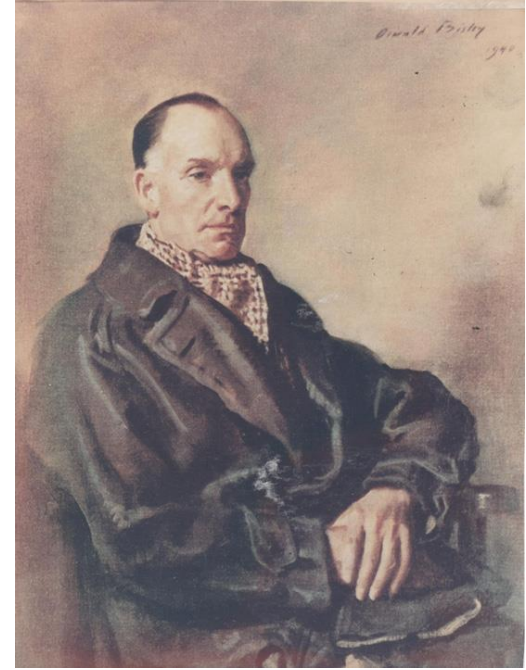

Geoffrey de Havilland
 (1882-1965)

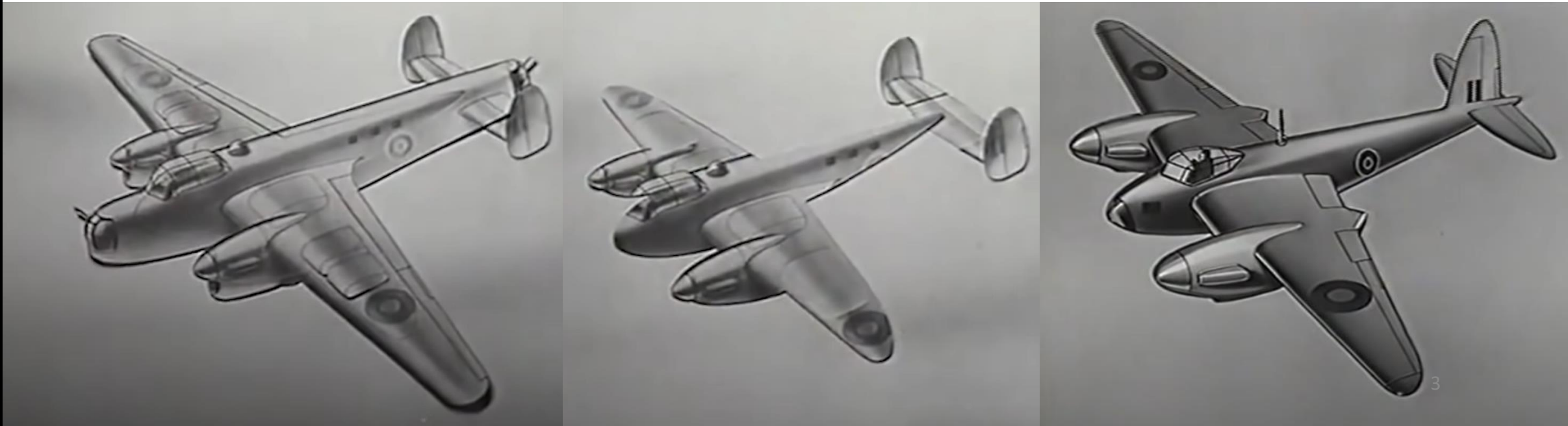

It's interesting to analyze the reasons why the Mosquito was built out of wood. Geoffrey de Havilland figured out that during the war, there would likely be a constant shortage of key metals (and other strategic materials) like aluminum and skilled metal workers, which were employed by the majority of aircraft companies. However, at the time, there was no shortage of wood, cabin makers, carpenters and woodworkers. Also, de Havilland was already working with wooden aircraft for decades, which reduced the risks and uncertainties of the manufacturing processes.

The fuselage is constructed of balsa wood planking, sandwiched between two plywood skins; the nose section is spruce plywood and the remainder birch, the whole forming a monocoque with interspaced bulkheads and formers. The oval cross section is tapered with cutaways to receive the wing and the cockpit canopy. It is made up in two halves, joined along the top and bottom center lines. The ingress and egress door, which may be jettisoned in case of emergency, is fitted on the starboard side of the fuselage forward of the wing cut-away. A hatch behind the wing on the starboard side, provides access to the rear of the fuselage. Access doors are provided on the upper nose portion, and side panels under the wing cut-away give access to the .303 in. and 20 mm. guns respectively. The outer skin is covered with madapolam.

The wing is a one-piece cantilever structure consisting of two wooden box spars extending over the full span, with stressed plywood skin covering, reinforced by spanwise spruce stringers. The wing is attached to the fuselage by four main bolts, and by additional bolts passing through the flanges of the inner ribs. Ten bullet-proof fuel tanks are housed within the wing and are accessible via detachable panels in the underside which form part of the stressed skin. The leading edges of the wing between the fuselage and the nacelles are made of aluminum alloy and form air intakes for the radiators located inside the wing. The outer leading edges are wooden with pressed plywood sheathing. Shields are located on the trailing edge, between the nacelles and the fuselage. The wing also houses landing lights, cables for electric and hoses for pneumatic and hydraulic systems and cables for the flight control system.

The wooden construction was glued together, which was well suited to Europe's cold climate. However, the Mosquito suffered several catastrophic crashes in the Far East theater. At first, these were thought to be a result of wing-structure failures. The casein glue, it was said, cracked when exposed to extreme heat and/or monsoon conditions. This caused the upper surfaces to "lift" from the main spar. It was found that "the accidents were not caused by the deterioration of the glue, but by shrinkage of the airframe during the wet monsoon season". However, a later inquiry by Cabot & Myers firmly attributed the accidents to faulty manufacture and this was confirmed by a further investigation team by the Ministry of Aircraft Production at Defford, which found faults in six Mosquito marks (all built at de Havilland's Hatfield and Leavesden plants). The defects were similar, and none of the aircraft had been exposed to monsoon conditions or termite attack.

The investigators concluded that construction defects occurred at the two plants. They found that the "standard of glueing left much to be desired." Records at the time showed that accidents caused by "loss of control" were three times more frequent on Mosquitos than on any other type of aircraft. The Air Ministry forestalled any loss of confidence in the Mosquito by holding to Major de Havilland's initial investigation in India that the accidents were caused "largely by climate" To solve the problem of seepage into the interior, a strip of plywood was set along the span of the wing to seal the entire length of the skin joint.

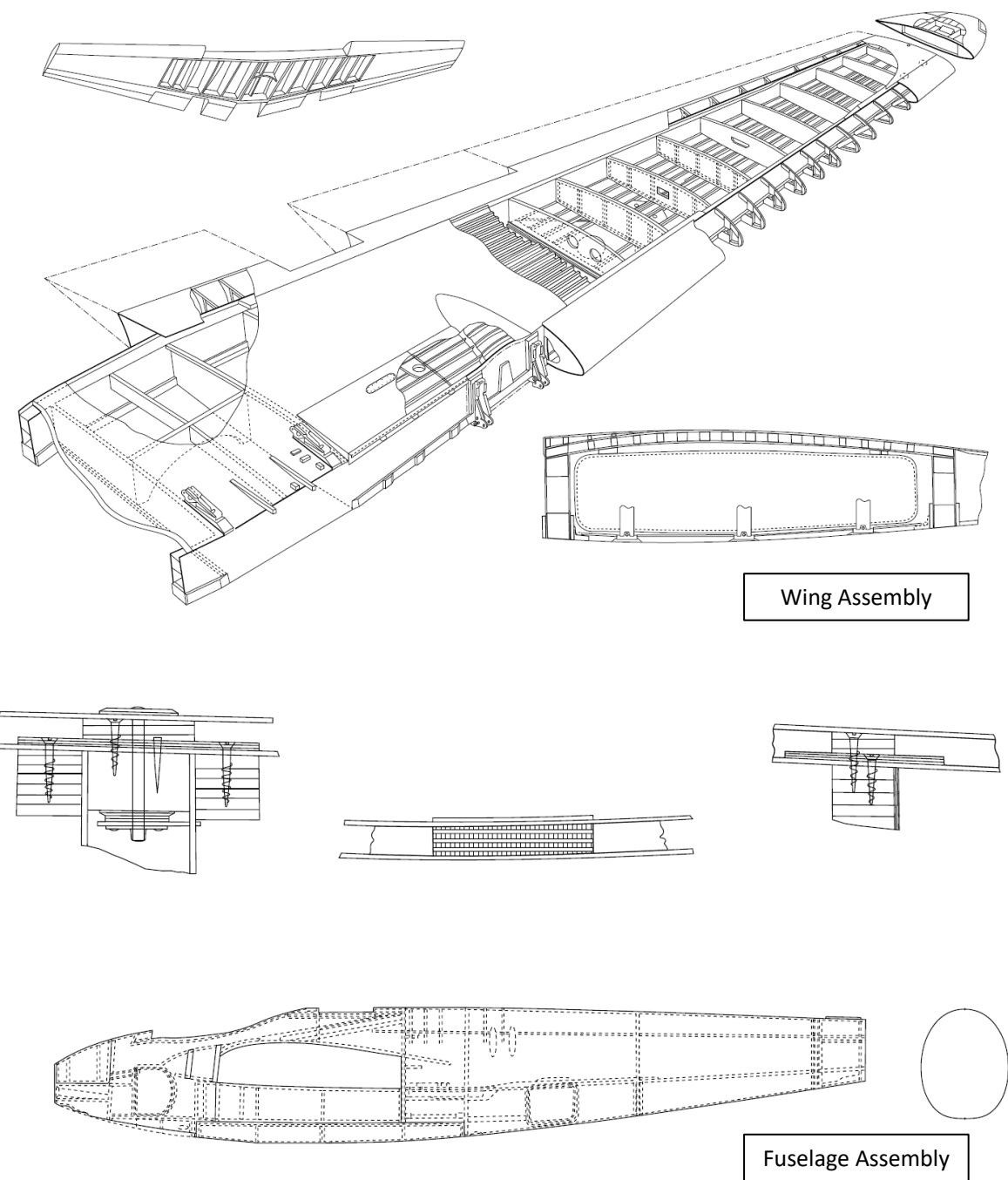



**DH.98 MOSQUITO
FB MK VI**

PART 1 – INTRODUCTION

The Mosquito excelled in every role the war planners threw at it. These kept on growing to meet the ever-changing demands of battle. Having proved its worth in photo-reconnaissance, the Mossie was next employed as a night-fighter. Using its integral Airborne Intercept 'AI' and ground-based radar systems, it shot down an estimated 600 enemy aircraft in this role alone. As the aircraft's performance improved, with increasingly uprated Merlin engines and tweaks to its construction, the Mossie was able to deliver a single, 4,000 lb 'Highball' bomb on high-value targets. By 1944, it could also be fitted with racks to mount 60 lb 'RP' rocket projectiles.

The Mosquito was first announced publicly on 26 September 1942 after the Oslo Mosquito raid of 25 September. It was featured in The Times on 28 September and the next day the newspaper published two captioned photographs illustrating the bomb strikes and damage. On 6 December 1942, Mosquitos from Nos. 105 and 139 Squadrons made up part of the bomber force used in Operation Oyster, the large No. 2 Group raid against the Philips works at Eindhoven.

From mid-1942 to mid-1943, Mosquito bombers flew high-speed, medium and low-altitude daylight missions against factories, railways and other pinpoint targets in Germany and German-occupied Europe. From June 1943, Mosquito bombers were formed into the Light Night Striking Force to guide RAF Bomber Command heavy bomber raids and as "nuisance" bombers, dropping Blockbuster bombs – 4,000 lb "cookies" – in high-altitude, high-speed raids that German night fighters were almost powerless to intercept. As a night fighter from mid-1942, the Mosquito intercepted Luftwaffe raids on Britain, notably those of Operation Steinbock in 1944. Starting in July 1942, Mosquito night-fighter units raided Luftwaffe airfields. As part of 100 Group, it was flown as a night fighter and as an intruder supporting Bomber Command heavy bombers that reduced losses during 1944 and 1945.

The Mosquito fighter-bomber served as a strike aircraft in the Second Tactical Air Force (2TAF) from its inception on 1 June 1943. The main objective was to prepare for the invasion of occupied Europe a year later. In Operation Overlord three Mosquito FB VI wings flew close air support for the Allied armies in co-operation with other RAF units equipped with the North American B-25 Mitchell medium bomber. In the months between the foundation of 2TAF and its duties from D day onwards, vital training was interspersed with attacks on V1 flying bomb launch sites. Interestingly, the Mosquito was so fast that it was also tasked with intercepting V1 rockets in flight and destroying them, which they did quite successfully. Intercepting the V1 was notoriously dangerous: machine gun bullets had little or no effect on its steel skin. Cannon shells, when they struck, could ignite the warhead, destroying the intercepting aircraft as well as the prey. Another and not much less dangerous tactic was to make a long turning dive on the V1 to get ahead of it. You could then use the Mosquito's propellor wash to destabilize the buzz bomb's gyro systems and topple it.

In another example of the daylight precision raids carried out by the Mosquitos of No. 105 and No. 139 Squadron, on 30 January 1943, the 10th anniversary of the Nazis' seizure of power, a morning Mosquito attack knocked out the main Berlin broadcasting station while Luftwaffe Chief Reichsmarschall Hermann Göring was speaking, putting his speech off the air. A second sortie in the afternoon inconvenienced another speech, by Propaganda Minister Joseph Goebbels.



One of the best examples of Mossie’s extraordinary capabilities was Operation Jericho (Ramrod 564), which took place on 18 February 1944. The mission was to free Allied prisoners facing execution from the Amiens prison by blasting holes in the prison walls with bombs. Coming at low altitude, Mosquito fighter-bombers lead by Group Captain Percy “Pick” Pickard breached the walls, prison buildings and destroyed the guards' barracks. Of the 832 prisoners, 102 were killed by the bombing, 74 were wounded and 258 escaped, including 79 Resistance and political prisoners; two-thirds of the escapees were recaptured. Two Mosquitos (including the one flown by Group Captain Pickard, who did not survive the crash) and a Typhoon fighter escort were shot down and another Typhoon was lost at sea. The raid is notable for the precision and daring of the attack, which was filmed by a camera on one of the Mosquitos. There is still debate to this day as to who requested the attack and whether it was necessary or not. Fun fact: you can fly this mission in the Channel map!

Interestingly, Pickard appeared as Squadron Leader Dickson in the famous RAF propaganda film “[Target for Tonight](#)”, released in July 1941. The plot concerned a Wellington bomber, F for Freddie taking part in a night time raid over Germany which is damaged during its return flight to England. Pickard was initially reluctant to appear. The film was produced by the Royal Air Force Film Production Unit and directed by Harry Watt. It was seen as a way to encourage people to join the service. It was a box office hit and won an Academy Award in 1942. Watt later expressed regret that most of the people featured in the film did not survive the war.

You can look at footage of Operation Jericho in the 1944 movie “Jail Breakers”: <https://youtu.be/GI2AxVJblg>



Group Captain Percy Charles “Pick” Pickard



Operation Jericho





DH.98 MOSQUITO
FB MK VI

PART 1 – INTRODUCTION

The greatest Mosquito ace of WW2 was Wing Commander Bransome Arthur "Branse" Burbridge, DSO and bar, DFC and bar, who with the outstanding help of his navigator Squadron Leader Bill Skelton had 21 confirmed victories.

While the Mk VI could not routinely overmatch the Fw-190 or the Me-109 in a straight dogfight, in the right hands it had the speed, firepower and maneuverability to hold its own against these types. Which as any WW2 Spitfire or Hurricane pilot would have told you, is no mean feat. To give one example: on 15 January 1945, 30 Fw.190s from Jagdgeschwader 5 pounced on No. 143 Squadron operating Mk VIs in the anti-shipping role. In the ensuing mêlée, No. 143 Squadron pilots shot down five Fw.190s while losing five of their own number (two of them reportedly to flak). But in the same engagement, the Mossies sank two German merchant ships and an armed trawler.

In the right hands, the Mosquito could be quite deadly. However, the types of missions it could do were often risky. Night missions were among the most dangerous. Pilots could get lost over enemy territory, collide with ground clutter when flying at low level, be attacked by "flak" anti-air artillery, blinded by spotlights, be bounced by night fighters... Germans even used decoy gliders with their navigation lights on to lure Mosquito pilots into "kill boxes" near their airfields.

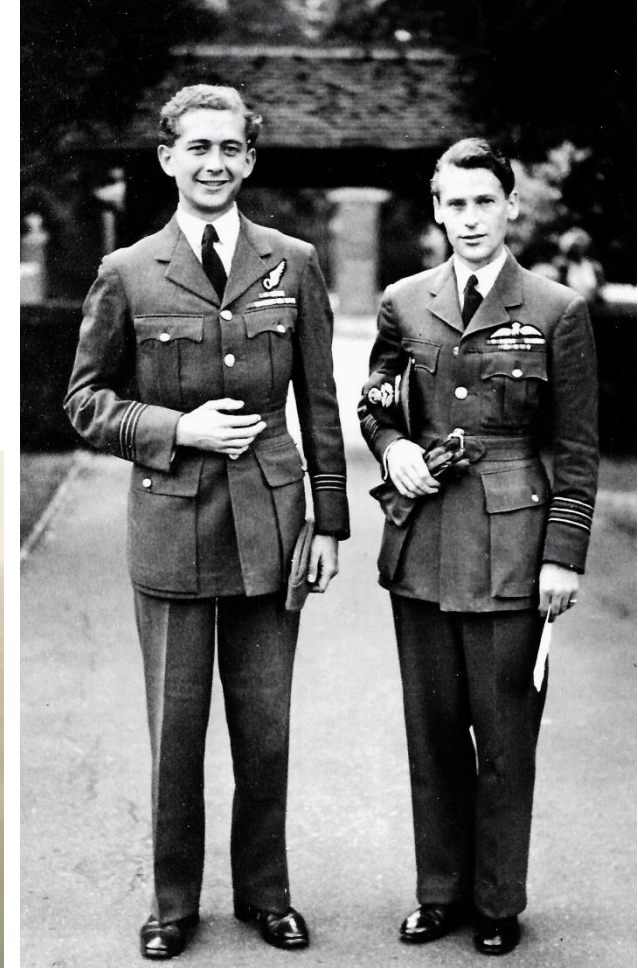
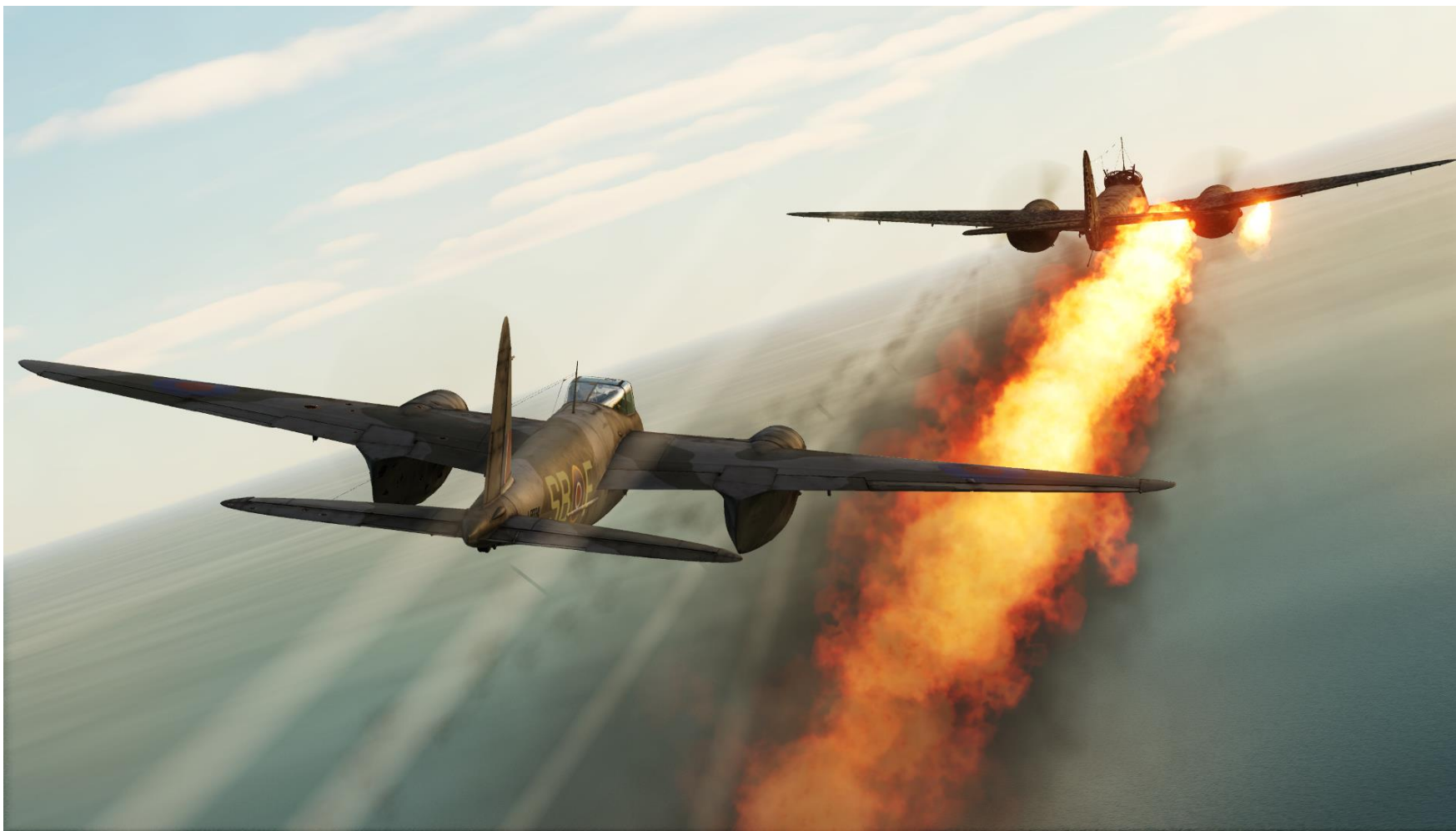

Navigator Squadron Leader Bill Skelton (Left)
Pilot Wing Commander "Branse" Burbridge (Right)



The Mosquito is an aircraft with plenty of interesting, outlandish stories.

Between 1943 and the end of the war, Mosquitos were used as transport aircraft on a regular route over the North Sea between Leuchars in Scotland and Stockholm. Lockheed Hudsons and Lodestars were also used but these slower aircraft could only fly this route at night or in bad weather to avoid the risk of being shot down. During the long daylight hours of the Northern summer, the Mosquito was the only safe alternative.

Because Sweden was neutral, the aircraft carried civilian markings and were operated by crews who were nominally "civilian employees" of BOAC (British Overseas Airways Corporation). They carried small, high value cargoes such as precision ball bearings and machine-tool steel. Occasionally, important passengers were carried in an improvised cabin in the bomb bay. One notable passenger was the physicist Niels Bohr. Niels left Denmark in the dramatic day and night (October 1943) when most Jews were able to escape to Sweden due to a series of very exceptional circumstances, The Allies used this event to try to recruit foreign scientists to join the war effort. Bohr was quickly offered to join the British. and he was flown to the UK for that purpose. The flight almost ended in tragedy as Bohr did not don his oxygen equipment as instructed, and passed out. He would have died had not the pilot, surmising from Bohr's lack of response to intercom communication that he had lost consciousness, descended to a lower altitude for the remainder of the flight. Bohr's comment was that he had slept like a baby for the entire flight.



DH98 Mosquito G-AGFV (DZ411) Mk IV BOAC on 8th January 1943 (Source: 2021 BAE Systems)



Niels Bohr 8

Source: AB Lagrelius & Westphal



A total of 7,781 Mosquitos were built in 48 variants. The Mossie equipped 26 RAF squadrons and saw service all over the world. About 5,000 of the total of 7,781 Mosquitos built had major structural components fabricated from wood in High Wycombe, Buckinghamshire, England. Fuselages, wings and tailplanes were made at furniture companies such as Ronson, E. Gomme, Parker Knoll, Austinsuite and Styles & Mealing. Wing spars were made by J. B. Heath and Dancer & Hearne. Many of the other parts, including flaps, flap shrouds, fins, leading edge assemblies and bomb doors were also produced in the Buckinghamshire town. Dancer & Hearne processed much of the wood from start to finish, receiving timber and transforming it into finished wing spars at their factory in Penn Street on the outskirts of High Wycombe.

Initially, much of the specialized yellow birch wood veneer and finished plywood used for the prototypes and early production aircraft was shipped from firms in Wisconsin, US. Prominent in this role were Roddis Plywood and Veneer Manufacturing in Marshfield. In conjunction with the USDA Forest Products Laboratory, Hamilton Roddis had developed new plywood adhesives and hot pressing technology. Later on, paper birch was logged in large quantities from the interior of British Columbia along the Fraser and Quesnel Rivers and processed in Quesnel and New Westminster by the Pacific Veneer Company. According to the Quesnel archives, BC paper birch supplied half of the wartime British Empire birch used for Mosquitos and other aircraft.

In July 1941, it was decided that DH Canada would build Mosquitos at Downsview, Ontario. This was to continue even if Germany invaded Great Britain. Many of the workers on the aircraft assembly lines were women. Packard Merlin engines produced under license were bench-tested by August and the first two aircraft were built in September. Production was to increase to fifty per month by early 1942. Initially, the Canadian production was for bomber variants; later, fighters, fighter-bombers and training aircraft were also made. De Havilland Canada assembled 1,032 Mosquitos in Toronto, and de Havilland Australia constructed another 1,032 from 1943 to 1945.





The Mosquito even had its cinematic rise to fame when the 1964 British war film "633 Squadron" came out. The movie was directed by Walter Grauman and starred Cliff Robertson, George Chakiris, and Maria Perschy. The musical score is something that is hard to forget.

Overall, flying the Mossie in DCS is a thrilling experience. Flying it with a friend in multiplayer is the best way to combine the stressful job of flying at treetop level while having someone else giving you steering cues, checking for bandits and managing the fuel tanks and radios at the back. In the kinds of missions the FB VI is good at (low level attacks), dodging trees and power lines requires such concentration from the pilot that it makes the role of a navigator all the more essential.

You will be flying one hell of a quirky airplane. Failing to properly manage engine torque on takeoff can have disastrous consequences. Losing an engine in flight can be more or less difficult to handle based on whether you were able to successfully feather the propeller blade or not. Operating the T1154/R1155 radio set while gazing at the "magic eye" can feel a bit like performing witchcraft. All of this is part of the Mosquito's charm. Once the guns start firing... I can't help but have that smug, satisfied grin on my face.

To me, the "Wooden Wonder" is more than a relic of a long gone era of aviation. It's part of a shift in mentality towards the necessity for modern multirole aircraft. It is an aircraft that defied conventions and brought wild, creative ideas to the table. Despite its small size, it could rival the "heavies" like the B-17 and the Lancaster in terms of bomb payload. A crew of two could do the job of a crew of eight, which highlights the need for a good crew to work together. This says a lot about the quality of the plane.

I hope you enjoy flying this plane as much as I do. The roar of those Merlins are a real trip back through time.



WHAT YOU NEED MAPPED

Trigger Button (Release Bomb/Guncam)
(SHIFT+SPACE)
(hidden grey button on right hand side)

Fire Cannons
(RALT+SPACE)

Fire Machineguns
(SPACE)

↑ Shoulder Harness (Release/Lock)
→ Wheel Brake Lock
←
↑
P

Wing Fuel Tank Jettison Button - Press

Wheel Brakes Lever



↑ Trim Elevator DOWN
→ Trim Rudder RIGHT
↓ Trim Elevator UP
← Trim Rudder LEFT

↑ Zoom In Slow
→
↓ Zoom Out Slow
←

Fire Rockets Trigger Button (LALT+SPACE)
(red button in front of throttle)

Engine (Selected) RPM

Supercharger – Cycle
Mode (MOD/AUTO)

↑
→ COMM – Push-to-Talk
↓
←
P

Throttle Lever
(Selected)

← Flaps Push DOWN
→ Flaps Pull UP

T1154 Key Button - Press

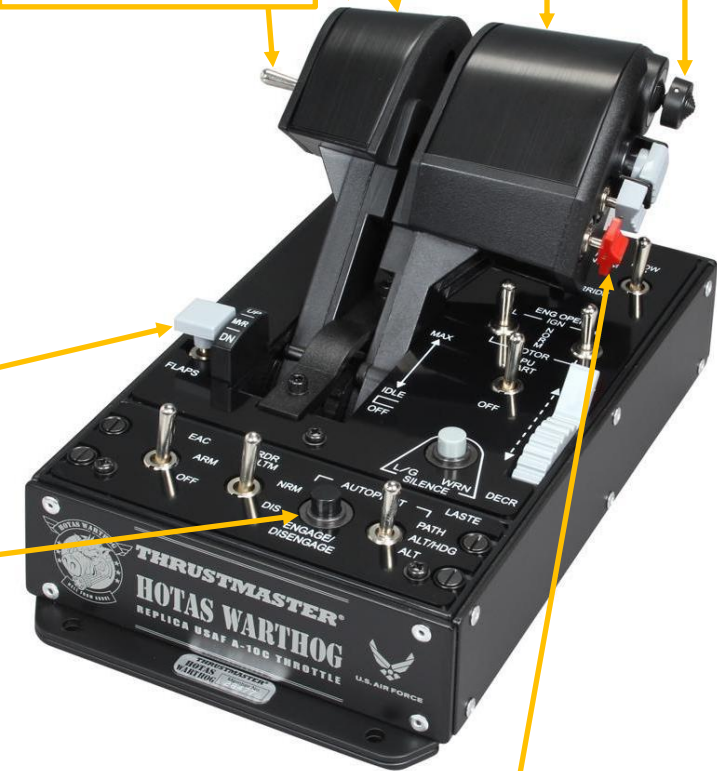

← Undercarriage Gear Lever – Push DOWN
→ Undercarriage Gear Lever – Pull UP

OPTIONS

SYSTEM **CONTROLS** GAMEPLAY MISC. AUDIO SPECIAL VR

Spitfire LF Mk IX Sim Axis Commands Foldable view Reset category to default Clear category Clear all Load profile Save profile as

Action	Category	Keyboard	Throttle - HOTAS...	Saitek Pro Flight ...	Joystick - HOTAS ...	TI
Camera Horizontal View						
Camera Roll View						
Camera Vertical View						
Camera Zoom View						
Compass Course (analog)	Front Dash					
Engine RPM (analog)	Engine Controls			JOY_RZ		
Gun Sight Base (analog)	Gun Sight					
Gun Sight Illumination (analog)	Gun Sight					
Gun Sight Range (analog)	Gun Sight					
Head Tracker : Forward/Backward						
Head Tracker : Pitch						
Head Tracker : Right/Left						
Head Tracker : Roll						
Head Tracker : Up/Down						
Head Tracker : Yaw						TI
LH Dashboard Lamp Brightness (analog)	Cockpit Illumination					
Pitch						JOY_Y
RH Dashboard Lamp Brightness (analog)	Cockpit Illumination					
Roll						JOY_X
Rudder				JOY_RZ		
TDC Slew Horizontal (mouse)						
TDC Slew Vertical (mouse)						
Throttle (analog)	Engine Controls			JOY_Z		
Trim Elevator (analog)	Flight Control					

Modifiers Add Clear Default **Axis Assign** **Axis Tune** FF Tune Make HTML Disable hot plug Rescan devices

CANCEL OK

To assign axis, click on "Axis Assign". You can also select "Axis Commands" in the upper scrolling menu.

To modify curves and sensitivities of axes, click on the axis you want to modify and then click "Axis Tune".

Bind the following axes:

- Pitch (Deadzone at 0, Saturation X at 100, Saturation Y at 100, Curvature at 30)
- Roll (Deadzone at 0, Saturation X at 100, Saturation Y at 100, Curvature at 0)
- Rudder (Deadzone at 3, Saturation X at 100, Saturation Y at 100, Curvature at 0)
- Engine (Selected) RPM / Propeller Pitch – Controls RPM
- Throttle Engine (Selected) – Controls Manifold Pressure / Boost

OPTIONS ✕

SYSTEM	CONTROLS	GAMEPLAY	MISC.	AUDIO	SPECIAL	VR
Mosquito FB Mk. VI	Axis Commands	<input type="checkbox"/> Foldable view	Reset category to default	Clear category	Clear all	Load profile Save profile as
Action	Category	Keyboard	Throttle - HOTAS...	Saitek Pro Flight ...	Joystick - HOTAS ...	Tr
Mixture - axis	Engine Controls					
Pitch					JOY_Y	
Prop pitch lever friction - axis	Engine Controls					
R1155, loop antenna rotate - axis	T.1154/R.1155 Radio Set,					
R1155, meter amplitude knob - axis	T.1154/R.1155 Radio Set,					
R1155, meter balance knob - axis	T.1154/R.1155 Radio Set,					
R1155, volume - axis	T.1154/R.1155 Radio Set,					
Repeater Compass Course - axis	Front Dash					
Right Instrument Light - axis	Environment System, Elec					
Roll					JOY_X	
Rudder					JOY_RZ	
SCR522, volume - axis	SCR-522 Radio Set, Comr					
T1154, master oscillator C2 vernier - axis	T.1154/R.1155 Radio Set,					
T1154, master oscillator C4 vernier - axis	T.1154/R.1155 Radio Set,					
T1154, master oscillator tuning capacitor C17 - axis	T.1154/R.1155 Radio Set,					
T1154, master oscillator tuning capacitor C2 - axis	T.1154/R.1155 Radio Set,					
T1154, master oscillator tuning capacitor C4 - axis	T.1154/R.1155 Radio Set,					
T1154, output inductance control L6 - axis	T.1154/R.1155 Radio Set,					
T1154, output tuning capacitor C15 - axis	T.1154/R.1155 Radio Set,					
T1154, output tuning capacitor C16 - axis	T.1154/R.1155 Radio Set,					
TDC Slew Horizontal (mouse)						
TDC Slew Vertical (mouse)						
Throttle Friction - axis	Engine Controls					
Throttle, engine (selected) - axis	Engine Controls			JOY_Z		

Modifiers Add Clear Default Axis Assign Axis Tune FF Tune Make HTML Disable hot plug Rescan devices

CANCEL
OK



In the “Special” menu in Options, select the Mosquito FB Mk VI menu. Make sure to have Takeoff Assist set to “0” (turned off). By default it is set to 100 (ON). Also make sure to uncheck the Auto-Rudder box. Here my recommendations for other special options, but they are merely suggestions; feel free to use any other setting for your own needs and preferences.

OPTIONS

SYSTEM CONTROLS GAMEPLAY MISC. AUDIO **SPECIAL** VR

MiG-19P

Mosquito FB Mk. VI

NS430

P-47D-30

P-51D

SA342

Spitfire LF Mk. IX

Su-25T

TF-51D

UH-1H

Yak-52

Tacview

DCS-SRS

DH.98 Mosquito FB Mk. VI

TAKE-OFF ASSISTANCE 0

THROTTLE DETENT Automatically jump over

Auto Rudder Automatically compensate for side slip in flight

COCKPIT CAMERA ORIGIN Shift to aim when shoulder harness is released

Customized Cockpit Default

CANCEL OK

Set Takeoff Assist to “0”

Set Throttle Detent to Automatically Jump Over

Set Auto-Rudder to OFF (Uncheck Box)

Set Cockpit Camera Origin – Shift to aim when Shoulder Harness is released



DH.98 MOSQUITO
FB MK VI

PART 3 - COCKPIT & EQUIPMENT





DH.98 MOSQUITO
FB MK VI

PART 3 – COCKPIT & EQUIPMENT

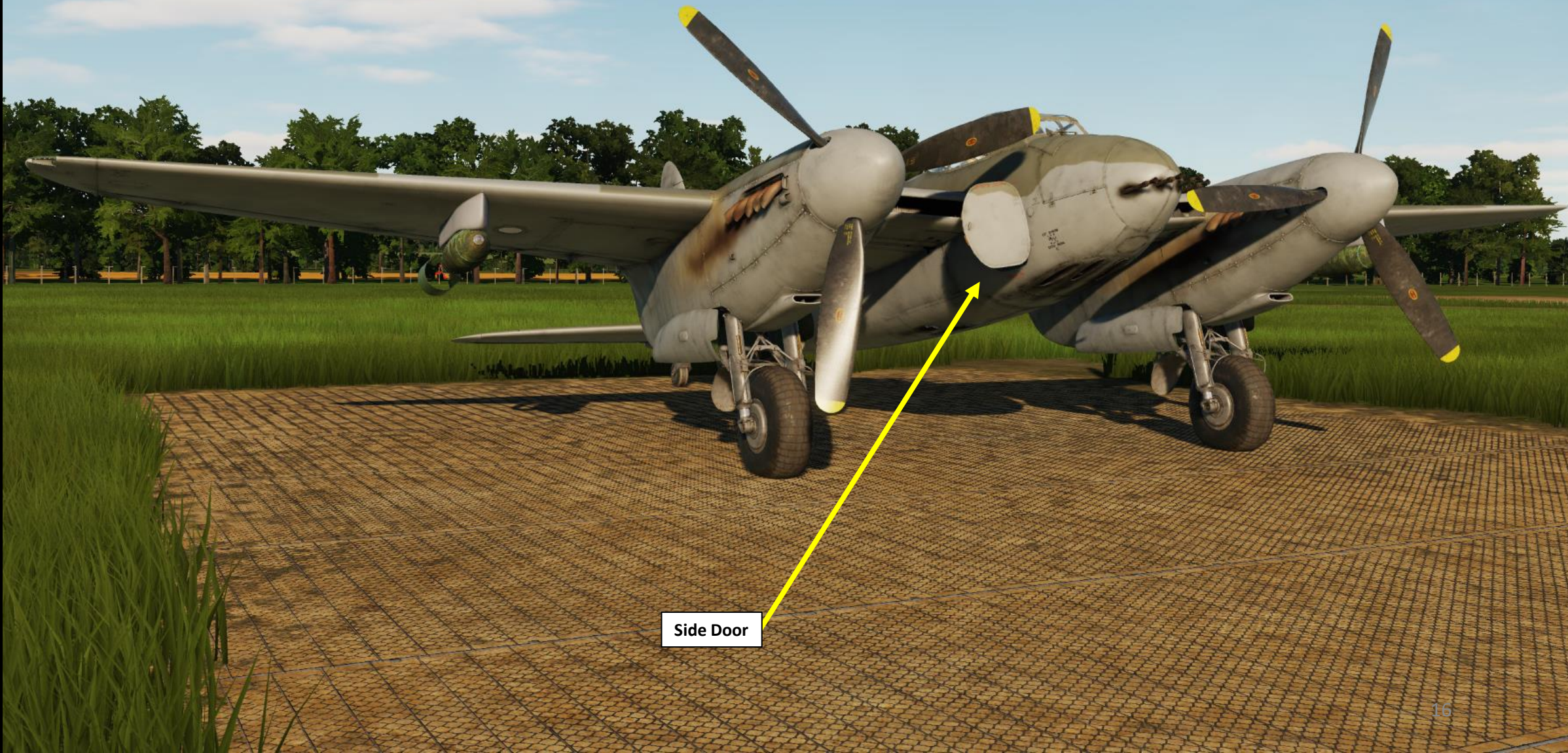

Side Door



Mosquito II Fighter Variant

Image from *Classic World War II Aircraft Cutaways*, by Bill Guston in association with *The Aeroplane and Flight* magazines.

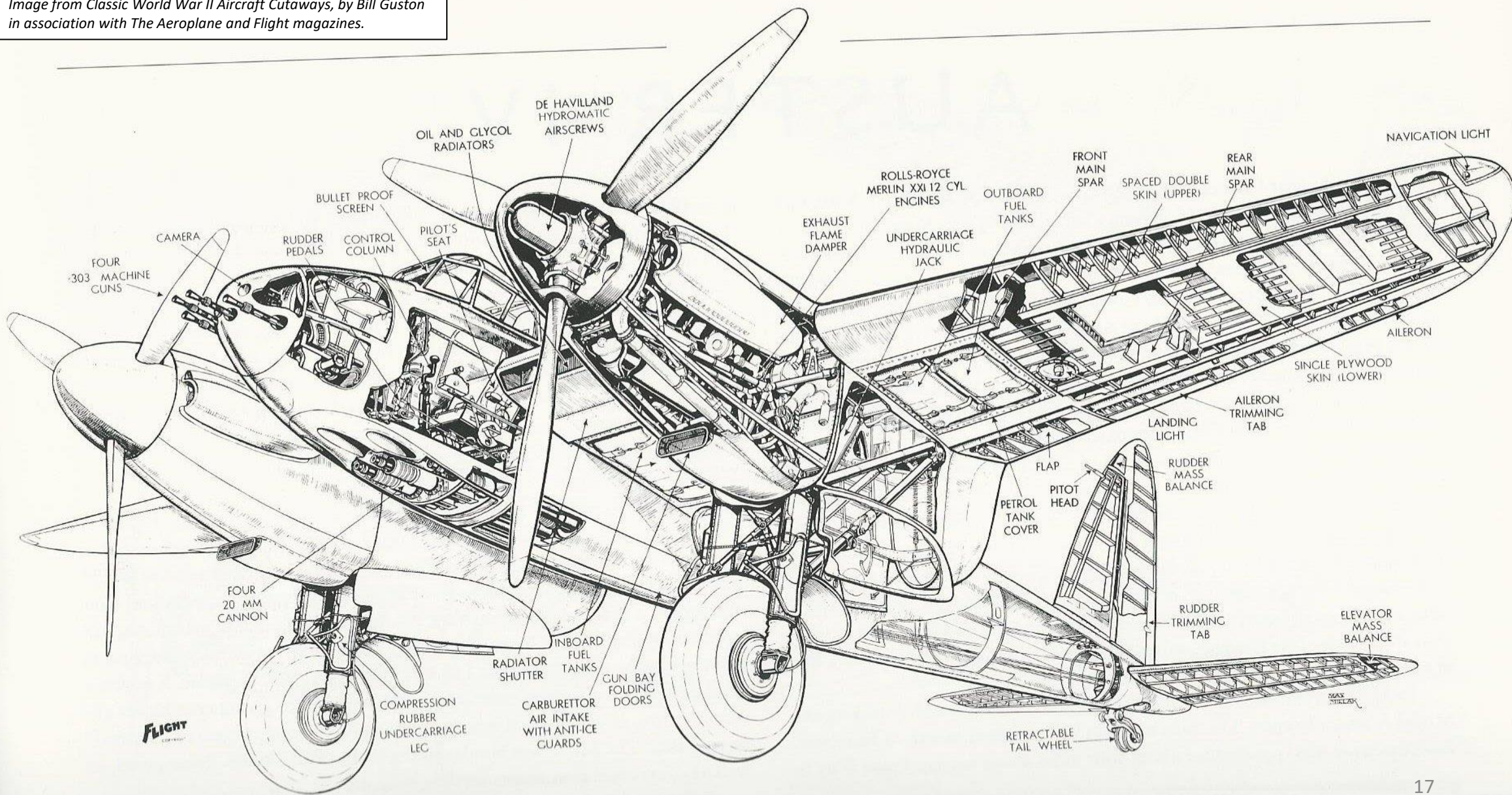

FLIGHT



De Havilland Mosquito B Mk IV Bomber Variant

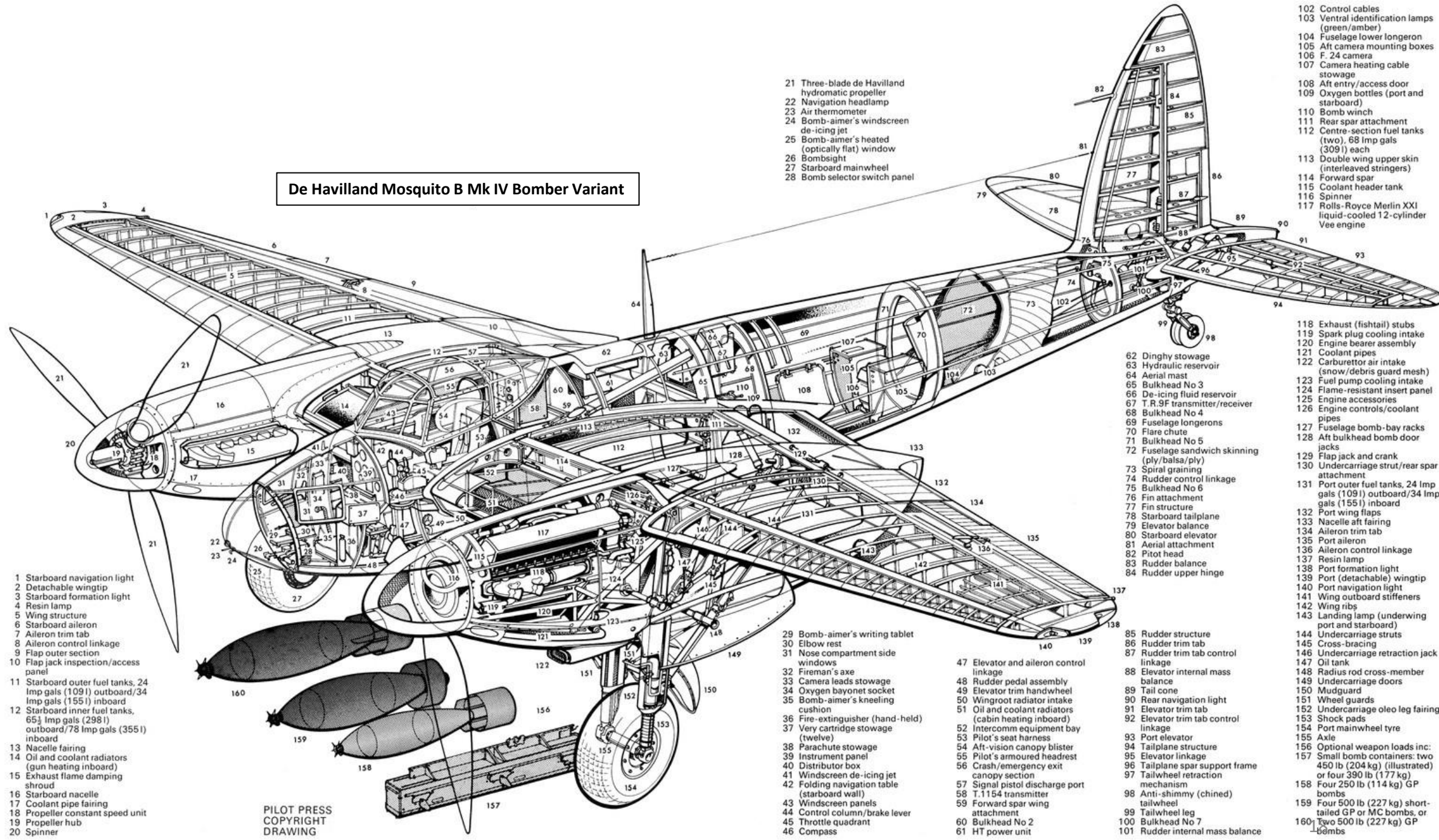

- 1 Starboard navigation light
- 2 Detachable wingtip
- 3 Starboard formation light
- 4 Resin lamp
- 5 Wing structure
- 6 Starboard aileron
- 7 Aileron trim tab
- 8 Aileron control linkage
- 9 Flap outer section
- 10 Flap jack inspection/access panel
- 11 Starboard outer fuel tanks, 24 Imp gals (109 l) outboard/34 Imp gals (155 l) inboard
- 12 Starboard inner fuel tanks, 65 1/2 Imp gals (298 l) outboard/78 Imp gals (355 l) inboard
- 13 Nacelle fairing
- 14 Oil and coolant radiators (gun heating inboard)
- 15 Exhaust flame damping shroud
- 16 Starboard nacelle
- 17 Coolant pipe fairing
- 18 Propeller constant speed unit
- 19 Propeller hub
- 20 Spinner

PILOT PRESS
COPYRIGHT
DRAWING

- 21 Three-blade de Havilland hydromatic propeller
- 22 Navigation headlamp
- 23 Air thermometer
- 24 Bomb-aimer's windscreens de-icing jet
- 25 Bomb-aimer's heated (optically flat) window
- 26 Bombsight
- 27 Starboard mainwheel
- 28 Bomb selector switch panel

- 29 Bomb-aimer's writing tablet
- 30 Elbow rest
- 31 Nose compartment side windows
- 32 Fireman's axe
- 33 Camera leads stowage
- 34 Oxygen bayonet socket
- 35 Bomb-aimer's kneeling cushion
- 36 Fire-extinguisher (hand-held)
- 37 Very cartridge stowage (twelve)
- 38 Parachute stowage
- 39 Instrument panel
- 40 Distributor box
- 41 Windscreens de-icing jet
- 42 Folding navigation table (starboard wall)
- 43 Windscreens panels
- 44 Control column/brake lever
- 45 Throttle quadrant
- 46 Compass

- 47 Elevator and aileron control linkage
- 48 Rudder pedal assembly
- 49 Elevator trim handwheel
- 50 Wingroot radiator intake
- 51 Oil and coolant radiators (cabin heating inboard)
- 52 Intercomm equipment bay
- 53 Pilot's seat harness
- 54 Aft-vision canopy blister
- 55 Pilot's armoured headrest
- 56 Crash/emergency exit canopy section
- 57 Signal pistol discharge port
- 58 T.1154 transmitter
- 59 Forward spar wing attachment
- 60 Bulkhead No 2
- 61 HT power unit

- 62 Dinghy stowage
- 63 Hydraulic reservoir
- 64 Aerial mast
- 65 Bulkhead No 3
- 66 De-icing fluid reservoir
- 67 T. R. 9F transmitter/receiver
- 68 Bulkhead No 4
- 69 Fuselage longerons
- 70 Flare chute
- 71 Bulkhead No 5
- 72 Fuselage sandwich skinning (ply/balsa/ply)
- 73 Spiral graining
- 74 Rudder control linkage
- 75 Bulkhead No 6
- 76 Fin attachment
- 77 Fin structure
- 78 Starboard tailplane
- 79 Elevator balance
- 80 Starboard elevator
- 81 Aerial attachment
- 82 Pitot head
- 83 Rudder balance
- 84 Rudder upper hinge

- 85 Rudder structure
- 86 Rudder trim tab
- 87 Rudder trim tab control linkage
- 88 Elevator internal mass balance
- 89 Tail cone
- 90 Rear navigation light
- 91 Elevator trim tab
- 92 Elevator trim tab control linkage
- 93 Port elevator
- 94 Tailplane structure
- 95 Elevator linkage
- 96 Tailplane spar support frame
- 97 Tailwheel retraction mechanism
- 98 Anti-shimmy (chined) tailwheel
- 99 Tailwheel leg
- 100 Bulkhead No 7
- 101 Rudder internal mass balance

- 102 Control cables
- 103 Ventral identification lamps (green/amber)
- 104 Fuselage lower longeron
- 105 Aft camera mounting boxes
- 106 F. 24 camera
- 107 Camera heating cable stowage
- 108 Aft entry/access door
- 109 Oxygen bottles (port and starboard)
- 110 Bomb winch
- 111 Rear spar attachment
- 112 Centre-section fuel tanks (two), 68 Imp gals (309 l) each
- 113 Double wing upper skin (interleaved stringers)
- 114 Forward spar
- 115 Coolant header tank
- 116 Spinner
- 117 Rolls-Royce Merlin XXI liquid-cooled 12-cylinder Vee engine

- 118 Exhaust (fishtail) stubs
- 119 Spark plug cooling intake
- 120 Engine bearer assembly
- 121 Coolant pipes
- 122 Carburettor air intake (snow/debris guard mesh)
- 123 Fuel pump cooling intake
- 124 Flame-resistant insert panel
- 125 Engine accessories
- 126 Engine controls/coolant pipes
- 127 Fuselage bomb-bay racks
- 128 Aft bulkhead bomb door jacks
- 129 Flap jack and crank
- 130 Undercarriage strut/rear spar attachment
- 131 Port outer fuel tanks, 24 Imp gals (109 l) outboard/34 Imp gals (155 l) inboard
- 132 Port wing flaps
- 133 Nacelle aft fairing
- 134 Aileron trim tab
- 135 Port aileron
- 136 Aileron control linkage
- 137 Resin lamp
- 138 Port formation light
- 139 Port (detachable) wingtip
- 140 Port navigation light
- 141 Wing outboard stiffeners
- 142 Wing ribs
- 143 Landing lamp (underwing port and starboard)
- 144 Undercarriage struts
- 145 Cross-bracing
- 146 Undercarriage retraction jack
- 147 Oil tank
- 148 Radius rod cross-member balance
- 149 Undercarriage doors
- 150 Mudguard
- 151 Wheel guards
- 152 Undercarriage oleo leg fairing
- 153 Shock pads
- 154 Port mainwheel tyre
- 155 Axle
- 156 Optional weapon loads inc: Small bomb containers: two 450 lb (204 kg) (illustrated) or four 390 lb (177 kg)
- 157 Four 250 lb (114 kg) GP bombs
- 158 Four 500 lb (227 kg) short-tailed GP or MC bombs, or two 500 lb (227 kg) GP bombs
- 160



DH.98 MOSQUITO
FB MK VI

PART 3 – COCKPIT & EQUIPMENT

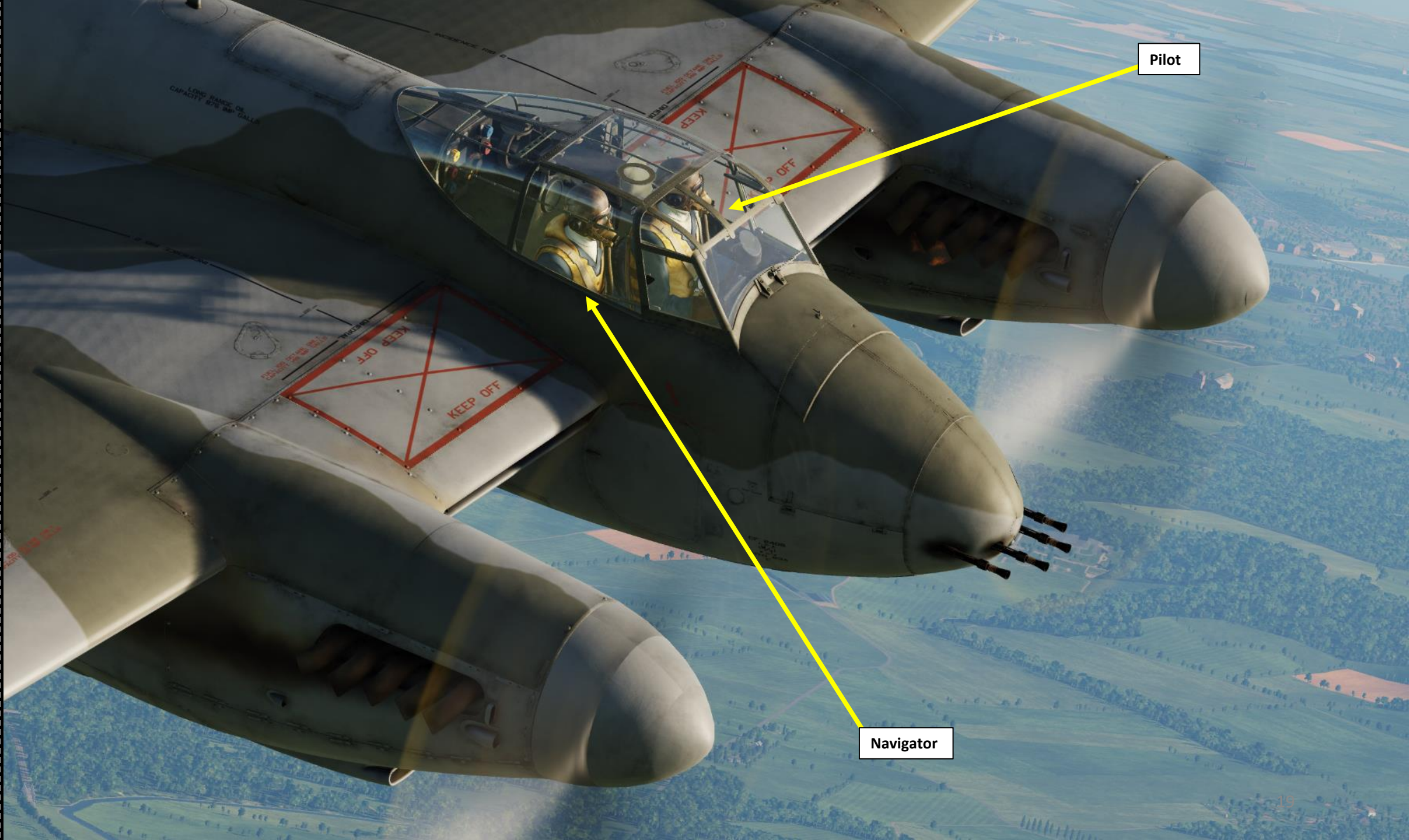

Pilot

Navigator



DH.98 MOSQUITO
FB MK VI

PART 3 - COCKPIT & EQUIPMENT





**Remote Indicating (R.I.)
Compass Power Switch**

- UP: OFF
- DOWN: ON

**Remote Indicating (R.I.) Compass Power
Switch**

- UP: OFF
- DOWN: ON

**Beam Approach A1271
Receiver Power Switch**

- UP: OFF
- DOWN: ON

**Radio Push-to-Talk
Button**

Armrest

**Elevator Trim
Control Wheel**



Left Window Lock



Undercarriage Emergency Placard

1. Hold Undercarriage Lever down for 20 seconds max.
2. Emergency knob down. Operate hand pump (up to 4 minutes)
3. Undercarriage lever down emergency knob up. Operate hand pump (up to 4 minutes) (flap lever must be neutral)
4. If no green lights, maintain pressure on hand pump during landing & taxiing.

Engine Data Plate

Automatic Supercharger Gear Change Switch Operates at 21000 ft

- For Maximum Combat Climb – AUTO
 - For Maximum Level Speed – MOD. Up to 23500 ft
- Merlin 113 & 114

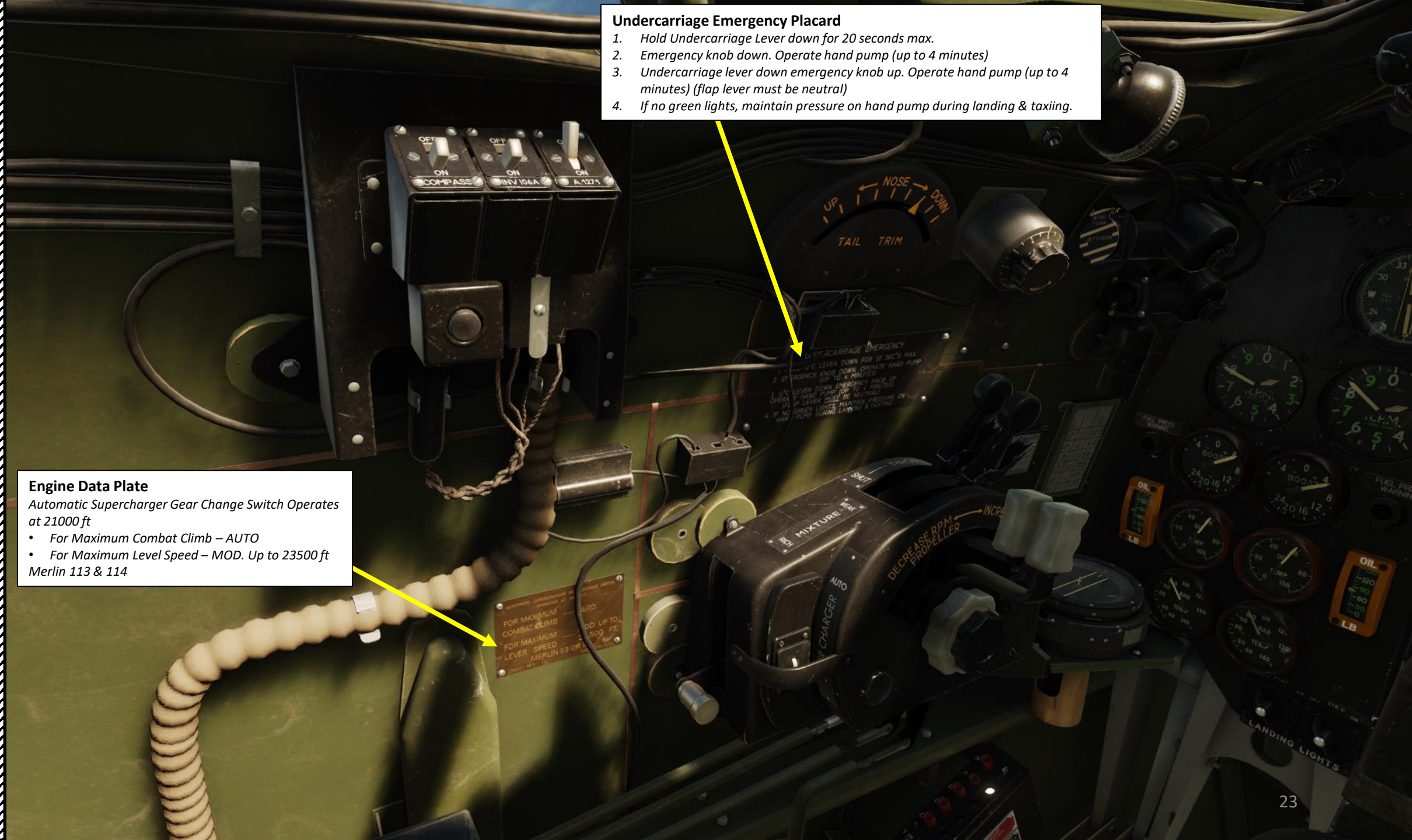



Seat Height
Adjustment Lever

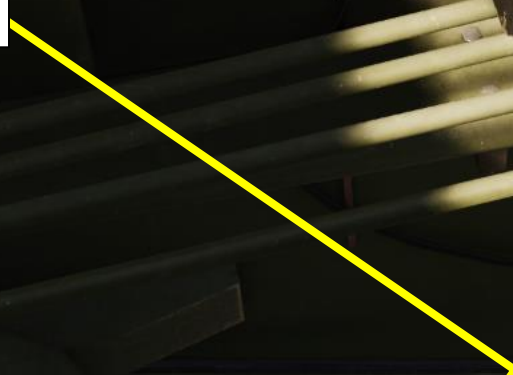

EMERGENCY
FOR 20 SEC'S MAX
OPERATE HAND PUMP
(UP TO 4 MINUTES)
EMERGENCY KNOB DOWN
3. U/C LEVER DOWN EMERGENCY KNOB UP
OPERATE HAND PUMP (UP TO 4 MINUTES)
(FLAP LEVER MUST BE NEUTRAL)
4. IF NO GREEN LIGHTS MAINTAIN PRESSURE ON
HAND PUMP DURING LANDING & TAXIING

FOR MAXIMUM
COMBAT CLIMB
FOR MAXIMUM
LEVER SPEED
MERLIN IS OP

RICH MIXTURE LEAN

DECREASE RPM
PROPELLER



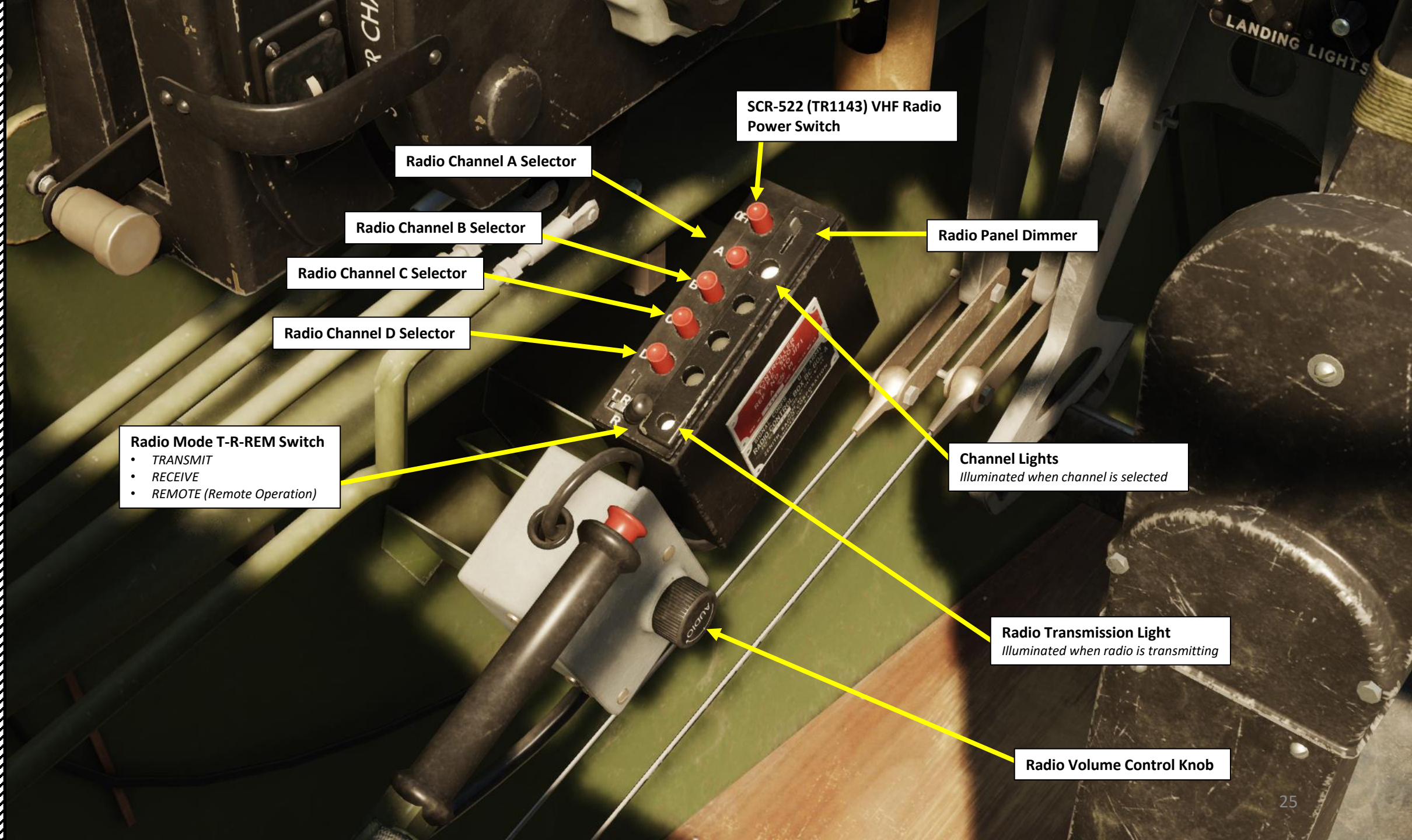

SCR-522 (TR1143) VHF Radio
Power Switch

Radio Channel A Selector

Radio Channel B Selector

Radio Channel C Selector

Radio Channel D Selector

Radio Panel Dimmer

Radio Mode T-R-REM Switch
• TRANSMIT
• RECEIVE
• REMOTE (Remote Operation)

Channel Lights
Illuminated when channel is selected

Radio Transmission Light
Illuminated when radio is transmitting

Radio Volume Control Knob

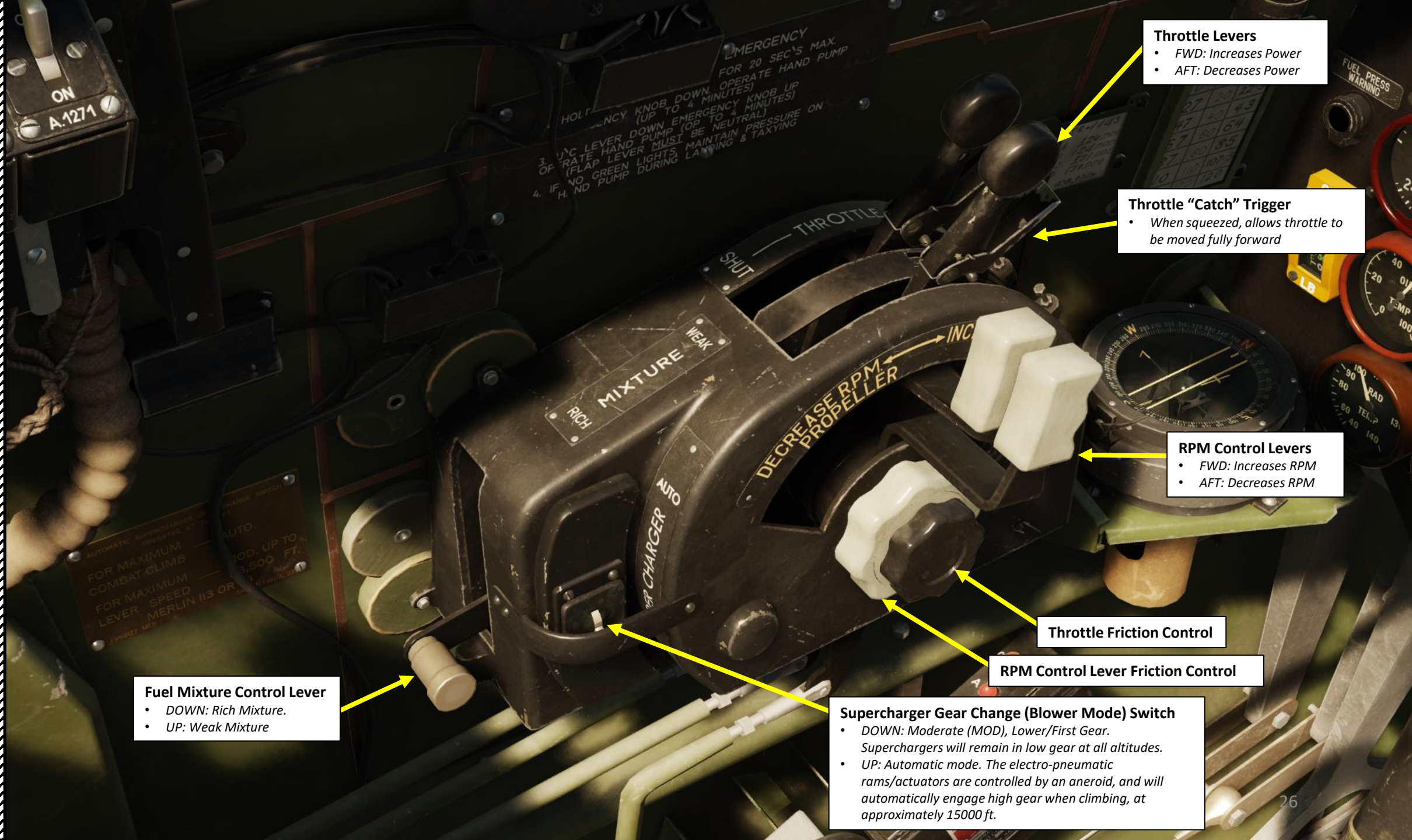

Throttle Levers

- FWD: Increases Power
- AFT: Decreases Power

Throttle "Catch" Trigger

- When squeezed, allows throttle to be moved fully forward

RPM Control Levers

- FWD: Increases RPM
- AFT: Decreases RPM

Throttle Friction Control

RPM Control Lever Friction Control

Fuel Mixture Control Lever

- DOWN: Rich Mixture.
- UP: Weak Mixture

Supercharger Gear Change (Blower Mode) Switch

- DOWN: Moderate (MOD), Lower/First Gear. Superchargers will remain in low gear at all altitudes.
- UP: Automatic mode. The electro-pneumatic rams/actuators are controlled by an aneroid, and will automatically engage high gear when climbing, at approximately 15000 ft.

EMERGENCY
FOR 20 SEC'S MAX.
(UP TO 4 MINUTES)
EMERGENCY KNOB DOWN, OPERATE HAND PUMP
(UP TO 4 MINUTES)
EMERGENCY KNOB UP
(UP TO 4 MINUTES)
EMERGENCY KNOB DOWN, OPERATE HAND PUMP
(UP TO 4 MINUTES)
EMERGENCY KNOB UP
(UP TO 4 MINUTES)
EMERGENCY KNOB DOWN, OPERATE HAND PUMP
(UP TO 4 MINUTES)
EMERGENCY KNOB UP
(UP TO 4 MINUTES)

ON
A.1271

FOR MAXIMUM
COMBAT CLIMB
FOR MAXIMUM
LEVER SPEED
MERLIN IIS OR
1500 FT.



Elevator Trim Control Tab Indicator

Cockpit UV (Ultraviolet) Light
Turn to adjust

External Wing Fuel Tank Jettison Button
Flip safety cover, then press button to jettison
external wing fuel tanks

Emergency Flood Light Dimmer
Turn to adjust

Left Instrument Light Dimmer
Turn to adjust

Compass Light Dimmer
Turn to adjust

UV Exciter Button

Beam Approach A1271
Receiver Volume Knob

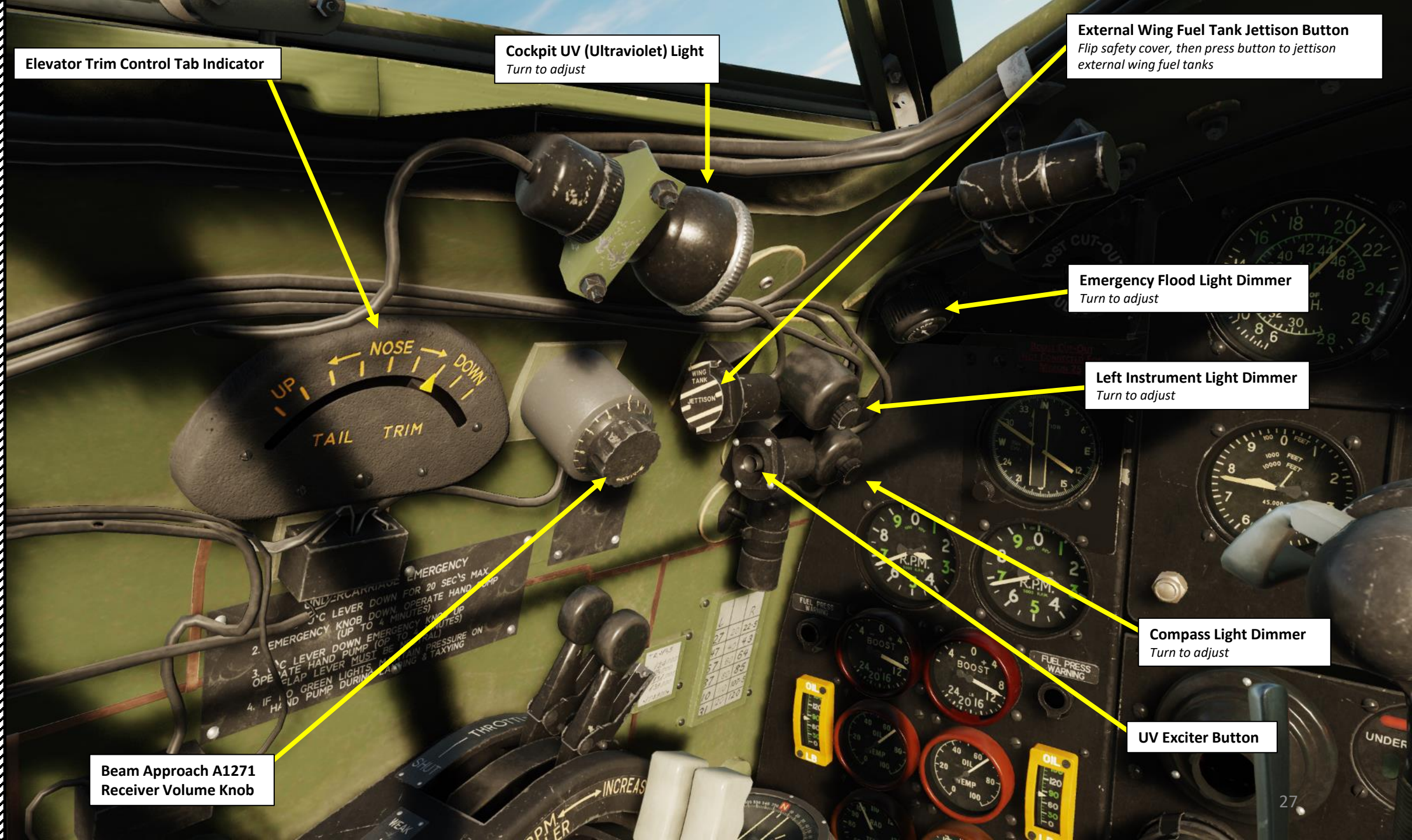

UNDERCARRIAGE EMERGENCY
UP LEVER DOWN FOR 20 SEC'S MAX.
EMERGENCY KNOB DOWN. OPERATE HAND PUMP
(UP TO 4 MINUTES)
EVER DOWN EMERGENCY KNOB UP
E HAND PUMP (OP TO 4 MINUTES)
AP LEVER MUST BE NEUTRAL)
GREEN LIGHTS. MAINTAIN PRESSURE ON
D PUMP DURING LANDING & TAXYING

SCR-522 (TR1143) Radio Channel
Frequencies Placard (MHz)

TR-1143
A 124.000
B 124.000
C 131.000
D 131.000
E 108.900

L		R
27	20	22.5
47	40	43
67	60	64
87	80	85
110	110	107.5
131	120	120

Direction Finder (D/F)
Deviation/Calibration Table Placard

This table shows the actual known bearing of the radio emitter vs what the D/F loop antenna scale is telling you the bearing is (center column). The LEFT and RIGHT columns of the table indicate whether the bearing of the radio source is to your left or to your right.

Left	Direction Finder Scale Reference Value	Right
27	20	22.5
47	40	43
67	60	64
87	80	85
110	110	107.5
131	120	120



P-8 Magnetic Compass



DH.98 MOSQUITO
FB MK VI

PART 3 - COCKPIT & EQUIPMENT



Shoulder Harness Release Lever

- UP: Harness Released
- DOWN: Harness Locked

First Aid Kit



Gunsight



Gunsight Range Control (x100 yards)

Gunsight Target Wingspan Control (ft)



Wiper

Gunsight Brightness
Intensity Control Knob

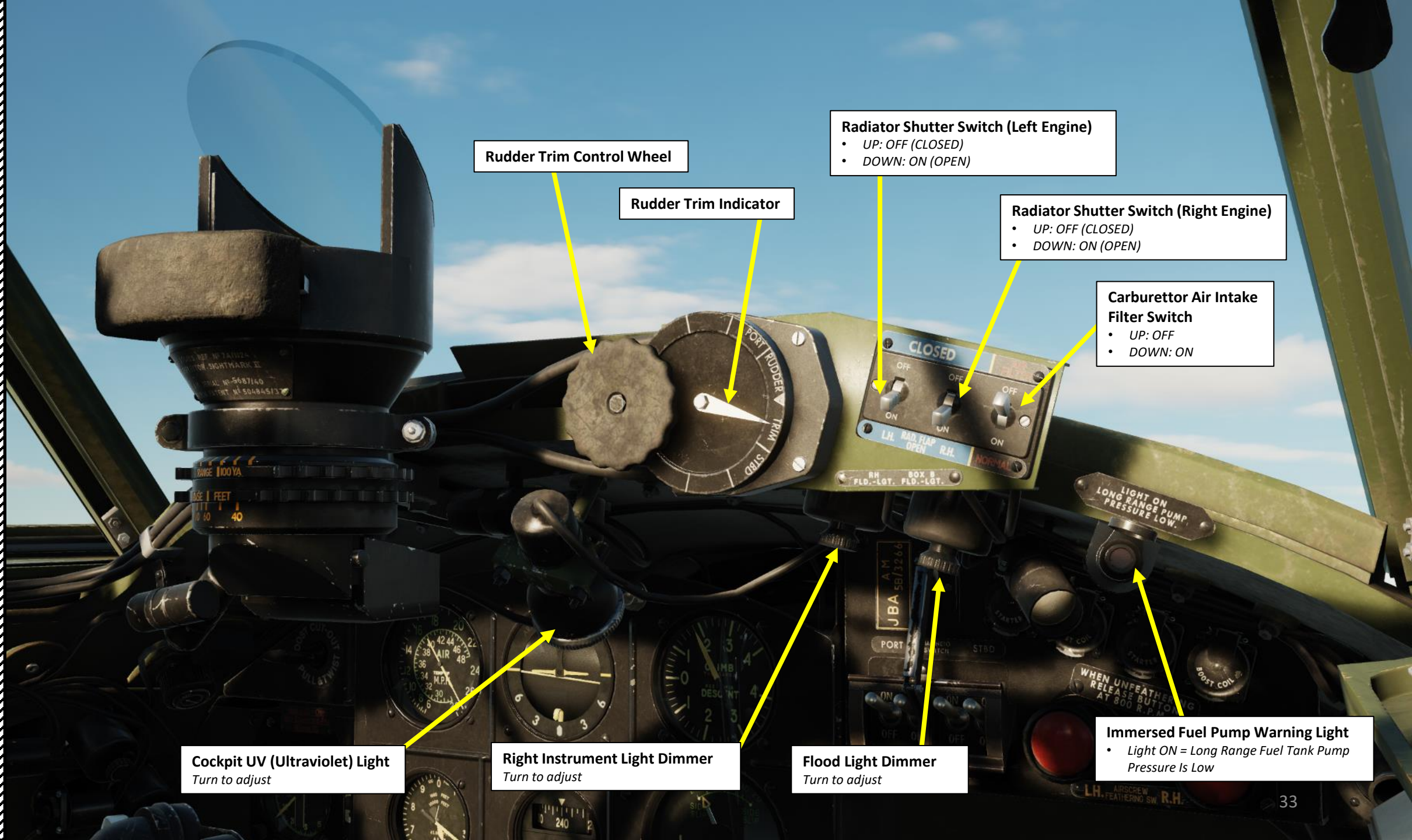

Rudder Trim Control Wheel

Rudder Trim Indicator

Radiator Shutter Switch (Left Engine)
• UP: OFF (CLOSED)
• DOWN: ON (OPEN)

Radiator Shutter Switch (Right Engine)
• UP: OFF (CLOSED)
• DOWN: ON (OPEN)

Carburettor Air Intake Filter Switch
• UP: OFF
• DOWN: ON

Cockpit UV (Ultraviolet) Light
Turn to adjust

Right Instrument Light Dimmer
Turn to adjust

Flood Light Dimmer
Turn to adjust

Immersed Fuel Pump Warning Light
• Light ON = Long Range Fuel Tank Pump Pressure Is Low



Boost Control Cut-Out Handle
• Not Functional on this variant of the Mosquito (Merlin 25 engines)

Remote Indicating (R.I.) Repeater Compass





Tachometer (Left Engine)
Inner Needle: x1000 RPM
Outer Needle: x 100 RPM

Tachometer (Right Engine)
Inner Needle: x1000 RPM
Outer Needle: x 100 RPM

**Boost Indicator (psi)
(Left Engine)**
• Similar to manifold pressure

**Boost Indicator (psi)
(Right Engine)**
• Similar to manifold pressure

**Low Fuel Pressure Warning Light
(Left Engine)**
Illuminates when main fuel pump
pressure drops below 10 psi

**Low Fuel Pressure Warning Light
(Right Engine)**
Illuminates when main fuel pump
pressure drops below 10 psi

**Oil Pressure Indicator (psi)
(Left Engine)**

**Oil Pressure Indicator (psi)
(Right Engine)**

**Oil Temperature Indicator (deg C)
(Left Engine)**

**Oil Temperature Indicator (deg C)
(Right Engine)**

**Radiator Coolant Temperature Indicator (deg C)
(Left Engine)**

**Radiator Coolant Temperature Indicator (deg C)
(Right Engine)**

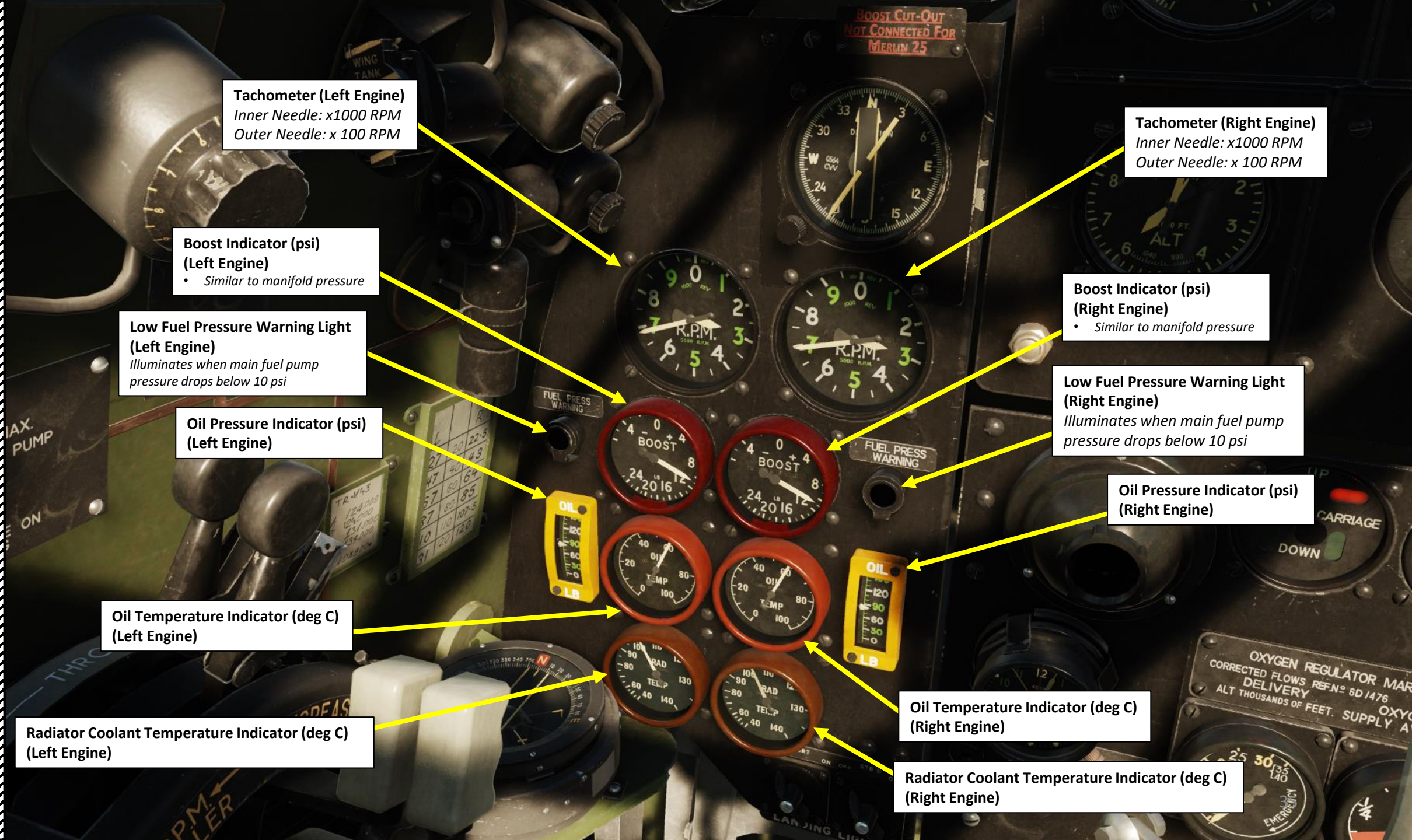

BOOST CUT-OUT
NOT CONNECTED FOR
MERLIN 25

WING
TANK

MAX.
PUMP
ON

TR. 124 200
124 200
131 200
131 200
137 80 64
10 100 107.5
31 120 120

OXYGEN REGULATOR MARK
CORRECTED FLOWS REF. NO. 6D/476
DELIVERY OXYGEN
ALT. THOUSANDS OF FEET. SUPPLY A

LAR JING LIGHT

25 30 35
140
EMERGENCY

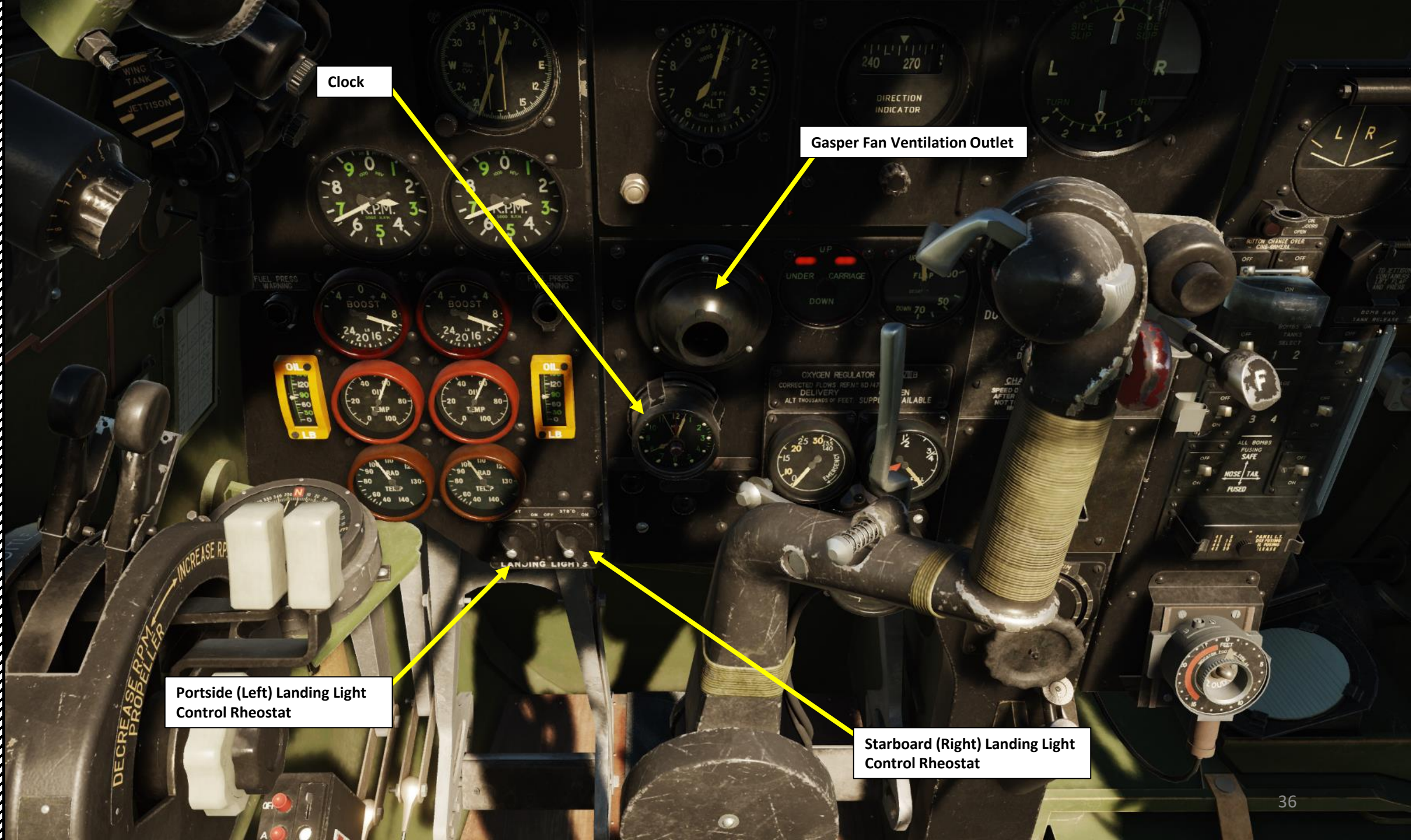

Clock

Gasper Fan Ventilation Outlet

Portside (Left) Landing Light Control Rheostat

Starboard (Right) Landing Light Control Rheostat



Airspeed Indicator (mph)

Outer scale: airspeed from 60 to 280 mph
Inner scale: airspeed from 280 to 480 mph

- Note: the pilot needs to determine by himself whether the aircraft speed is within the outer or the inner scale since there is only one airspeed needle.



Attitude Indicator



Vertical Speed Indicator (x1000 ft/min)



Turn and Slip Indicator



Altimeter

Longest needle: x100 ft
Medium Thick needle: x1000 ft
Short Thin needle: x10000 ft

Example:

Altitude read = 260 ft + 4000 ft = 4260 ft



Directional Gyro Adjustment Control Knob

Directional Gyro

Altimeter Barometric Pressure Setting (mBar/hPa)

Altimeter Barometric Pressure Adjustment Knob





Landing Gear (Undercarriage) Position Indicator

- UP (Red Light)
- DOWN (Green Light)

Flaps Position Indicator (deg)

Landing Gear Control Lever Safety Catch

- Shown locked. Prevents the landing gear lever from going to the UP position in order to prevent inadvertent landing gear detraction when the aircraft is on the ground.

Flaps Control Lever Safety Catch

- Shown locked. Prevents the flap lever from going to the DOWN position in order to prevent inadvertent flap deployment during flight at high speeds.

Landing Gear (Undercarriage) Position Indicator Blinder

- Turn knob to set a filter that dims the undercarriage position lights

Bomb Doors Selector

- UP: Bomb Doors Closed
- DOWN: Bomb Doors Open

Landing Gear (Undercarriage) Control Lever

- UP: Gear Up
- MIDDLE: Gear Neutral (landing gear stays in current position)
- DOWN: Gear Down

Flaps Selector Lever

- UP: Flaps Retracted
- MIDDLE: Neutral (flaps stay in current position)
- DOWN: Flaps Deployed

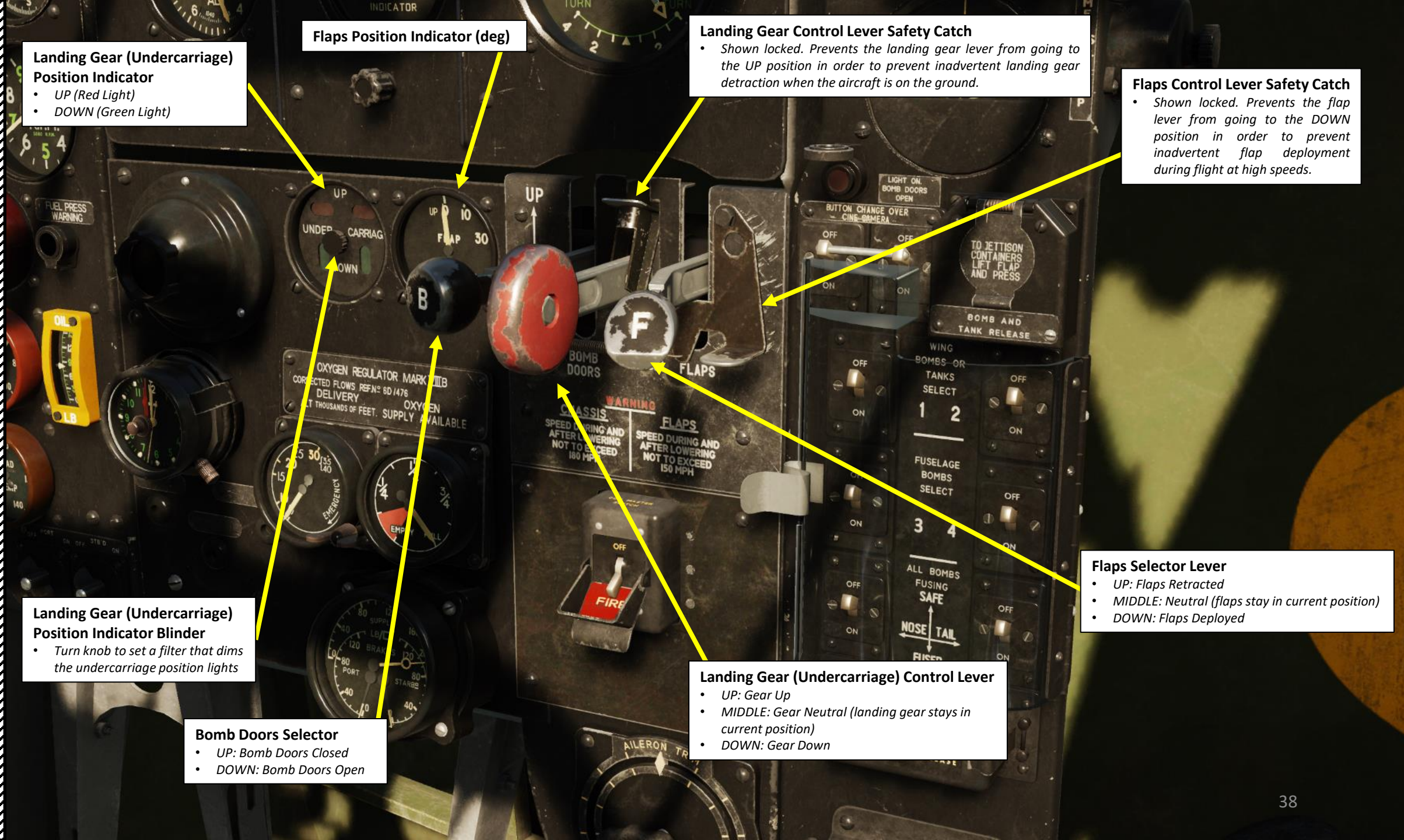



Pilot Oxygen
Quantity Indicator

Pilot Oxygen Pressure
Indicator (psi)

OXYGEN REGULATOR MARK VIII
CORRECTED FLOWS REEN^o 8D/476
DELIVERY OXYGEN
ALT THOUSANDS OF FEET SUPPLY AVAILABLE

Oxygen Valve Control
(shown open)

Triple Pressure Gauge
(Brake Pneumatic Pressure) (psi)

UP
DOWN
B
F
BOMB DOORS
CHASSIS
FLAPS
WARNING
CHASSIS SPEED DURING AND AFTER LOWERING NOT TO EXCEED 180 MPH
FLAPS SPEED DURING AND AFTER LOWERING NOT TO EXCEED 150 MPH

Gun Master Arm Switch
• UP: Master Arm OFF, guns and cannon cannot fire.
• DOWN: Master Arm ON, guns and cannon can fire.

Gun Master Arm Cover Guard

LIGHT ON BOMB DOORS OPEN
BUTTON CHANGE OVER CINE-CAMERA
TO JETTISON CONTAINERS LIFT FLAP AND PRESS
BOMB AND TANK RELEASE
WING BOMBS-OR TANKS SELECT
FUSELAGE BOMBS SELECT
ALL BOMBS FUSING SAFE



Aileron Trim Indicator



Gun Camera Footage Indicator

• Footage Tape Length (in feet).
If the gun camera switch is set to ON and the machineguns/cannons are being fired, the gun camera mounted in the aircraft nose records footage. In the 1940's, gun camera footage was recorded on 16 mm tape.



Aileron Trim Control Wheel



Camera Footage Exposure Switch

- UP: Sunny Conditions
- DOWN: Cloudy Conditions



De-Icing Glycol Pump Lever





DH.98 MOSQUITO
FB MK VI

PART 3 - COCKPIT & EQUIPMENT



JBA (Junction Box A)

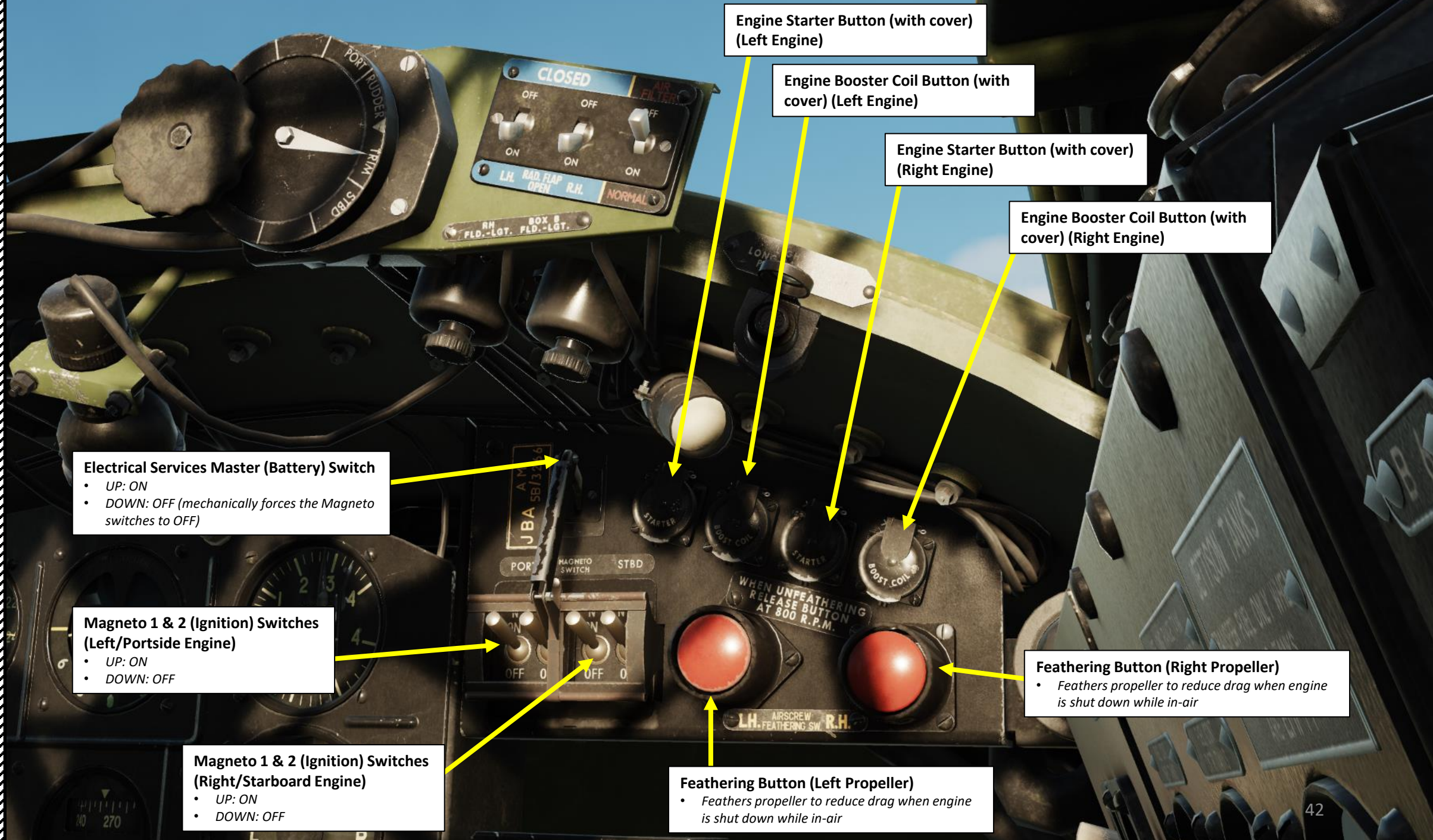

Engine Starter Button (with cover)
(Left Engine)

Engine Booster Coil Button (with
cover) (Left Engine)

Engine Starter Button (with cover)
(Right Engine)

Engine Booster Coil Button (with
cover) (Right Engine)

Electrical Services Master (Battery) Switch
• UP: ON
• DOWN: OFF (mechanically forces the Magneto
switches to OFF)

Magneto 1 & 2 (Ignition) Switches
(Left/Portside Engine)
• UP: ON
• DOWN: OFF

Magneto 1 & 2 (Ignition) Switches
(Right/Starboard Engine)
• UP: ON
• DOWN: OFF

Feathering Button (Left Propeller)
• Feathers propeller to reduce drag when engine
is shut down while in-air

Feathering Button (Right Propeller)
• Feathers propeller to reduce drag when engine
is shut down while in-air



Gasper Fan Ventilation Outlet



DH.98 MOSQUITO
FB MK VI

PART 3 - COCKPIT & EQUIPMENT





Direction Finding Left (L) Needle
To navigate towards D/F emitter, needle must be centered

Direction Finding (DF) Visual Indicator

Bomb Control Panel Flood Light Dimmer

Direction Finding Right (R) Needle
To navigate towards D/F emitter, needle must be centered

Bomb Doors Warning Light
Illuminates when bomb doors are OPEN

Bomb Containers and Wing Drop Tanks Jettison Button (with cover guard)

Bombs or Camera Changeover Switch
Sets the function of the Bomb Release & Gun Camera (Guncam) Button
• UP: OFF (Gun Cine Camera Selected, Bombs not Selected)
• DOWN: ON (Bombs Selected, Gun Cine Camera not Selected)

Wing Bombs 2 (or Tank) Selector Switch
• UP: OFF
• DOWN: ON (Selected)

Wing Bombs 1 (or Tank) Selector Switch
• UP: OFF
• DOWN: ON (Selected)

Bomb Control Panel Protective Glass

Bomb Control Panel Protective Glass Handle (click to open or close the glass)

Inner Bay Bombs 4 Selector Switch
• UP: OFF
• DOWN: ON (Selected)

Inner Bay Bombs 3 Selector Switch
• UP: OFF
• DOWN: ON (Selected)

Bomb Tail Fuzing Switch
• UP: Fuze OFF
• DOWN: Fuze ARMED

Bomb Nose Fuzing Switch
• UP: Fuze OFF
• DOWN: Fuze ARMED

Bomb Fusing Box



Drift Scale

A drift meter consists of a small telescope extended vertically through the bottom of the aircraft with the eyepiece inside the fuselage at the navigator's station. A reticle, normally consisting of spaced parallel lines, is rotated until objects on the ground are seen to be moving parallel to the vertical lines. The angle of the reticle then indicates the aircraft's drift angle due to winds aloft. It is also used to calculate the ground speed by measuring the time it takes for an object on the ground to pass from the upper to the lower horizontal line of the reticle.

Drift sights were used to estimate the sideways drift over the ground caused by crosswind. Calculating drift is important for both high level bombing and long distance navigation. This is particularly relevant for over water navigation due to the absence of ground references to obtain fixes.

Feel free to consult this link for museum photos:

<https://www.britmodeller.com/forums/index.php?/topic/235068711-mosquito-fbvi-drift-sight-questions/&do=findComment&comment=3597530>

Periscopic Drift Sight

Stowed Position. When in use, the sight is slid to the right so that the periscope head is outside the aircraft looking down.

Periscope Head
Access Door

Drift Recorder



Oxygen High Pressure Valve Control

- Clockwise: Valve Open (ON)
- Counter-Clockwise: Valve Closed (OFF)

Navigator Oxygen
Pressure Indicator (psi)

Navigator Oxygen
Quantity Indicator

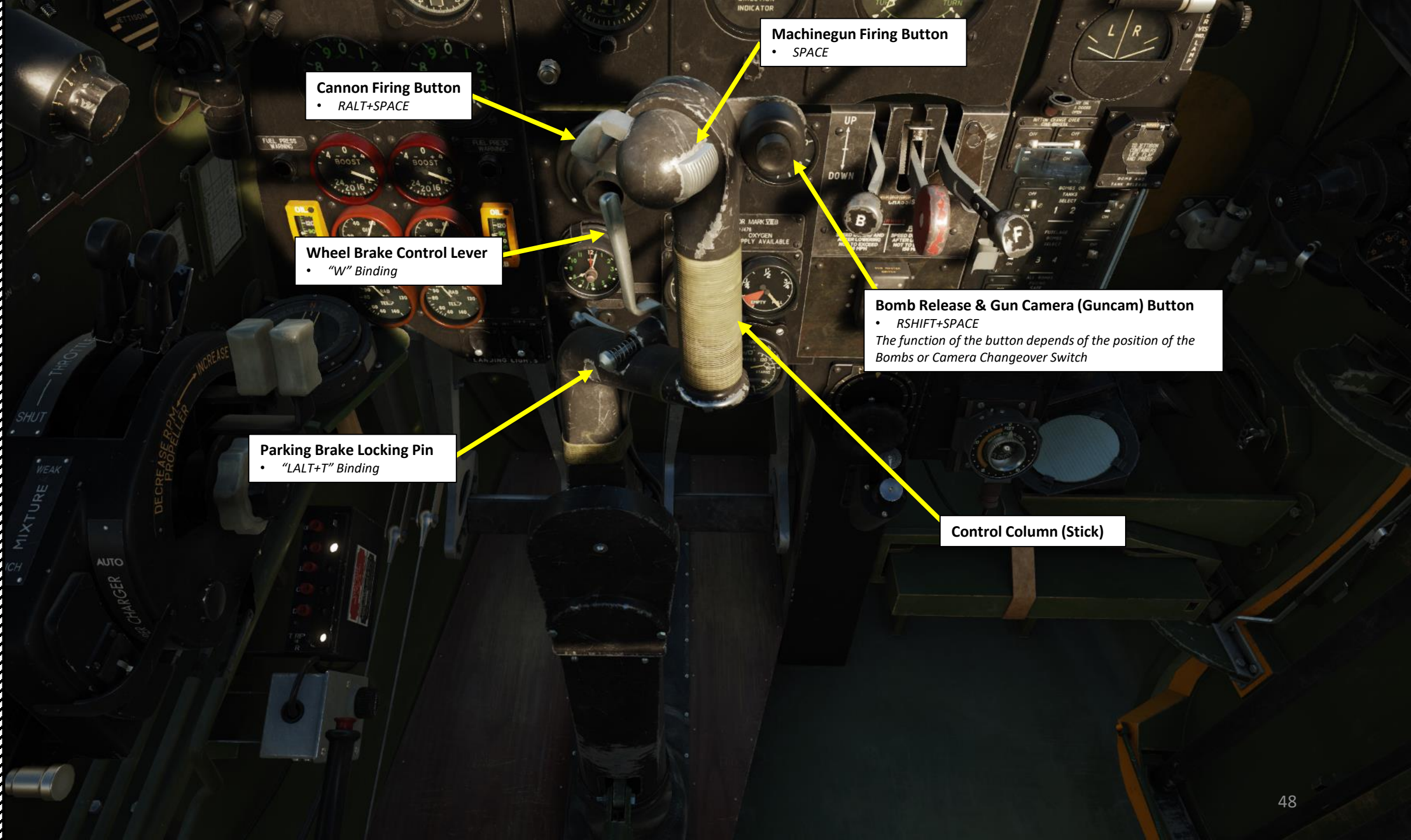

Cannon Firing Button
• RALT+SPACE

Machinegun Firing Button
• SPACE

Wheel Brake Control Lever
• "W" Binding

Bomb Release & Gun Camera (Guncam) Button
• RSHIFT+SPACE
The function of the button depends of the position of the Bombs or Camera Changeover Switch

Parking Brake Locking Pin
• "LALT+T" Binding

Control Column (Stick)



DH.98 MOSQUITO
FB MK VI

PART 3 - COCKPIT & EQUIPMENT



Rudder Pedals



DH.98 MOSQUITO
FB MK VI

PART 3 – COCKPIT & EQUIPMENT



Right Window Lock



JBB (Junction Box B)



Ultraviolet (UV) Lights Switch

- DOWN: ON
- UP: OFF

Navigation Lights Switch

- DOWN: ON
- UP: OFF

**Cine-Camera (Gun Camera)
Master Switch**

- DOWN: ON
- UP: OFF

Pressure-Head (Pitot Tube) Heater Switch

- DOWN: ON
- UP: OFF

Immersed Fuel Pump Switch

- DOWN: ON
- UP: OFF

Reflector Gunsight Power Switch

- DOWN: ON
- UP: OFF

**IFF (Identify-Friend-or-Foe)
Detonator Pushbuttons**

Fire Extinguisher Pushbutton

Portside (Left) Engine

Fire Extinguisher Pushbutton

Starboard (Right) Engine

Navigation Head Lamp Switch

- DOWN: ON
- UP: OFF

**R3078 IFF (Identify-Friend-or-Foe)
Transceiver Power Switch**

- DOWN: ON
- UP: OFF

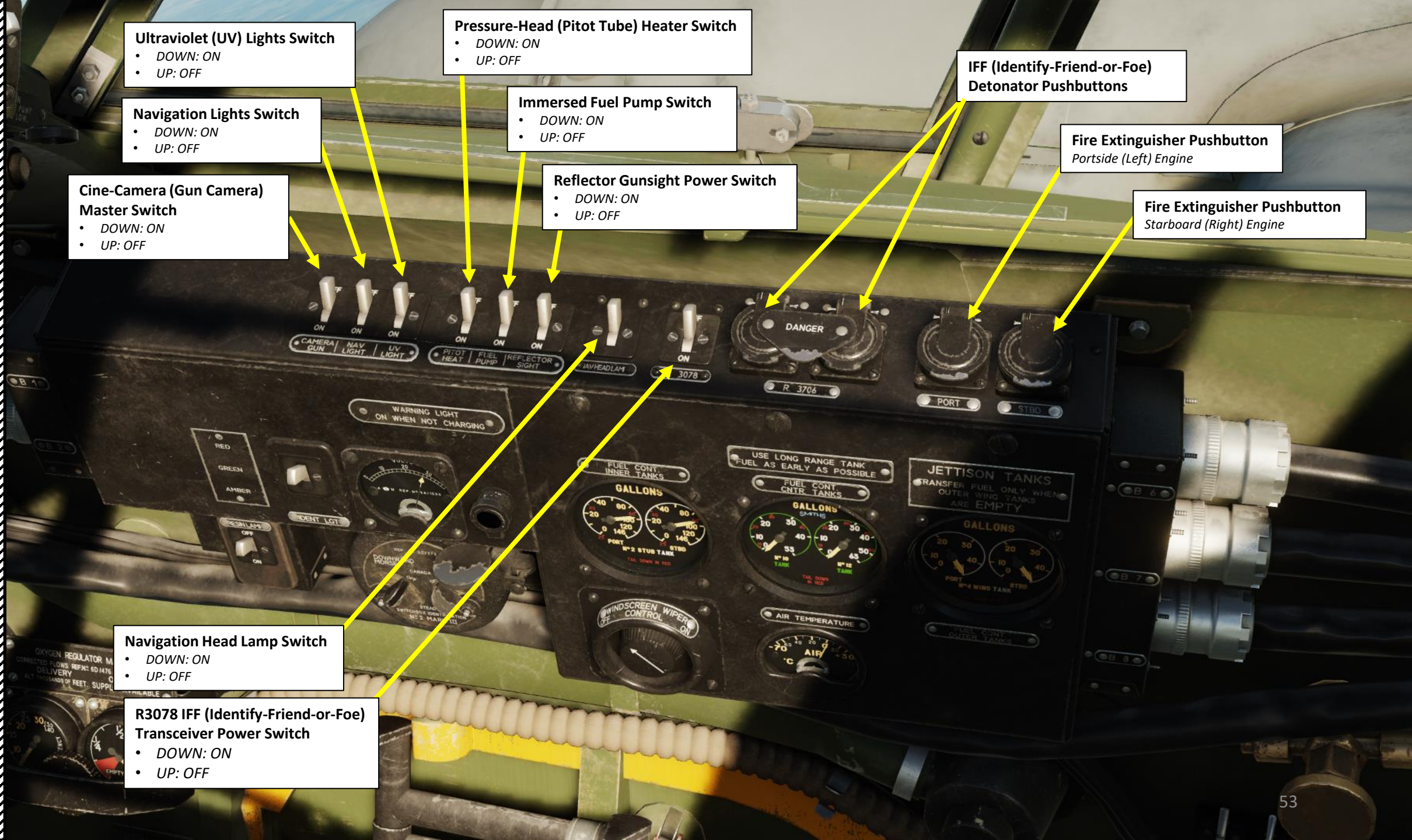

**Identification Lights
Color Selector Switch**

- UP: Red
- MIDDLE: Green
- DOWN: Amber

**RESIN (Restricted Intensity)
Lamps Switch**

- UP: OFF
- DOWN: ON

**Lower Identification (Air Recognition) Light Control
Switch**

- STEADY (AFT) – Constantly illuminates
- OFF (MID)
- MORSE (FWD) – Illuminates when Morse switch is pressed

**Upper Identification (Air
Recognition) Light Control Switch
(Not Functional in the Mosquito)**

Identification Light Morse switch

Used to toggle identification lights to send morse signals



Voltmeter (Volts)

Generator Warning Light

Illuminated when generator is not charging

Fuel Contents Gauges (Inner Wing Fuel Tanks)
(Imperial Gallons)

Fuel Contents Gauges (Center Fuel Tanks)
(Imperial Gallons)

Fuel Contents Gauges (Outer Wing Fuel Tanks)
(Imperial Gallons)

Windscreen Wiper Rheostat

- Clockwise: Wipers Operating
- Counter-Clockwise: Wipers Stopped

Outside Air Temperature Indicator (deg C)

Fuel Contents Gauges (Long-Range Tank if fitted)
(Imperial Gallons)

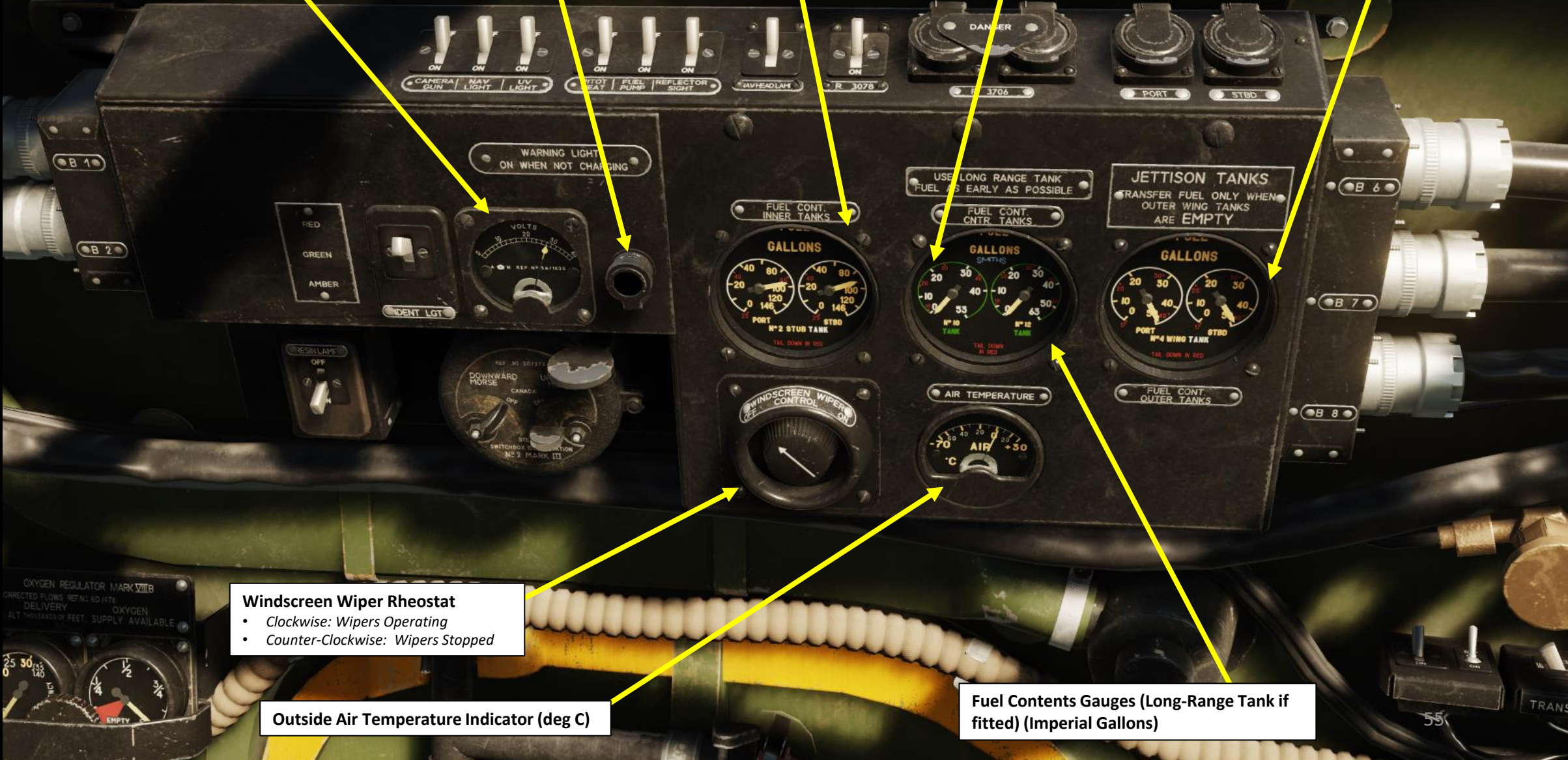

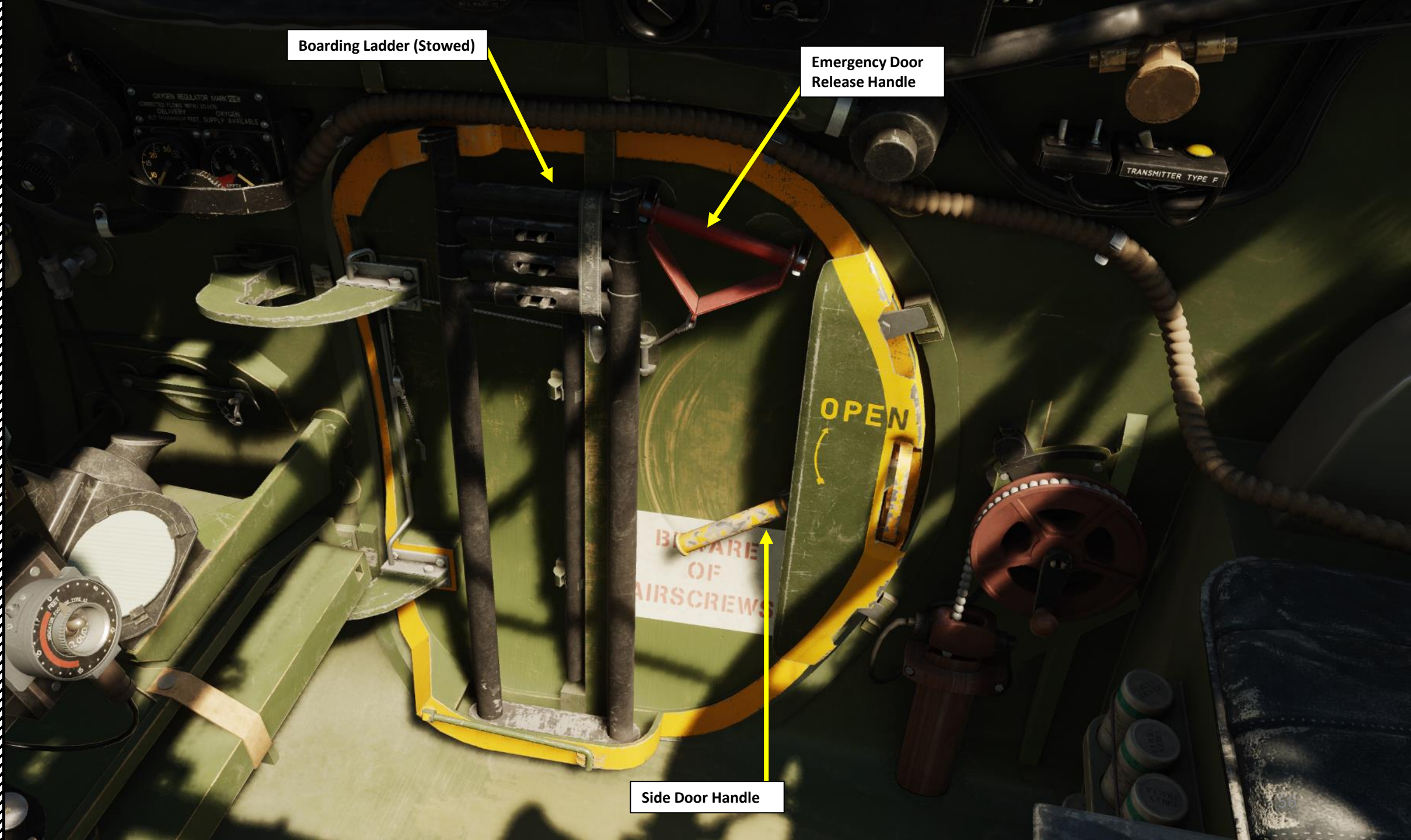

Boarding Ladder (Stowed)

Emergency Door Release Handle

Side Door Handle

MF Trailing Antenna Wire

In certain variants of the Mosquito, in order to communicate on MF (medium frequencies), a long “trailing” antenna had to be reeled out of the plane. The antenna would have to be reeled back in in order to avoid having the wire tangled up in trees or electrical power lines.

**MF Trailing Antenna Reel
Winch Brake Lever**

- FWD: Brake ON
- AFT: Brake OFF

MF Trailing Antenna Reel Winch

- Left Click: Cranks counter-clockwise (extends antenna wire)
- Right Click: Cranks clock-wise (retracts antenna wire)



DH.98 MOSQUITO
FB MK VI

PART 3 – COCKPIT & EQUIPMENT



Hydraulic Hand Pump Socket

Note: The hand pump handle is under the pilot seat and has to be screwed in the socket. Hand-pumping the landing gear down takes 4 minutes to build up enough pressure to successfully deploy and lock the landing gear for landing.

**Hydraulic Hand
Pump Handle**

Signal Flare
Cartridges

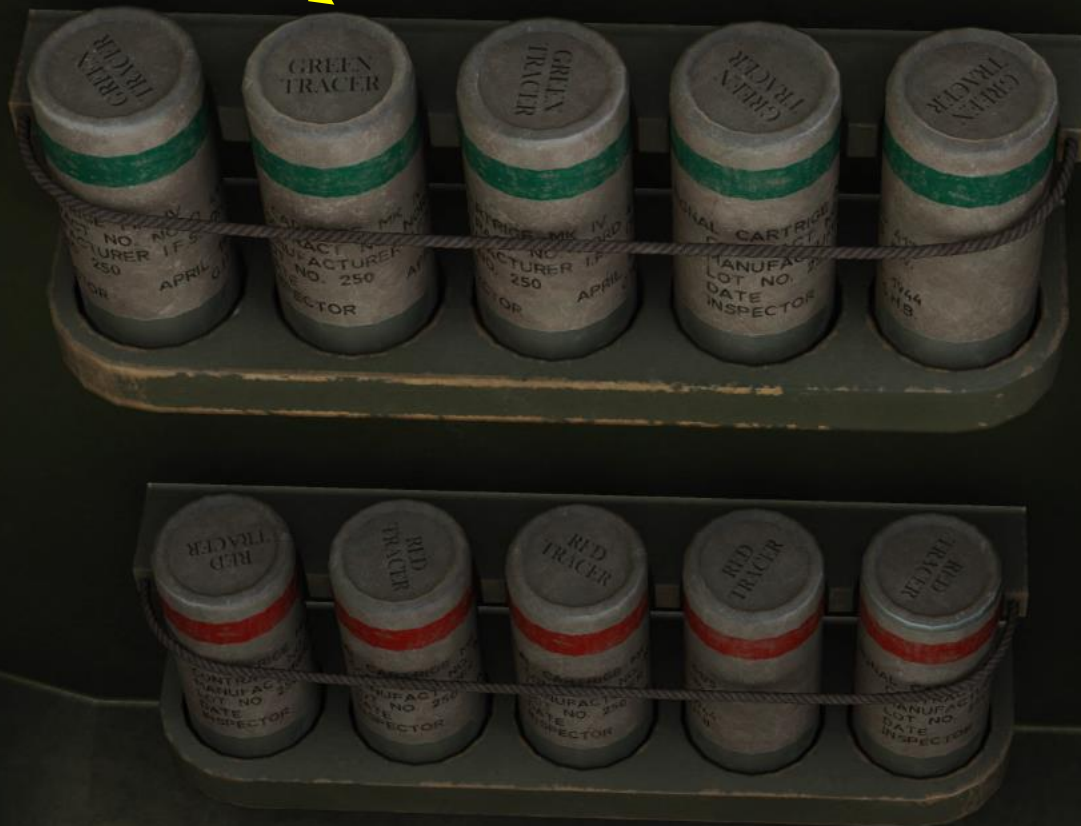

Oxygen Bottle



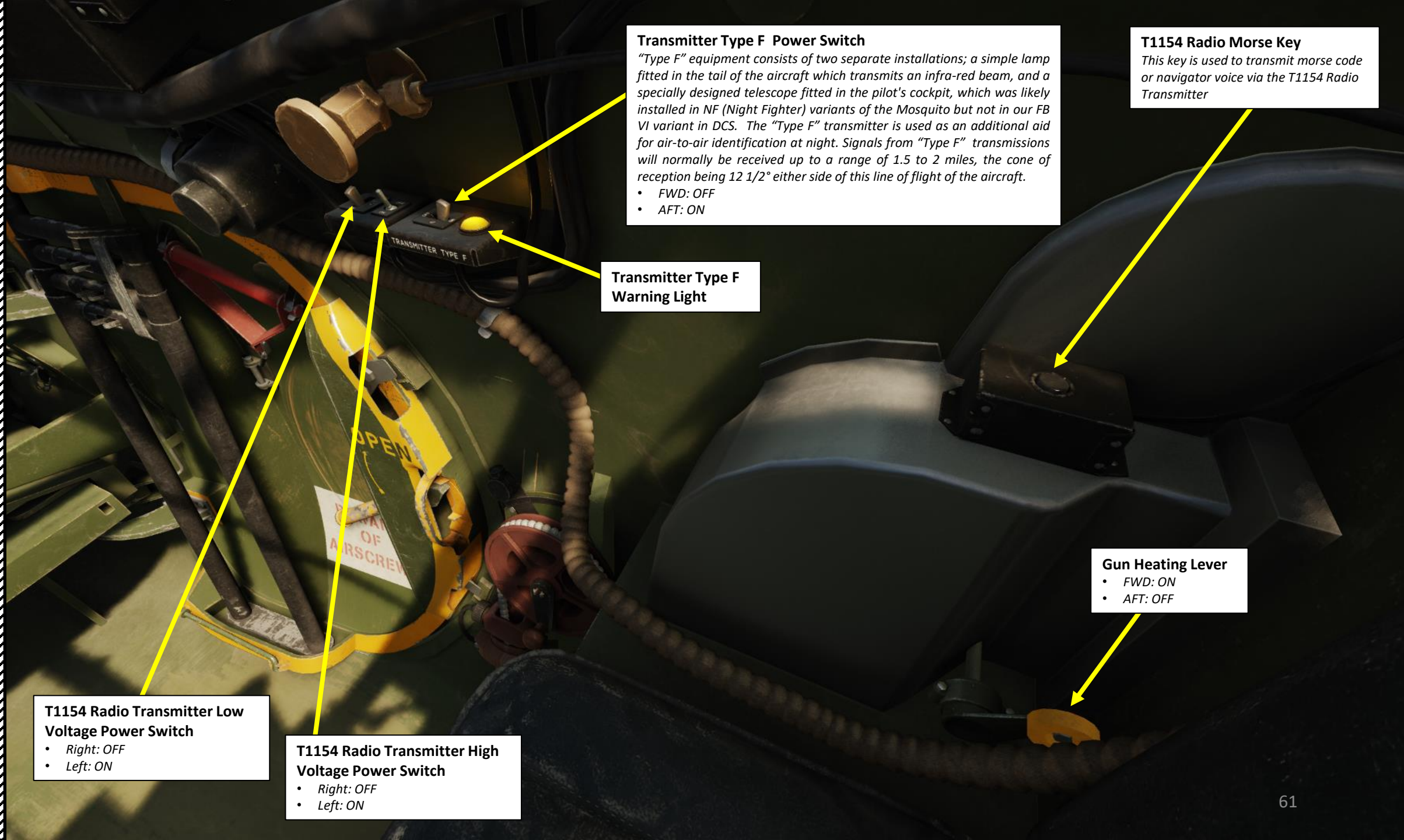

Transmitter Type F Power Switch
"Type F" equipment consists of two separate installations; a simple lamp fitted in the tail of the aircraft which transmits an infra-red beam, and a specially designed telescope fitted in the pilot's cockpit, which was likely installed in NF (Night Fighter) variants of the Mosquito but not in our FB VI variant in DCS. The "Type F" transmitter is used as an additional aid for air-to-air identification at night. Signals from "Type F" transmissions will normally be received up to a range of 1.5 to 2 miles, the cone of reception being 12 1/2° either side of this line of flight of the aircraft.

- FWD: OFF
- AFT: ON

T1154 Radio Morse Key
 This key is used to transmit morse code or navigator voice via the T1154 Radio Transmitter

Transmitter Type F Warning Light

Gun Heating Lever

- FWD: ON
- AFT: OFF

T1154 Radio Transmitter Low Voltage Power Switch

- Right: OFF
- Left: ON

T1154 Radio Transmitter High Voltage Power Switch

- Right: OFF
- Left: ON

PART 3 – COCKPIT & EQUIPMENT

DH.98 MOSQUITO
FB MK VI





DH.98 MOSQUITO
FB MK VI

PART 3 - COCKPIT & EQUIPMENT

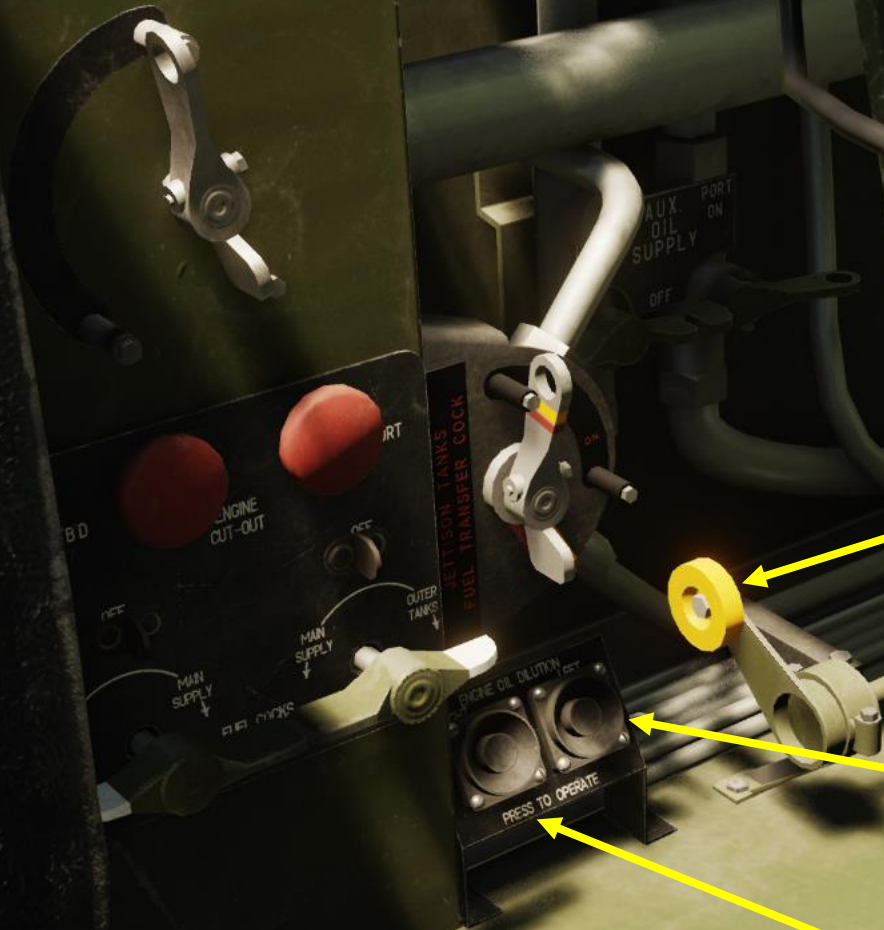

Cockpit Heating Lever
• FWD: ON
• AFT: OFF

Left Engine Oil Dilution Button (Press to Operate)

Right Engine Oil Dilution Button (Press to Operate)

Fuel Tank Pressurization (Fuel Venting Cock) Control Handle

- Vertical Position (Shown): Fuel Pressurization ON.
- Horizontal Position: Fuel Pressurization OFF.

Auxiliary Oil Supply Control Handle

- Vertical Position: OFF
- Horizontal Position (Shown): ON. This provides extra oil pressure boost for the left engine (left handle) or right engine (right handle) and enables the supply of lubricant from an external power supply.

Fuel Transfer Valve Control Handle

- Vertical Position (Shown): Fuel Transfer Valve Close (OFF)
- Horizontal Position: Fuel Transfer Valve Open (ON). Fuel pumps transfer fuel from the underwing tanks to the outer wing tanks



Right Engine Fuel Cut-Out Handle

- Pulled OUT: Fuel Valve Closed (Engine Cut-Out)
- Pushed IN: Fuel Valve Open

Left Engine Fuel Cut-Out Handle

- Pulled OUT: Fuel Valve Closed (Engine Cut-Out)
- Pushed IN: Fuel Valve Open

Right Engine Fuel Cock Selector

- Left: Outer Wing Tanks
- Vertical: OFF
- Right: Main Supply

Position of the selector is indicated by the white end of the handle.

Left Engine Fuel Cock Selector

- Right: Outer Wing Tanks
- Vertical: OFF
- Left: Main Supply

Position of the selector is indicated by the white end of the handle.

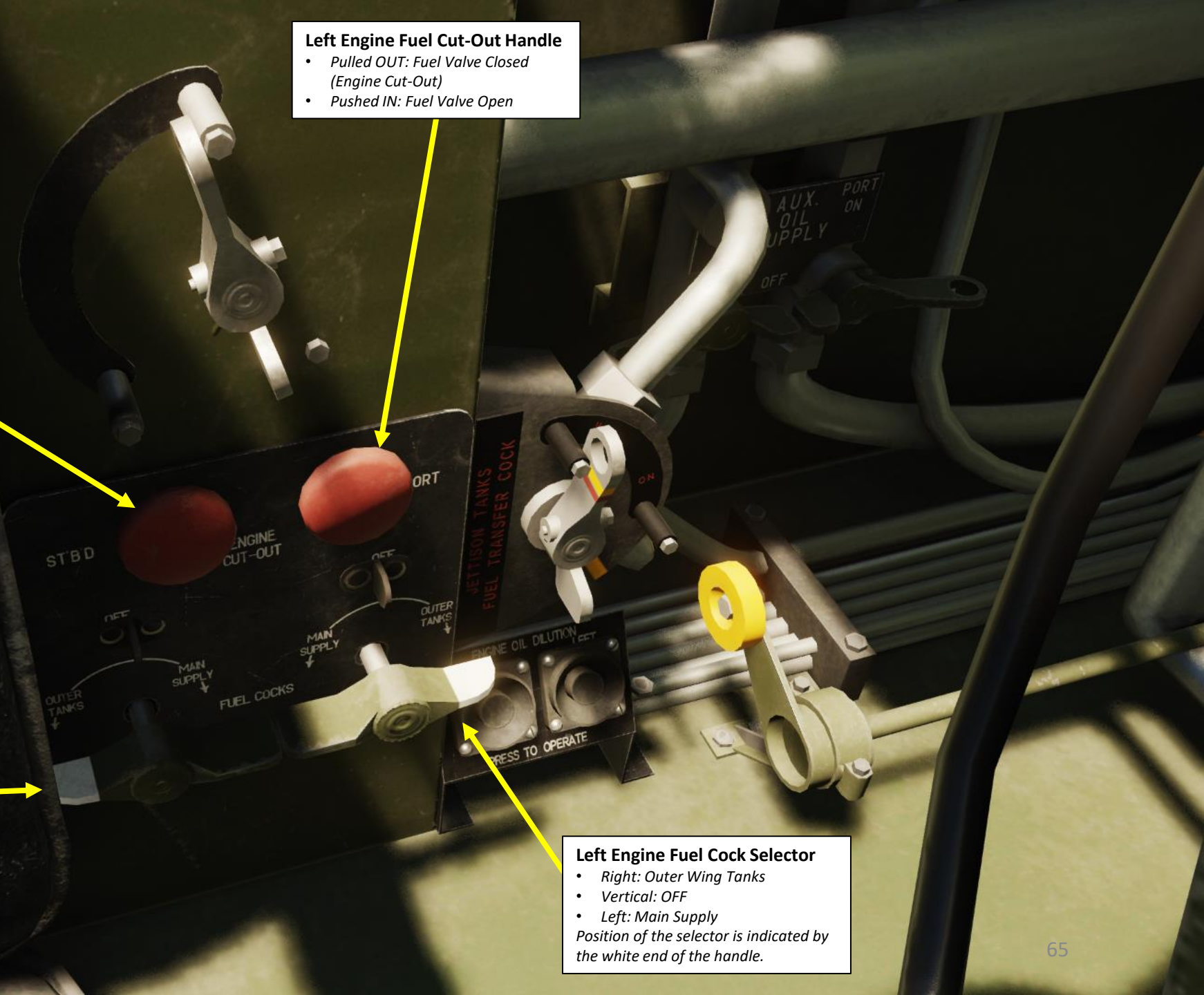



DH.98 MOSQUITO
FB MK VI

PART 3 – COCKPIT & EQUIPMENT



Armored
Headrest

Armored Headrest Handle
*Click on handle to allow the navigator
to access rear compartment.*



Socket for the Very Signal Flare Gun

The flare gun was used to identify yourself when approaching a landing airfield or when being illuminated by friendly search lights. The navigator was equipped with a chart with corresponding flare color for the appropriate time of day. The required identification colors changed every 2 hours.





DH.98 MOSQUITO
FB MK VI

PART 3 – COCKPIT & EQUIPMENT



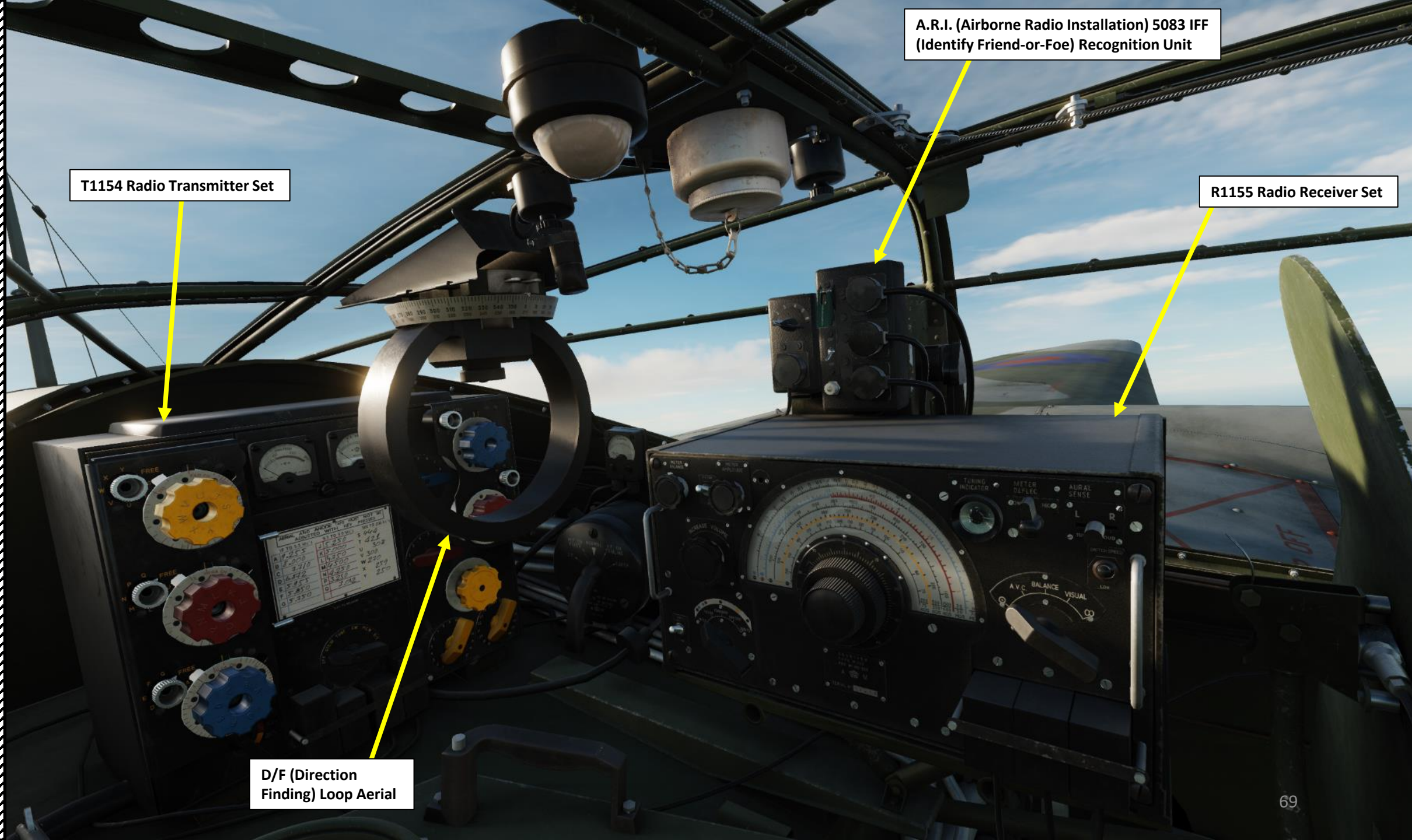

T1154 Radio Transmitter Set

A.R.I. (Airborne Radio Installation) 5083 IFF
(Identify Friend-or-Foe) Recognition Unit

R1155 Radio Receiver Set

D/F (Direction Finding) Loop Aerial



Dome Light

Loop Aerial
Light Dimmer

D/F Loop Aerial Lock
*Locks the scale directional
marking scale in position.*

D/F (Direction
Finding) Loop Aerial
(Antenna)

Dome Light Dimmer

Loop Aerial Light

D/F (Direction
Finding) Loop Aerial
Directional Markings

AERIAL AND ANODE TAPS MUST NOT BE ADJUSTED WITH KEY PRESSED

	10 TO 5.5 Mc's	5.5 TO 3.0 Mc's	300 TO 200 KC's
A	9.255	J 5.250	S 444
B	8.000	K 5.000	T 421
C	7.710	L 4.750	U 303
		M 4.500	V 300
			W 370



A.R.I. 5083 IFF Detonator Switch
Used to destroy the IFF system.

**A.R.I. (Airborne Radio Installation) 5083 IFF
(Identify Friend-or-Foe) Recognition Unit**

**A.R.I. 5083 IFF
Channel Selector**

A.R.I. 5083 IFF Power Switch

- UP: ON
- DOWN: OFF





Filter Switch
Switches between the meter balance and meter amplitude controls, so that the L/F filter may be switched off if desired.

Meter Amplitude Control
Adjusts the needles of the visual indicator to a convenient point on the meter scale

Heterodyne Pre-set Adjustment
Semi-variable condenser, with screwdriver adjustment which varies the beat frequency.

Receiver Tuning Indicator Light (“Magic Eye”)

Meter Deflection Sensitivity Switch
Provides comparatively LOW sensitivity of the visual indicator for homing purposes, or HIGH sensitivity of the visual indicator when taking bearings by the visual method.

Aural Sense Switch

- L: Left sense determination using aural Direction Finding
- R: Right sense determination using aural Direction Finding
- Central position: OFF

Meter Frequency Switch
Alters the switching frequency from 30 (LOW) to 80 (HIGH) cycles per second.

R1155 Radio Receiver Set Master Selector Switch

- **Omni (O):** All round reception.
- **A.V.C.:** Gives automatic volume control.
- **Balance.:** for Visual D/F (Direction Finding), for the purpose of matching the circuits and valves associated with the visual indicator.
- **Visual D/F.:** In this position, A.V.C. is in use.
- **Figure-of-Eight (∞):** Aural Direction Finding, bearings are taken on aural nulls, using the bandswitch for sense determination. The H/F gain is manually controlled, the A.V.C. being disconnected.

R1155 Radio Receiver Set Frequency Range Switch

- **18/7.5:** Range from 18.5 MHz to 7.5 MHz (H/F)
- **7.5/3.0:** Range from 7.5 MHz to 3.0 MHz (H/F, used for Directional Finding)
- **1500/600:** Range from 1500 KHz to 600 KHz (M/F, used for Directional Finding)
- **500/200:** Range from 500 KHz to 200 KHz (M/F, used for Directional Finding)
- **200/75:** Range from 200 KHz to 75 KHz (M/F, used for Directional Finding)

R1155 Radio Receiver Set

Meter Balance Control
Is in circuit when the Master Switch is in either the BALANCE or VISUAL position.

Volume Control

Heterodyne Switch

- UP: BFO OFF
- DOWN: BFO ON

Switches on or off the beat frequency oscillator (BFO)

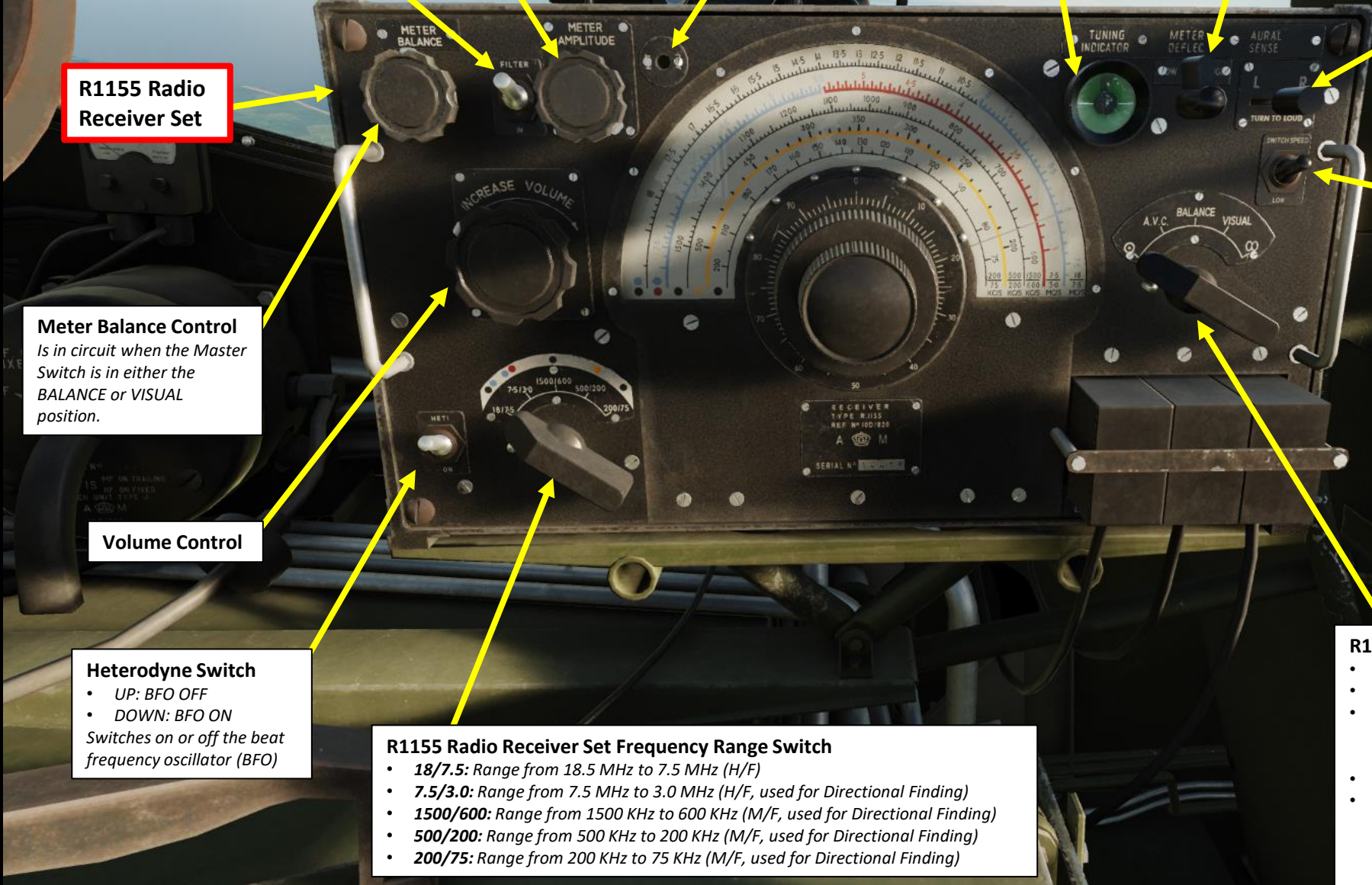



R1155 Radio Receiver Set Tuning Scale

- **Black Range:** from 18.5 MHz to 10 MHz
- **Blue Range:** from 10 MHz to 7.5 MHz

R1155 Radio Receiver Set Tuning Scale

- **Blue Range:** from 7.5 MHz to 5.5 MHz
- **Red Range:** from 5.5 MHz to 3.0 MHz

R1155 Radio Receiver Set Tuning Scale

- **Black Range:** from 1500 KHz to 600 KHz

R1155 Radio Receiver Set Tuning Scale

- **Yellow Range:** from 500 KHz to 200 KHz

R1155 Radio Receiver Set Tuning Scale

- **Black Range:** from 200 KHz to 75 KHz

R1155 Radio Receiver Set Tuning Controls

- Use largest/outer knob for coarse tuning frequency signal
- Use smaller/inner knob for fine tuning frequency signal

Receiver Tuning Indicator Pointer

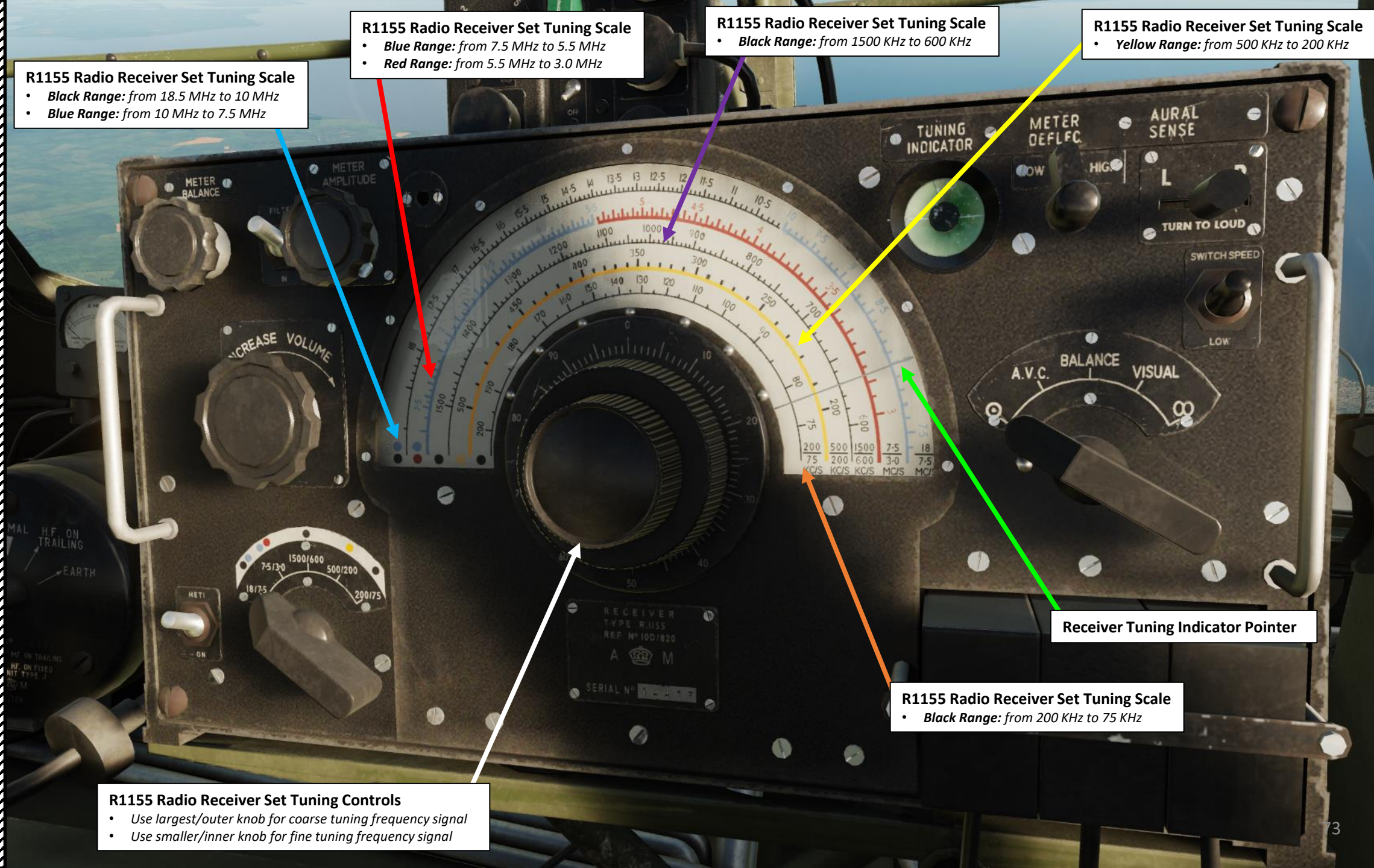



T1154 Radio Transmitter Set

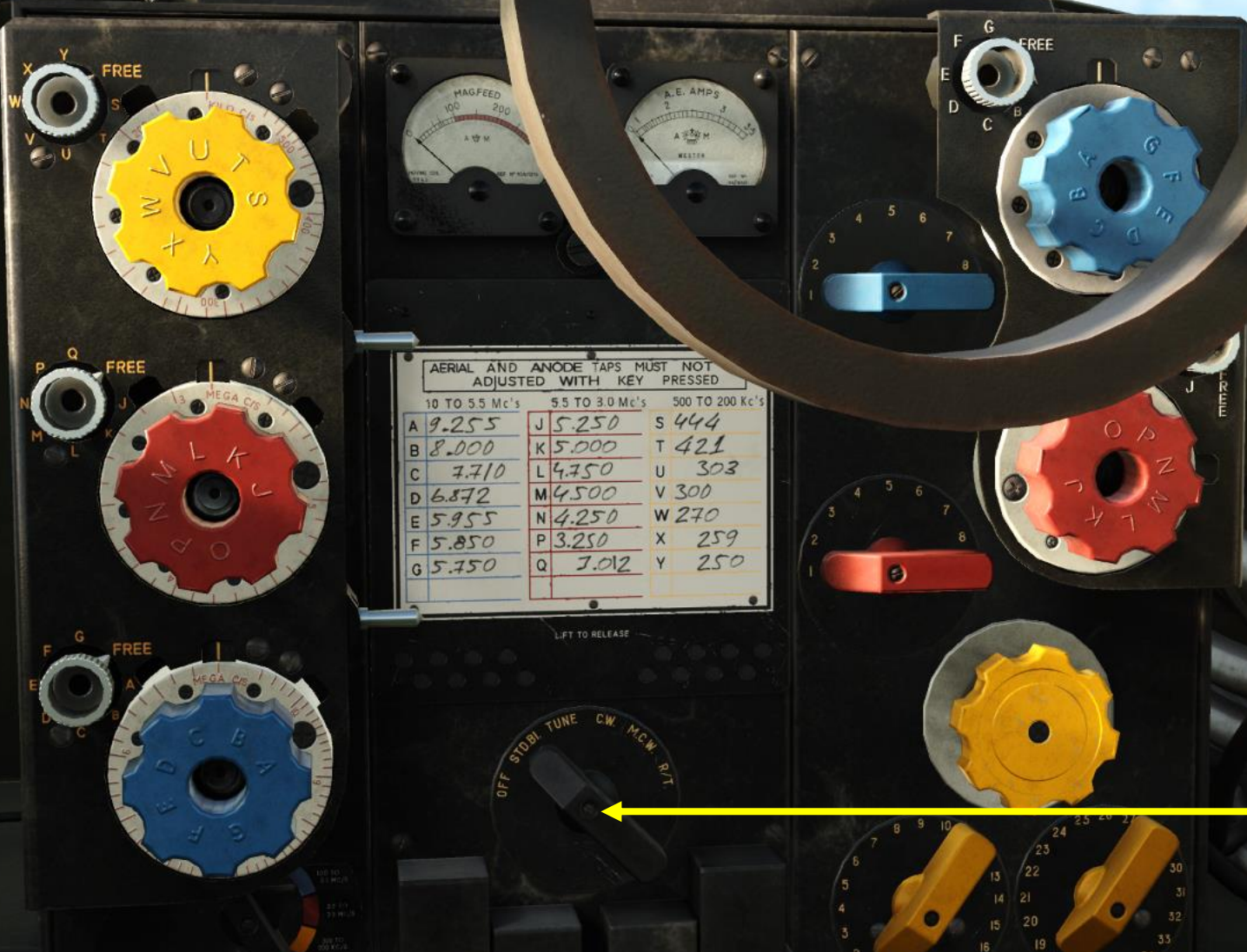

AERIAL AND ANODE TAPS MUST NOT ADJUSTED WITH KEY PRESSED

10 TO 5.5 Mc's		5.5 TO 3.0 Mc's		500 TO 200 Kc's	
A	9.255	J	5.250	S	444
B	8.000	K	5.000	T	421
C	7.710	L	4.750	U	303
D	6.872	M	4.500	V	300
E	5.955	N	4.250	W	270
F	5.850	P	3.250	X	259
G	5.750	Q	3.012	Y	250

T1154 Radio Frequency Range Selector (S1)



- **Blue Range 1:** 10.0 MHz to 5.5 MHz
- **Red Range 2:** 5.5 MHz to 3.0 MHz
- **Yellow Range 3:** 500 KHz to 200 KHz

T1154 Radio Transmitter Set Tuning Control (S5)

- **OFF:** Off
- **STD-BI:** Standby, receiver becomes operative.
- **TUNE:** low power continuous wave (CW) transmission occurs. Short distance communications and any setting up adjustments of the transmitter should be made with the switch at this position.
- **CW:** Continuous Wave. L.T. (Low Tension) energizing circuits of the two power units are maintained so that H.T. (High Tension) and L.T. continue to be supplied to transmitter and receiver.
- **MCW:** Modulated Continuous Wave. When key is pressed, oscillations from the tone-generator are fed to the suppressor grids of the power amplifiers, thus modulating their output at low frequency.
- **R/T:** Radio/Telephony. In this position, pressing the "T1154 Radio Morse Key" transmits navigator voice.

Notes:

- HF (High Frequency) transmission/reception is done with the fixed aerial (antenna). Frequency ranges 1 (blue) and 2 (red) are on HF frequencies.
- MF (Medium Frequency) transmission/reception is done with the trailing aerial (antenna). Frequency range 3 (yellow) is on MF frequencies.



Master Oscillator Dial

- Preset Channels S, T, U, V, W, X, & Y

**C17 Master Oscillating Tuning Condenser
Frequency Range 3 – Medium Frequency (M/F)**

- Preset Channels S, T, U, V, W, X, & Y

Master Oscillator Dial

- Preset Channels J, K, L, M, N, P, & Q

**C4 Master Oscillating Tuning Condenser
Frequency Range 2 – High Frequency (H/F)**

- Preset Channels J, K, L, M, N, P, & Q

Master Oscillator Dial

- Preset Channels A, B, C, D, E, F, & G

**C2 Master Oscillating Tuning Condenser
Frequency Range 1 – High Frequency (H/F)**

- Preset Channels A, B, C, D, E, F, & G

T1154 Radio Transmitter Magnetic Feed

T1154 Radio Transmitter Ammeter (Amperes)

Vernier Adjustment Switch

AERIAL AND ANODE TAPS MUST NOT BE ADJUSTED WITH KEY PRESSED

10 TO 5.5 Mc's		5.5 TO 3.0 Mc's		500 TO 200 Kc's	
A 9.255	J 5.250	S 444			
B 8.000	K 5.000	T 421			
C 7.710	L 4.750	U 303			
D 6.872	M 4.500	V 300			
E 5.955	N 4.250	W 270			
F 5.850	P 3.250	X 259			
G 5.750	Q 3.012	Y 250			

T1154 Radio Frequency Placard

Vernier Adjustment Switch

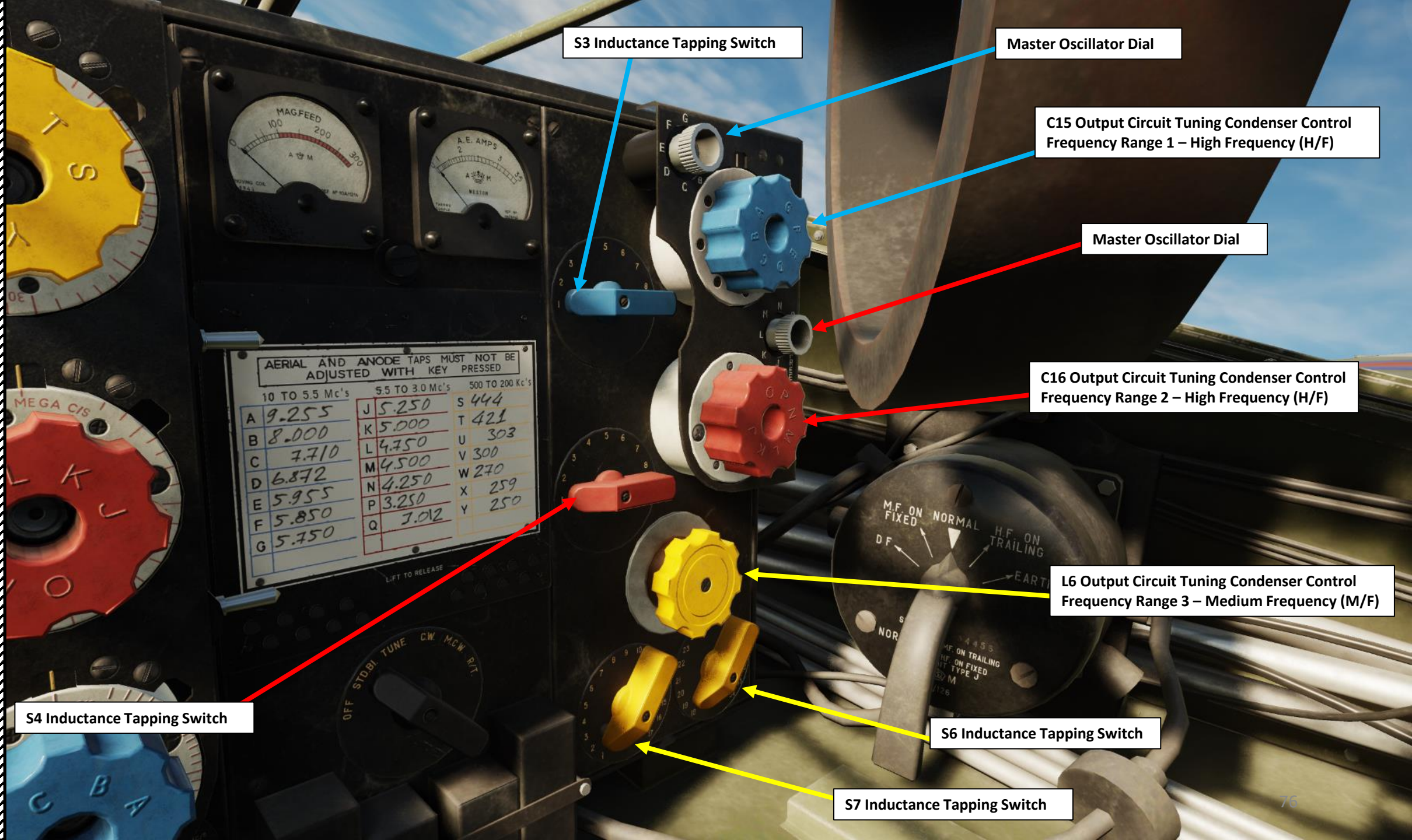

S3 Inductance Tapping Switch

Master Oscillator Dial

C15 Output Circuit Tuning Condenser Control
Frequency Range 1 – High Frequency (H/F)

Master Oscillator Dial

C16 Output Circuit Tuning Condenser Control
Frequency Range 2 – High Frequency (H/F)

L6 Output Circuit Tuning Condenser Control
Frequency Range 3 – Medium Frequency (M/F)

S6 Inductance Tapping Switch

S7 Inductance Tapping Switch

S4 Inductance Tapping Switch

AERIAL AND ANODE TAPS MUST NOT BE ADJUSTED WITH KEY PRESSED

10 TO 5.5 Mc's		5.5 TO 3.0 Mc's		500 TO 200 Kc's	
A	9.255	J	5.250	S	444
B	8.000	K	5.000	T	421
C	7.710	L	4.750	U	303
D	6.872	M	4.500	V	300
E	5.955	N	4.250	W	270
F	5.850	P	3.250	X	259
G	5.750	Q	3.012	Y	250

LIFT TO RELEASE



The **Inductance Tapping controls** are used to connect the aerial (antenna) to any of the output circuit inductances.

See this video for more information: <https://youtu.be/KSylo01n5FY>

The **Condenser controls** (also known as “variable capacitors”) are used to adjust radio transmitter frequencies. The oscillator frequency is also tuned when its associated condenser is being tuned.

See this video for more information: <https://youtu.be/adTdkM7Brss>

The **Oscillator controls** are used to stabilize radiated frequency of the condenser/capacitor.

See this video for more information: <https://youtu.be/yCwKB0Wvi-o>

The **Vernier controls** are used for frequency adjustment of +/- 1 %.

Inductance Tapping Switch

Output Tuning Condenser Control



AERIAL AND ANODE TAPS MUST NOT BE ADJUSTED WITH KEY PRESSED

10 TO 5.5 Mc's	5.5 TO 3.0 Mc's	300 TO 200 Kc's
A 9.255	J 5.250	S 444
B 8.000	K 5.000	T 421
C 7.710	L 4.750	U 303
D 6.872	M 4.500	V 300
E 5.955	N 4.250	W 270
F 5.850	P 3.250	X 259
G 5.750	Q 3.002	Y 250

Master Oscillator Dial

Master Oscillating Tuning Condenser

Vernier Adjustment Switch

THE TAPS MUST NOT BE
WITH KEY PRESSED

	TO 3.0 Mc's	500 TO 200 Kc's
250	S 444	
300	T 421	
350	U 303	
400	V 300	
450	W 270	
500	X 259	
550	Y 250	

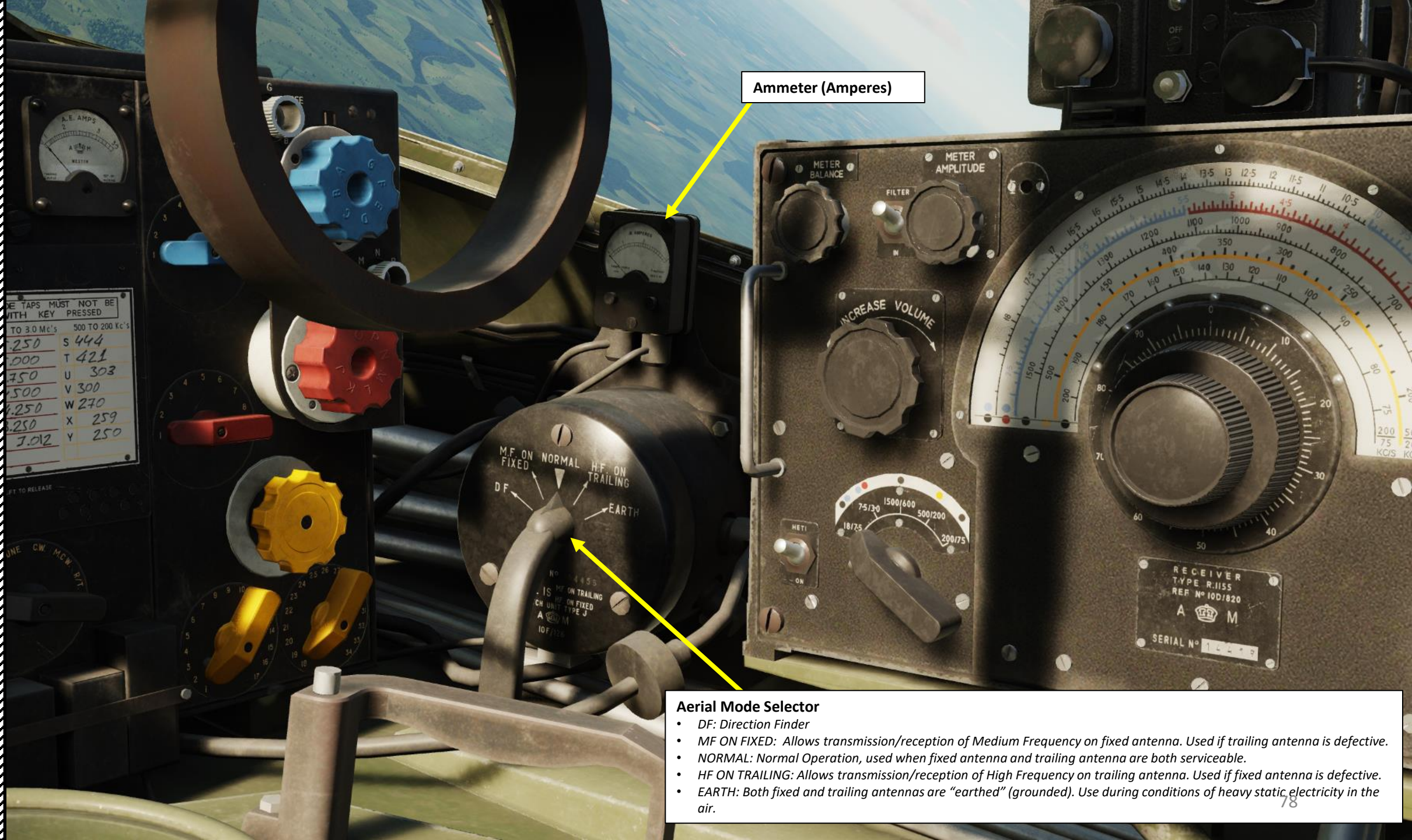

Ammeter (Amperes)

Aerial Mode Selector

- *DF*: Direction Finder
- *MF ON FIXED*: Allows transmission/reception of Medium Frequency on fixed antenna. Used if trailing antenna is defective.
- *NORMAL*: Normal Operation, used when fixed antenna and trailing antenna are both serviceable.
- *HF ON TRAILING*: Allows transmission/reception of High Frequency on trailing antenna. Used if fixed antenna is defective.
- *EARTH*: Both fixed and trailing antennas are "earthed" (grounded). Use during conditions of heavy static electricity in the air.



Flashlight

- ON/OFF: LALT + L

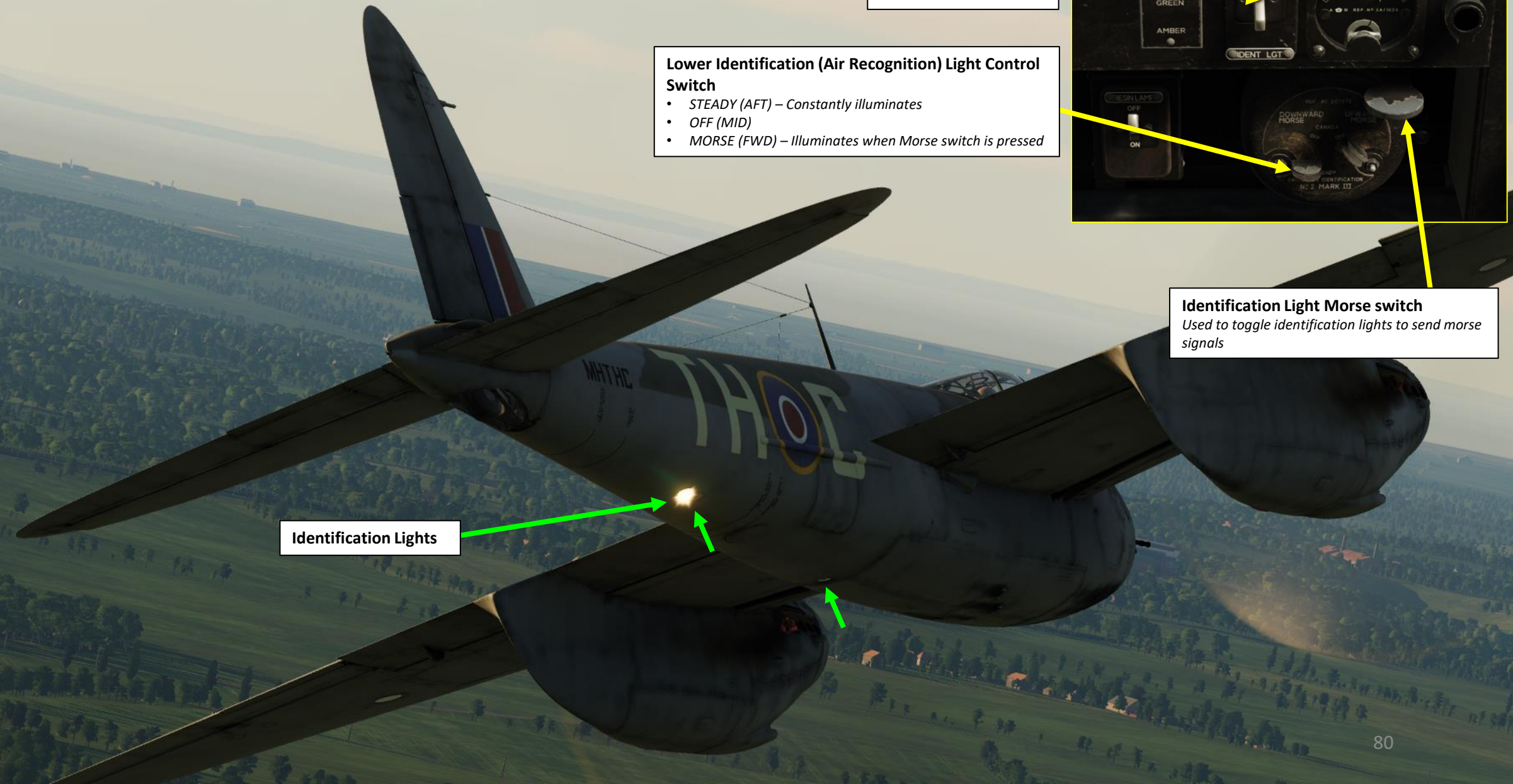

Identification Lights

**Identification Lights
Color Selector Switch**

- UP: Red
- MIDDLE: Green
- DOWN: Amber

Lower Identification (Air Recognition) Light Control Switch

- STEADY (AFT) – Constantly illuminates
- OFF (MID)
- MORSE (FWD) – Illuminates when Morse switch is pressed



Identification Light Morse switch
Used to toggle identification lights to send morse signals

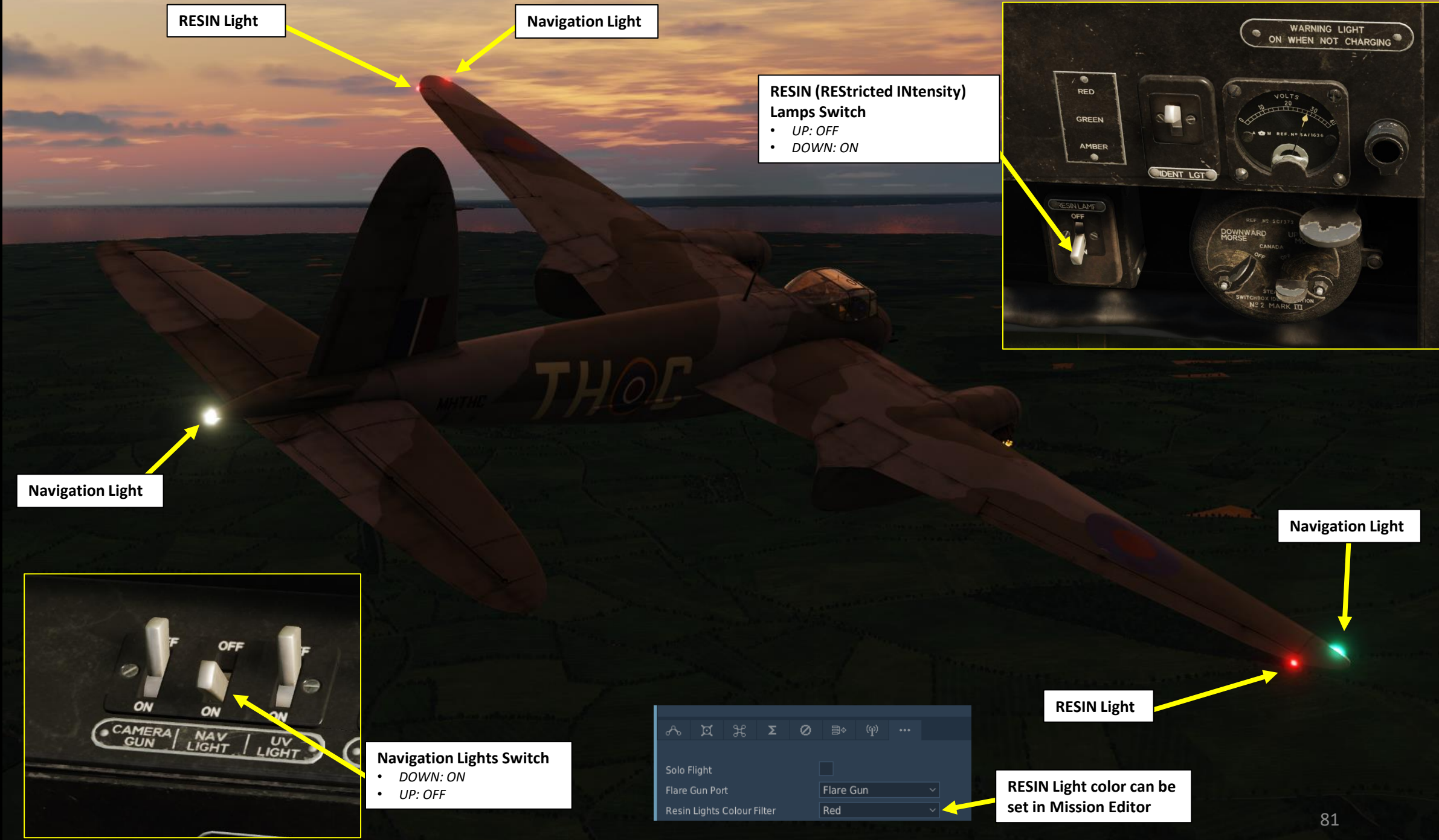

RESIN Light

Navigation Light

RESIN (REstricted INTensity) Lamps Switch
• UP: OFF
• DOWN: ON



Navigation Light

Navigation Light

RESIN Light

RESIN Light color can be set in Mission Editor



Navigation Lights Switch
• DOWN: ON
• UP: OFF

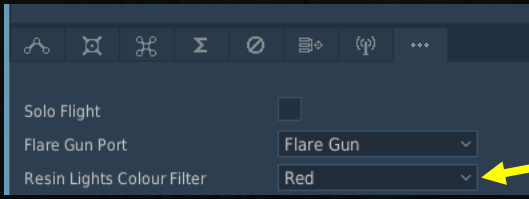



DH.98 MOSQUITO
FB MK VI

PART 3 - COCKPIT & EQUIPMENT



Landing Light

Landing Light

Starboard (Right) Landing Light Control Rheostat

Portside (Left) Landing Light Control Rheostat



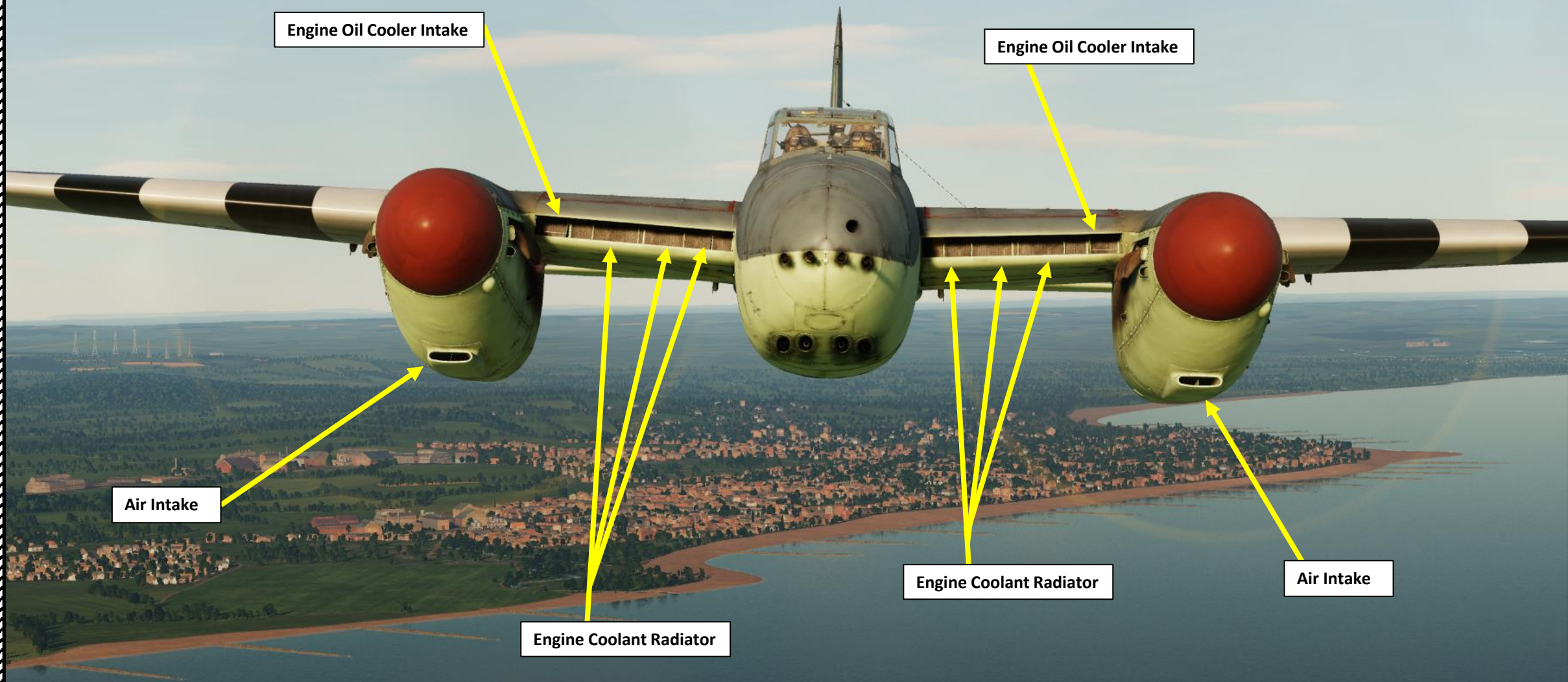

Engine Oil Cooler Intake

Engine Oil Cooler Intake

Air Intake

Engine Coolant Radiator

Engine Coolant Radiator

Air Intake



Radiator Flap
Pneumatically actuated

Radiator Flap
Pneumatically actuated



DH.98 MOSQUITO
FB MK VI

PART 3 – COCKPIT & EQUIPMENT



Pitot Tube



DH.98 MOSQUITO
FB MK VI

PART 3 – COCKPIT & EQUIPMENT

Radio Aerial (Antenna) Mast

Radio Aerials (Antennas)

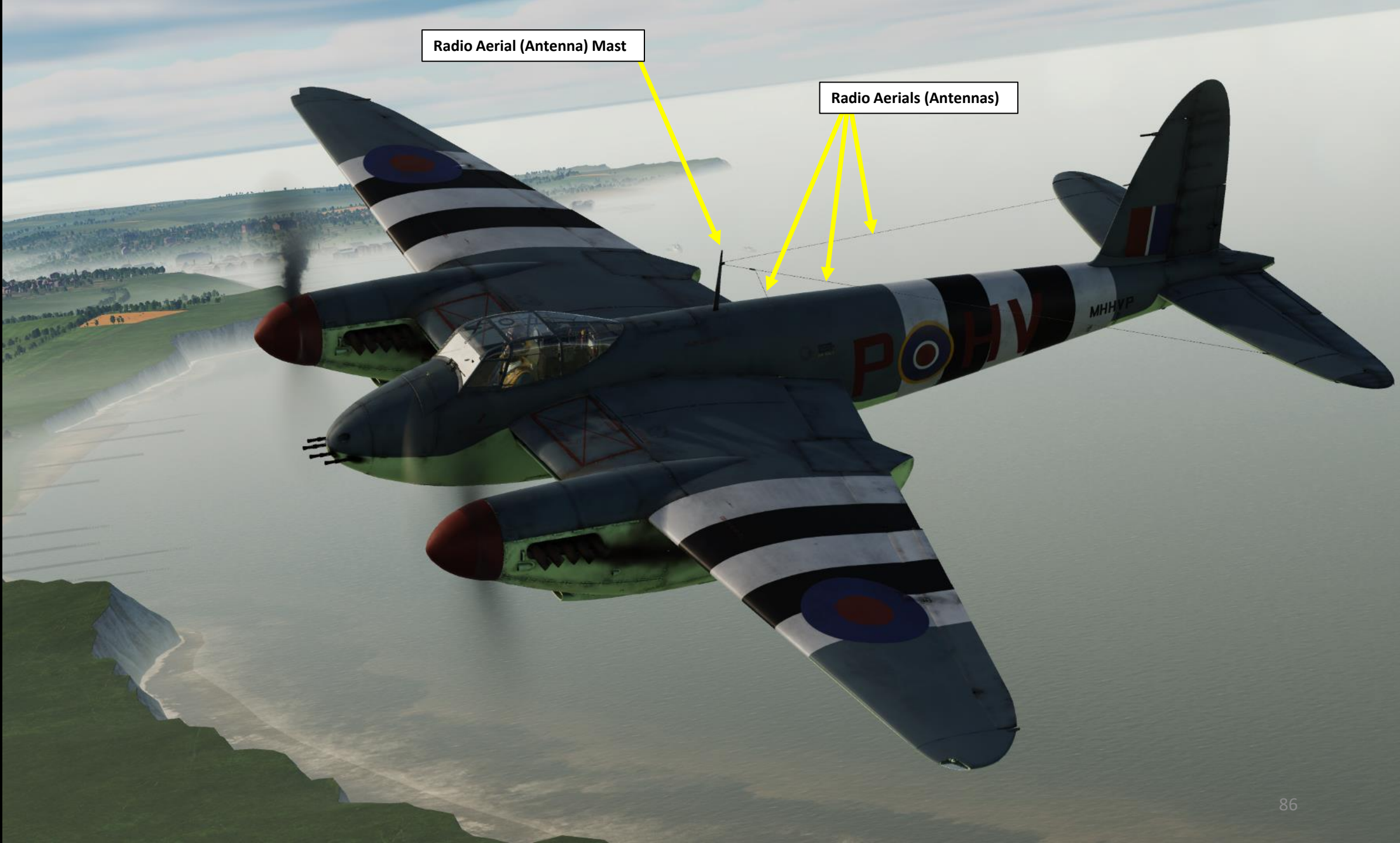



DH.98 MOSQUITO
FB MK VI

PART 3 – COCKPIT & EQUIPMENT



Tailwheel



Mudguard



Wheel Brakes
Pneumatically actuated



Landing Gear (shown deployed)
Hydraulically actuated by engine-driven pumps





DH.98 MOSQUITO
FB MK VI

PART 3 – COCKPIT & EQUIPMENT



Flaps

Hydraulically actuated, from 0 to 45 deg

Gun Camera (Cine-Camera)

4 x Browning Machine-Guns (0.303 in)

4 x Mk II Hispano Cannon (20 mm)

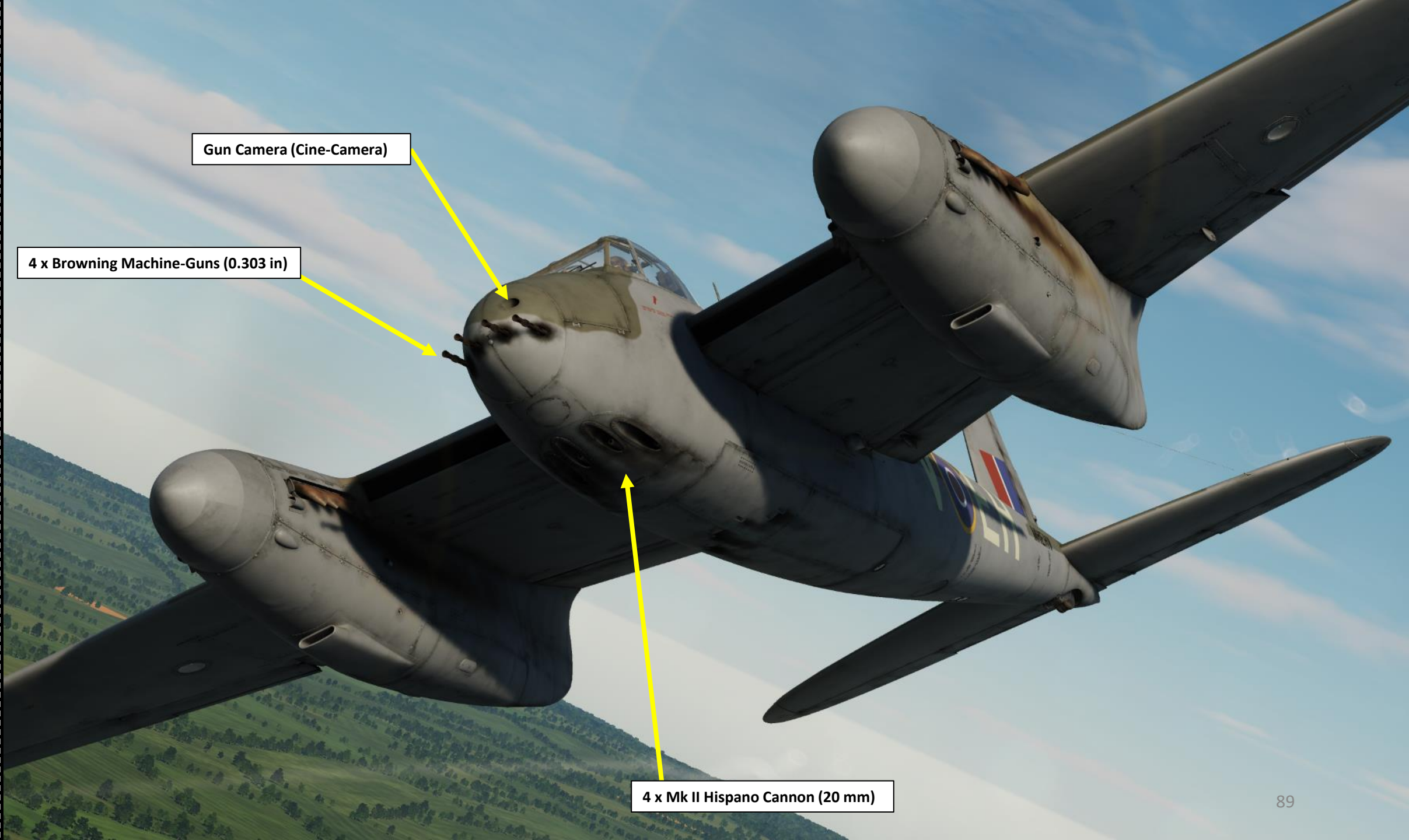



DH.98 MOSQUITO
FB MK VI

PART 3 - COCKPIT & EQUIPMENT



2 x Bombs
250 lbs or 500 lbs each

Bomb Bay Doors (Open)
Hydraulically actuated



PART 3 – COCKPIT & EQUIPMENT



Ammunition Ejection Ports

Access to 20 mm Hispano Cannons



DH.98 MOSQUITO
FB MK VI

PART 3 – COCKPIT & EQUIPMENT

Rudder Trim Tab



Elevator Trim Tab





DH.98 MOSQUITO
FB MK VI

PART 3 – COCKPIT & EQUIPMENT



Aileron Trim Tab



DH.98 MOSQUITO
FB MK VI

PART 3 – COCKPIT & EQUIPMENT



Ground Power
Socket (24 Volts)



Engine Fuel Primer Handle (inside wheel well)

Priming the engines had to be done by a ground crew. Some variants of the Mosquito had external trap doors to access the pump, but that left the ground crew very exposed to the propeller and engine exhaust. The Mosquito variant we have in DCS has its primer pump located inside the wheel well, which was more cramped but a little bit safer.

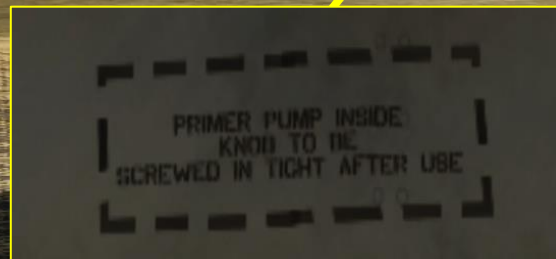



DH.98 MOSQUITO
FB MK VI

PART 3 – COCKPIT & EQUIPMENT

In World War 2, the Royal Air Force used aircraft markings as identification codes. For instance, “UP-G” means that the Aircraft G belongs to No. 605 Squadron (UP). You can set up your aircraft markings in the Mission Editor.

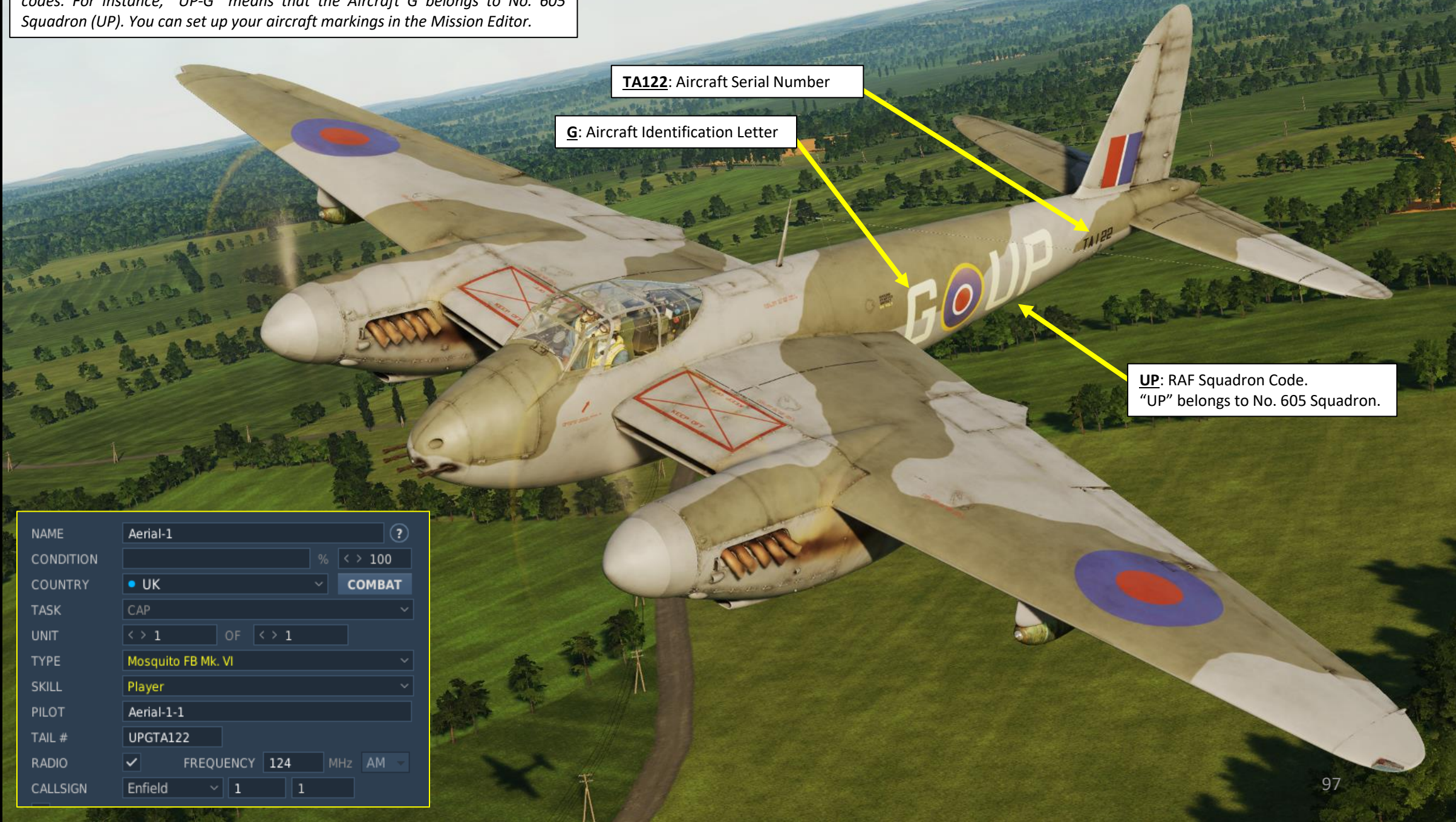

TA122: Aircraft Serial Number

G: Aircraft Identification Letter

UP: RAF Squadron Code.
“UP” belongs to No. 605 Squadron.

NAME	Aerial-1	?
CONDITION		% < > 100
COUNTRY	UK	COMBAT
TASK	CAP	
UNIT	< > 1	OF < > 1
TYPE	Mosquito FB Mk. VI	
SKILL	Player	
PILOT	Aerial-1-1	
TAIL #	UPGTA122	
RADIO	<input checked="" type="checkbox"/>	FREQUENCY 124 MHz AM
CALLSIGN	Enfield	1 1



DH.98 MOSQUITO
FB MK VI

PART 4 - START-UP

PRE-START



PRE-START

1. Close Side Door by clicking on the door handle.
 - Close Door: LCTRL+C
 - Open Door: LSHIFT+C

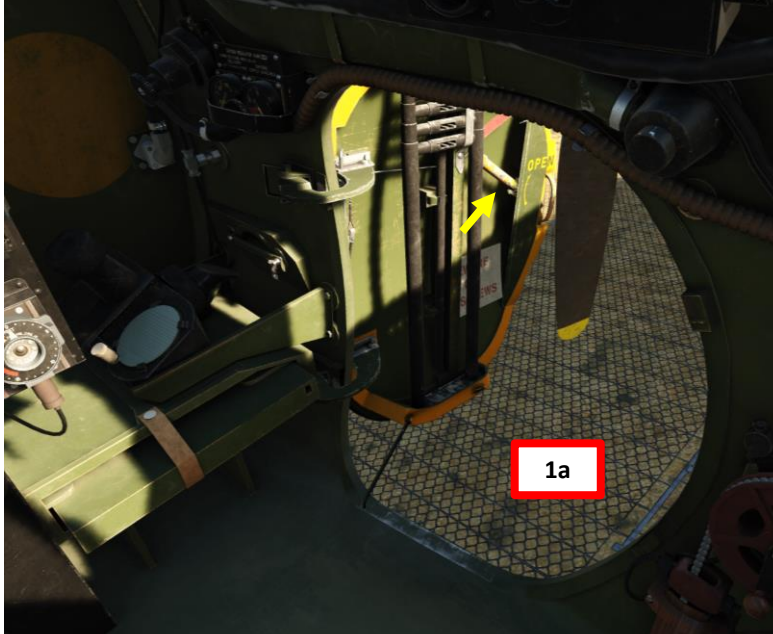

PRE-START

2. Engage Parking Brake
 - a) Press and hold Wheel Brake Lever
 - b) While brake lever is pressed, press the Wheel Brake Locking Pin IN (LALT+T).
 - c) Release Wheel Brake Lever. Wheel Brake Lever should remain locked in Parked position.
 - d) Release Locking Pin (LALT+T)
3. Pneumatic Supply Pressure – Check no less than 200 psi

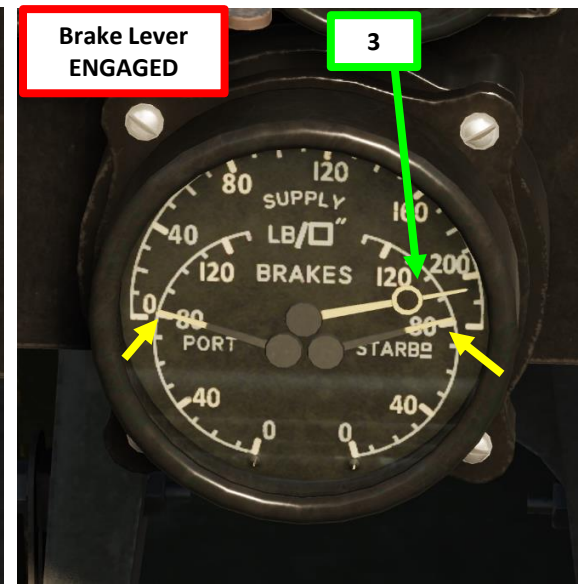
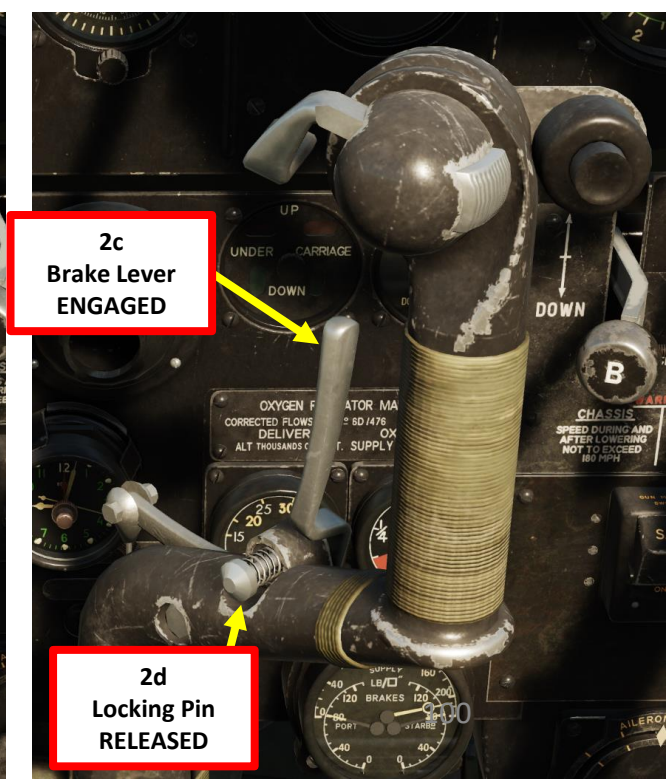
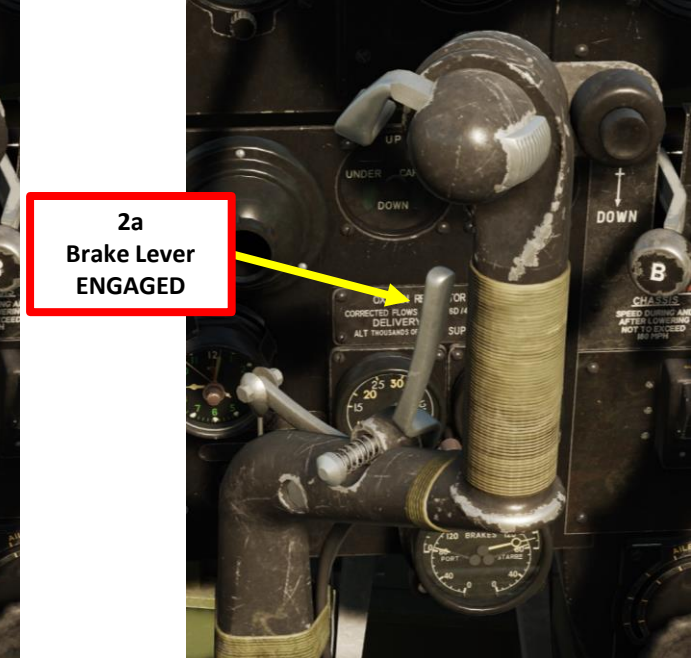
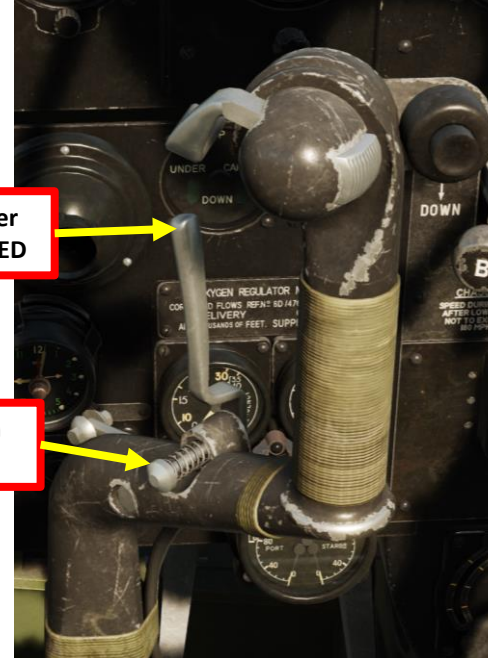

2b Locking Pin IN (ON)

2d Locking Pin RELEASED

PRE-START

- If operating at night, turn on your flashlight.
 - Binding: LALT+L
- Set Electrical Services Master (Battery) Switch – ON (UP)
- Voltmeter – Check no less than 24 V
- Check Magneto Ignition Switches – OFF



PRE-START

8. Ensure elevator, aileron and rudder controls are working by moving stick and rudder pedals
9. Set Bomb Doors – Shut (Selector NEUTRAL)
10. Flip Bomb Bay Light Switch Cover UP. Confirm that Bomb Bay Light is EXTINGUISHED, which means that the bomb doors are closed.
11. Check that Bomb Selector Panel switches are all OFF (UP)
12. Scroll mousewheel on the “Altimeter Barometric Pressure Setting” knob to adjust the altimeter needle to 0.

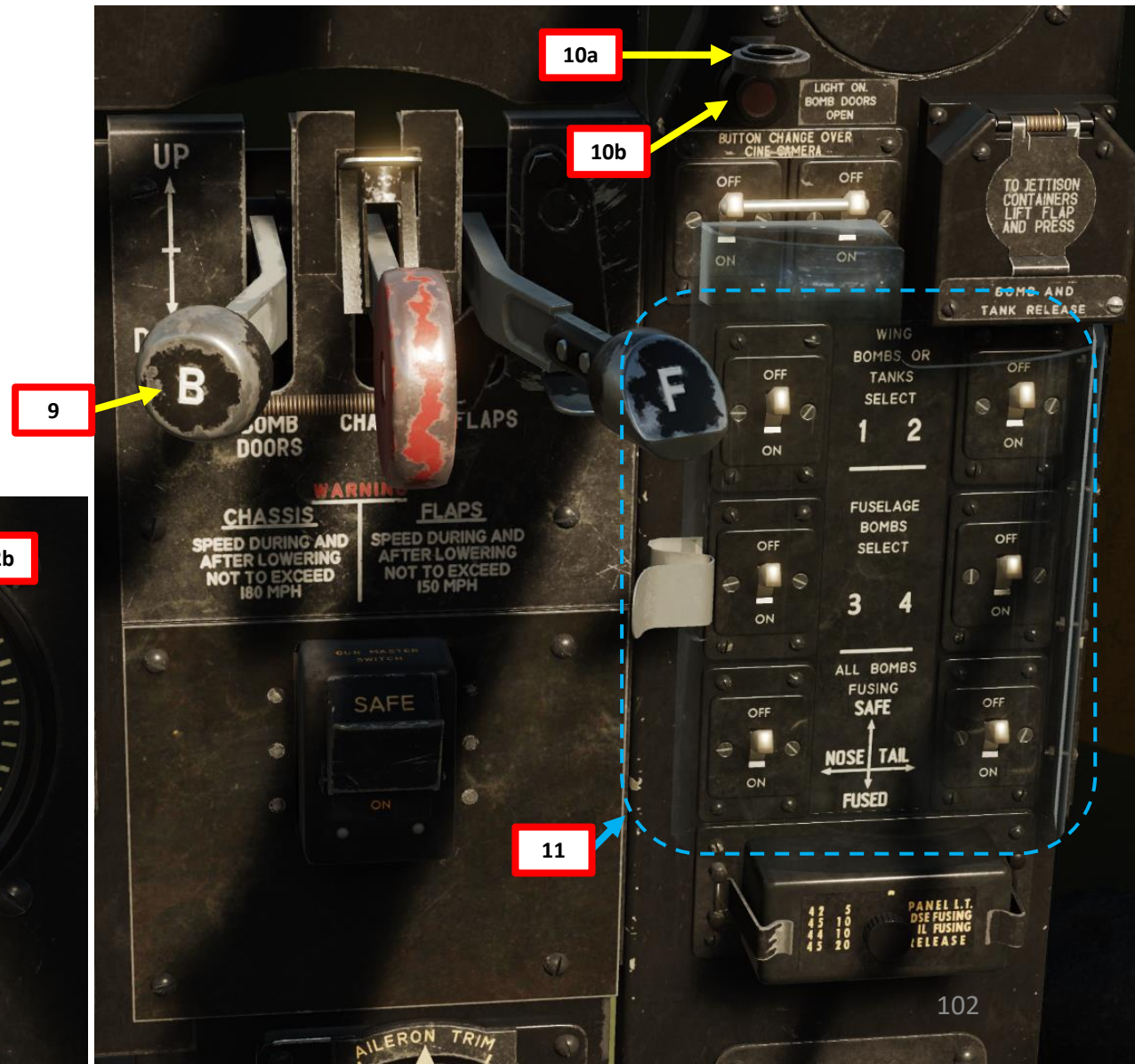
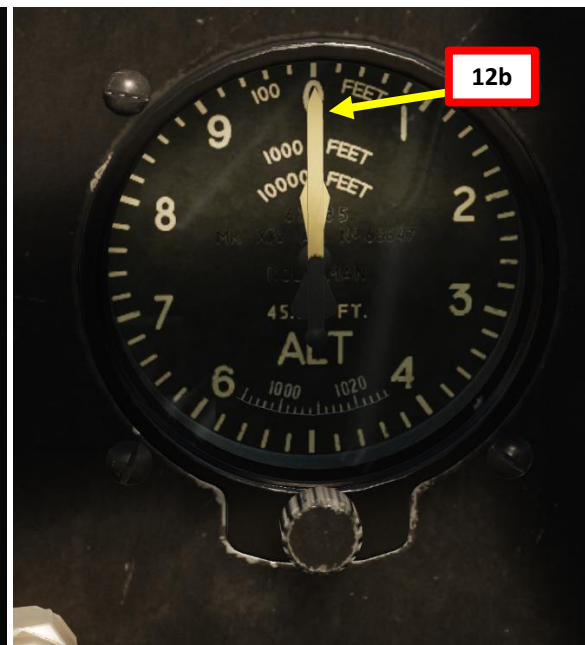
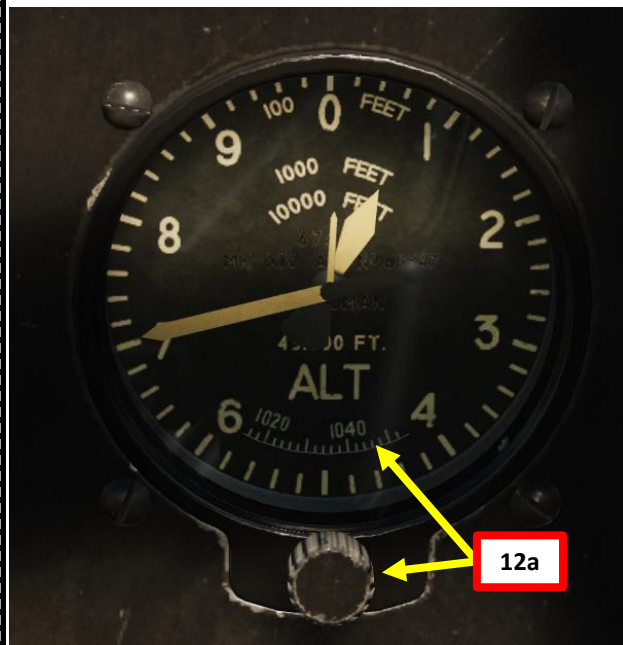

ENGINE START

1. Set Main Fuel Cocks – Outer Tanks
2. Set Engine Fuel Cut-Out Handles – IN (Fuel Valve Open)
3. Set Pressure Venting Cock – ON (Vertical)
4. Set Fuel Transfer Cock – OFF (Vertical)
5. Set Immersed Fuel Pump Switch – OFF
6. Set Radiator Shutters Switches – OFF/CLOSED (UP)

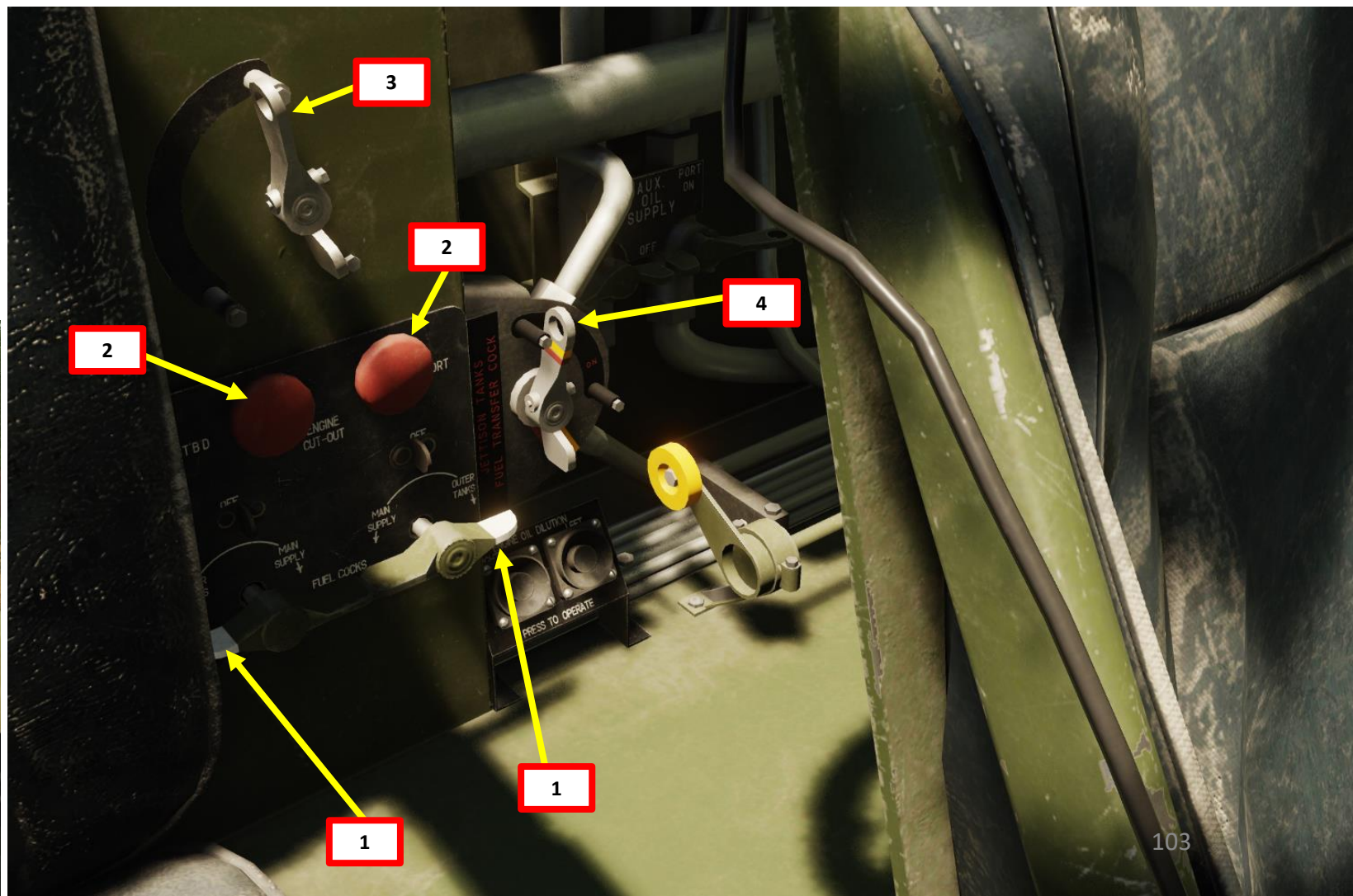
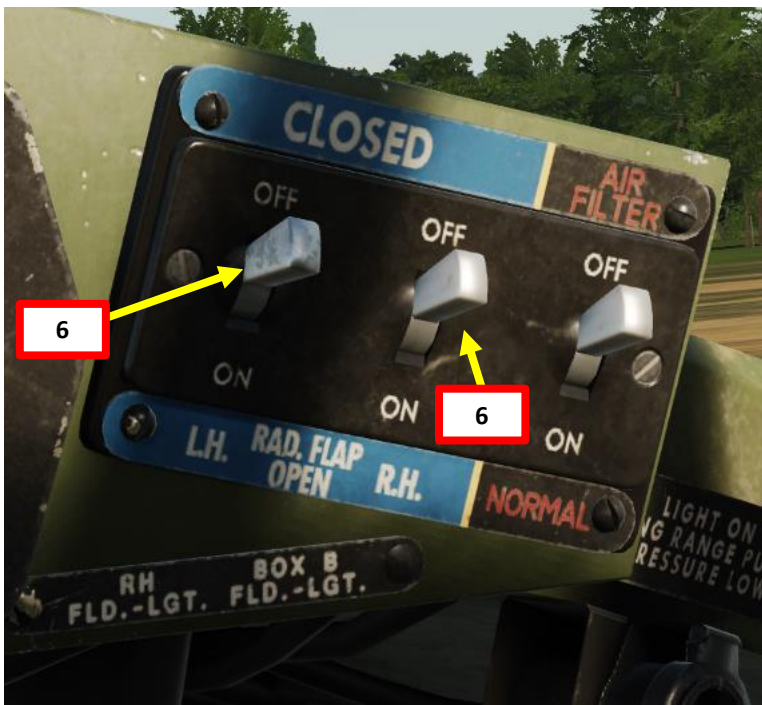



ENGINE START

7. Set Throttles – 0.5 inch OPEN (FORWARD)
8. Set RPM Control Levers – Maximum RPM Position (FULLY FORWARD)
9. Set Supercharger Switch – Moderate / Lower Gear (DOWN)
10. Set Fuel Mixture Lever – RICH (DOWN)

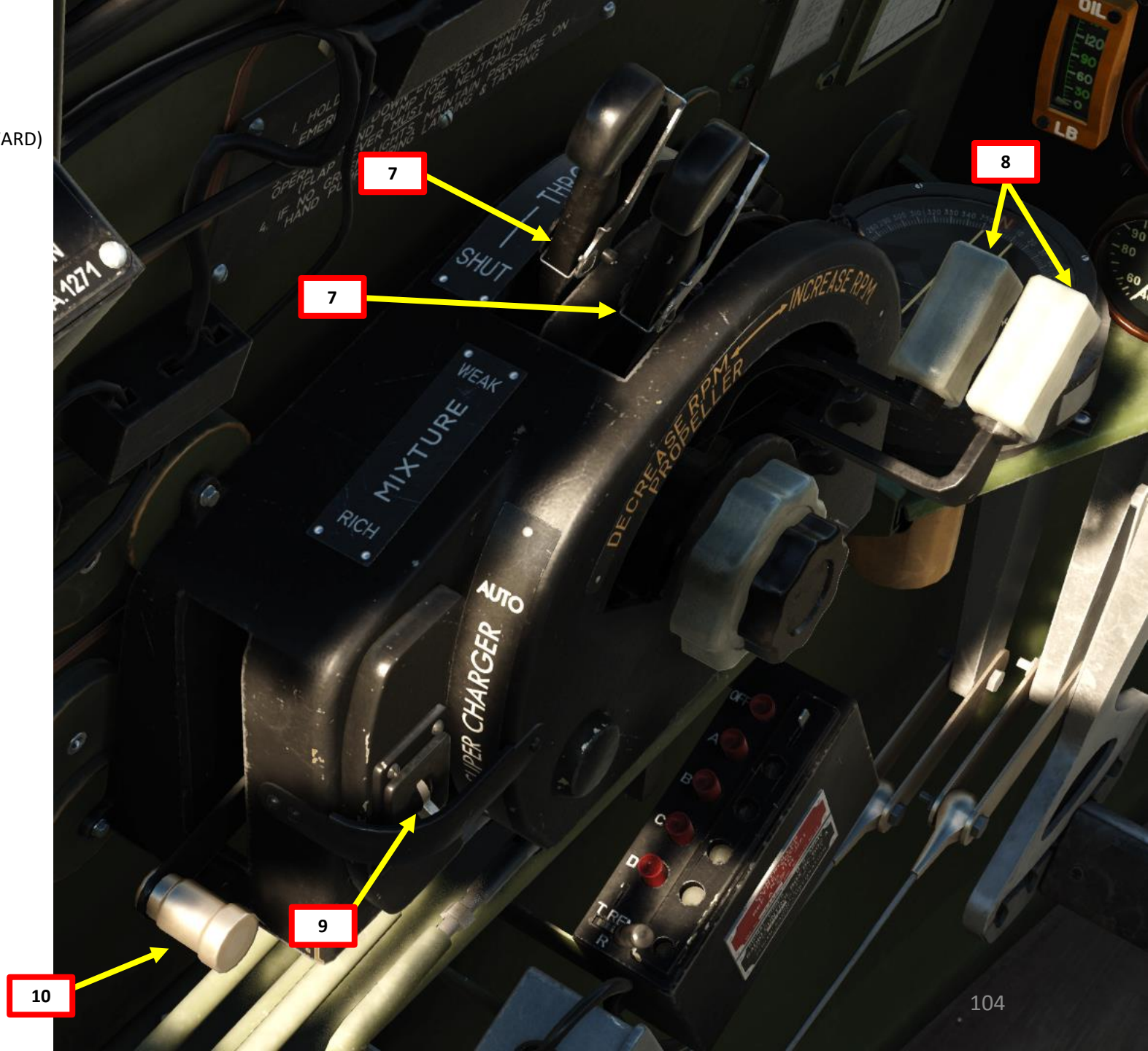

ENGINE START

11. Open side window
12. Contact ground crew to start priming the engines. The fuel priming pump is located inside the wheel well.
 - a) Press "RALT + \\" (Communication Push-to-Talk)
 - b) Select ground crew by pressing "F8"
 - c) Select "Start Priming Engines" by pressing "F6".

Main 12a
 F1. Wingman...
 F2. Flight...
 F3. Second Element...
 F5. ATC...
 F8. Ground Crew... 12b
 F12. Exit

2. Main. Ground Crew
 F1. Rearm & Refuel
 F2. Ground Electric Power...
 F3. Request Repair
 F4. Wheel chocks...
 F5. Change cabin equipment...
 F6. Start priming engines 12c
 F11. Previous Menu
 F12. Exit

12d **PLAYER:** start priming engines **Ground Crew:** copy



12d Ground Crew priming the engine

ENGINE START

13. Set Left/Port Engine Magneto Ignition No. 1 & No. 2 Switches – ON (UP)
14. Flip Left/Port Engine Starter and Booster Coil Covers – UP.
 - Note: In real life, these spring-loaded caps provide protection against accidental pressing.
 - Fun fact: the Merlin 25 uses an electrical starter, which relies on battery power (or external ground power) to start the propeller.
15. Verify that the propeller is clear and command « Clear port prop! » to warn people around you that you are about to start the left engine.
16. Press and Hold (Left Click) Left/Port Engine Starter Button. Allow the propeller blades to turn 3 to 4 rotations while the ground crew works the priming pump.
17. While Engine Starter Button is pressed, press and hold (Right Click) the Left/Port Engine Booster Coil Button until the engine “catches” and motor ignition occurs.
 - Note: do not hold the Starter & Booster Coil buttons for more than 20 seconds.
18. Once the engine is running, adjust left throttle to set the engine RPM to 1200.

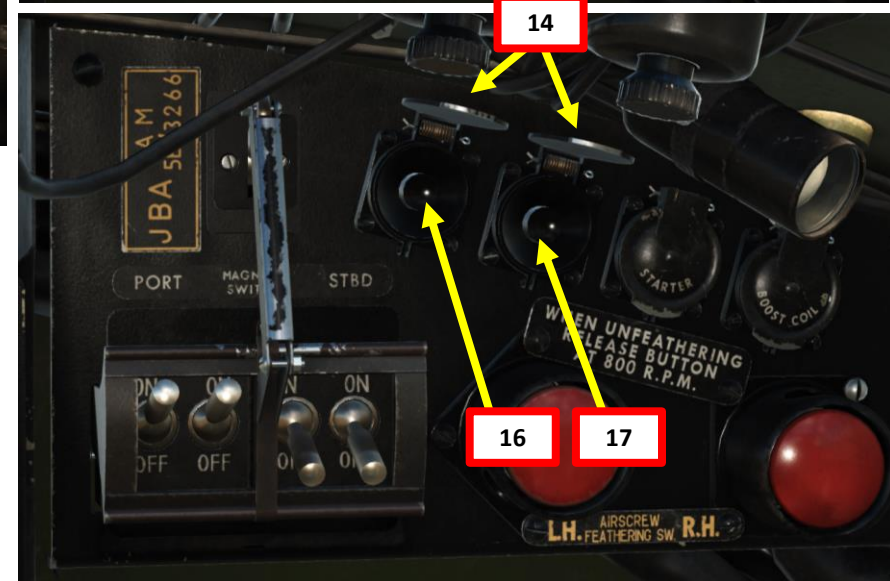

ENGINE START

19. Set Right/Starboard Engine Magneto Ignition No. 1 & No. 2 Switches – ON (UP)
20. Flip Right/Starboard Engine Starter and Booster Coil Covers – UP
21. Verify that the propeller is clear and command « Clear starboard prop! » to warn people around you that you are about to start the right engine.
22. Press and Hold (Left Click) Right/Starboard Engine Starter Button. Allow the propeller blades to turn 3 to 4 rotations while the ground crew works the priming pump.
23. While Engine Starter Button is pressed, press and hold (Right Click) the Right/Starboard Engine Booster Coil Button until the engine “catches” and motor ignition occurs.
 - Note: do not hold the Starter & Booster Coil buttons for more than 20 seconds.
24. Once the engine is running, adjust right throttle to set the engine RPM to 1200.

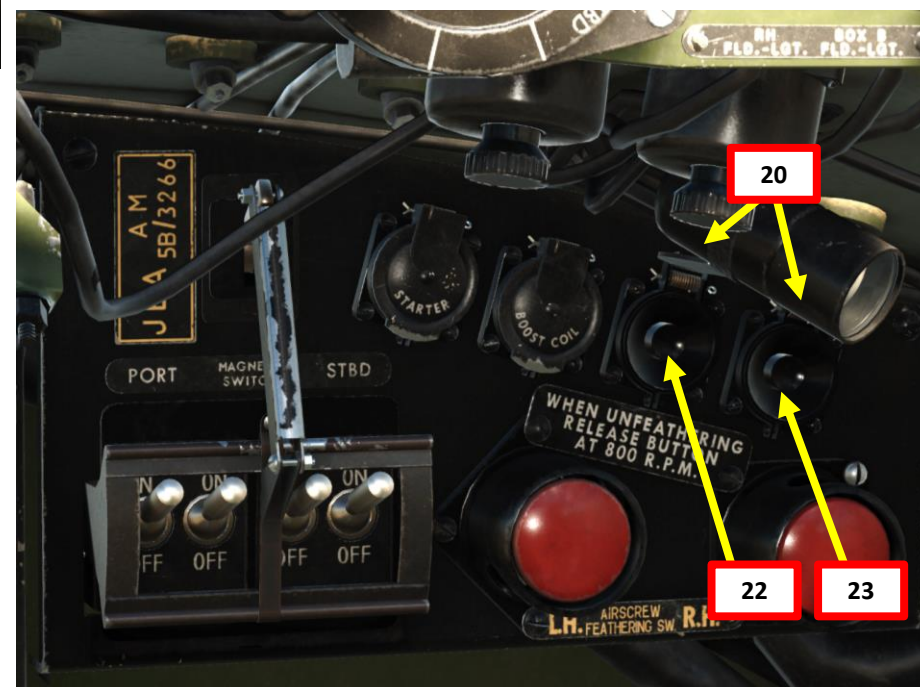

ENGINE START

25. Flip all starter and booster coil covers DOWN
26. Set Radiator Shutters Switches – ON/OPEN (DOWN)
27. If operating in dusty conditions or from a dirt runway, set Carburettor Air Intake Filter Switch – ON (DOWN).
If using a paved or prepared surface, leave to OFF (UP).
28. Confirm that Generator Warning Light is Extinguished
29. Set Immersed Fuel Pump Switch – ON if using Long-Range Fuselage Fuel Tank. Otherwise, leave to OFF.

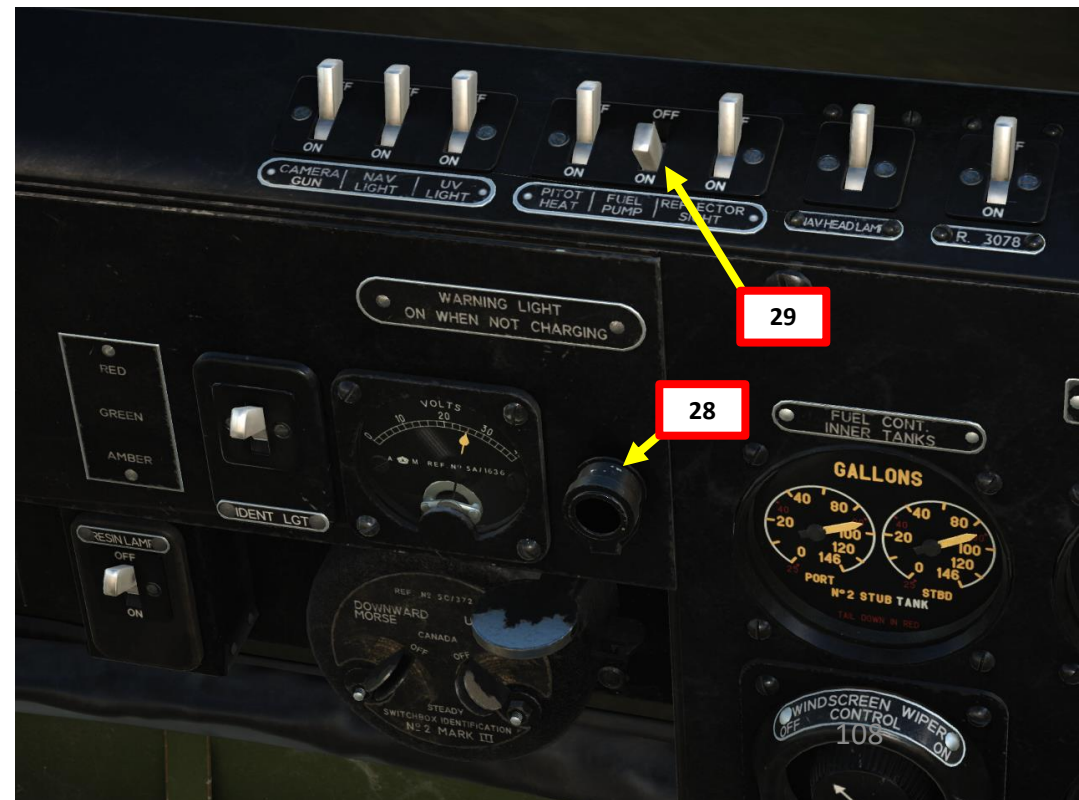
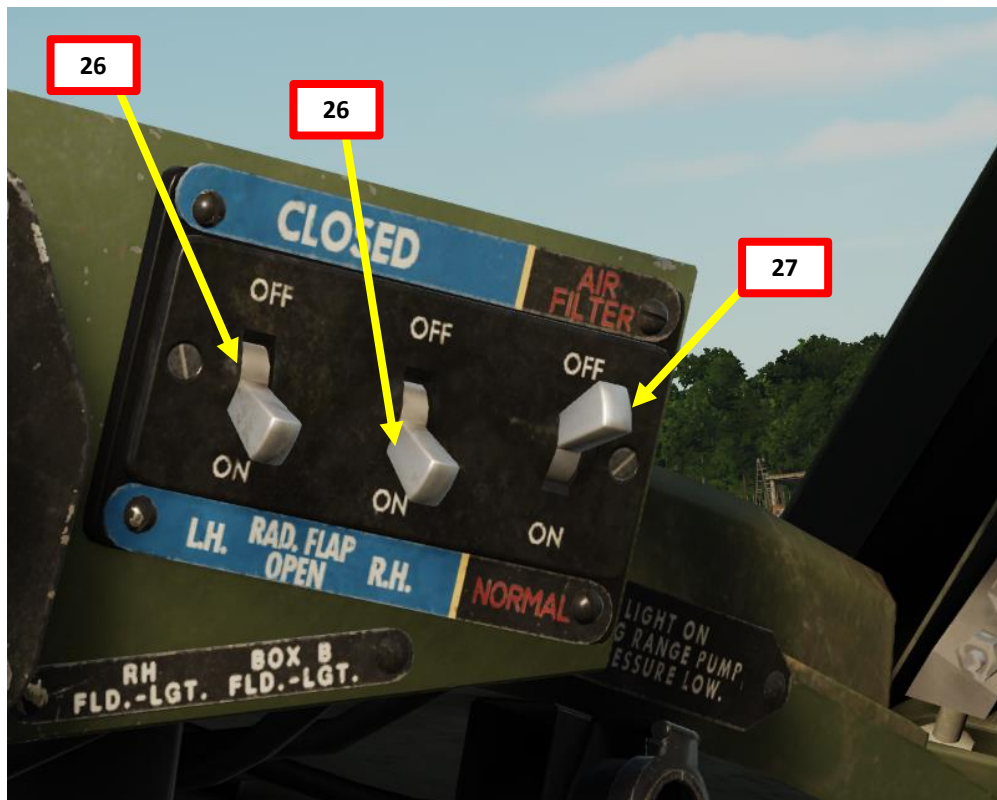
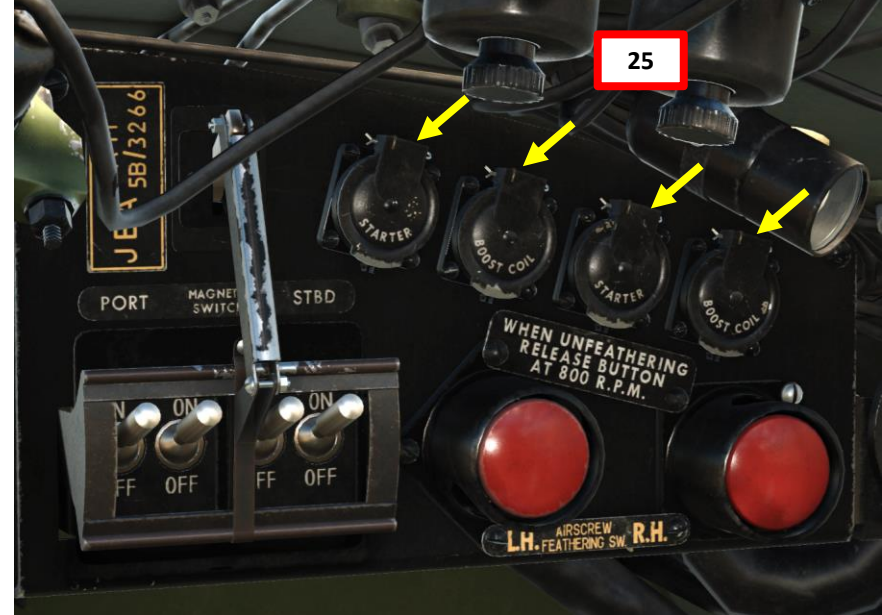

POST-START

30. Set Pilot Oxygen Valve – OPEN
31. Set the radio Transmit-Receive switch to “REM” (Remote Operation)
32. Select desired channel (A, B, C or D)
33. Adjust Radio Volume – As Required
34. Set Remote Indicating (R.I.) Compass Power Switches – ON (DOWN)

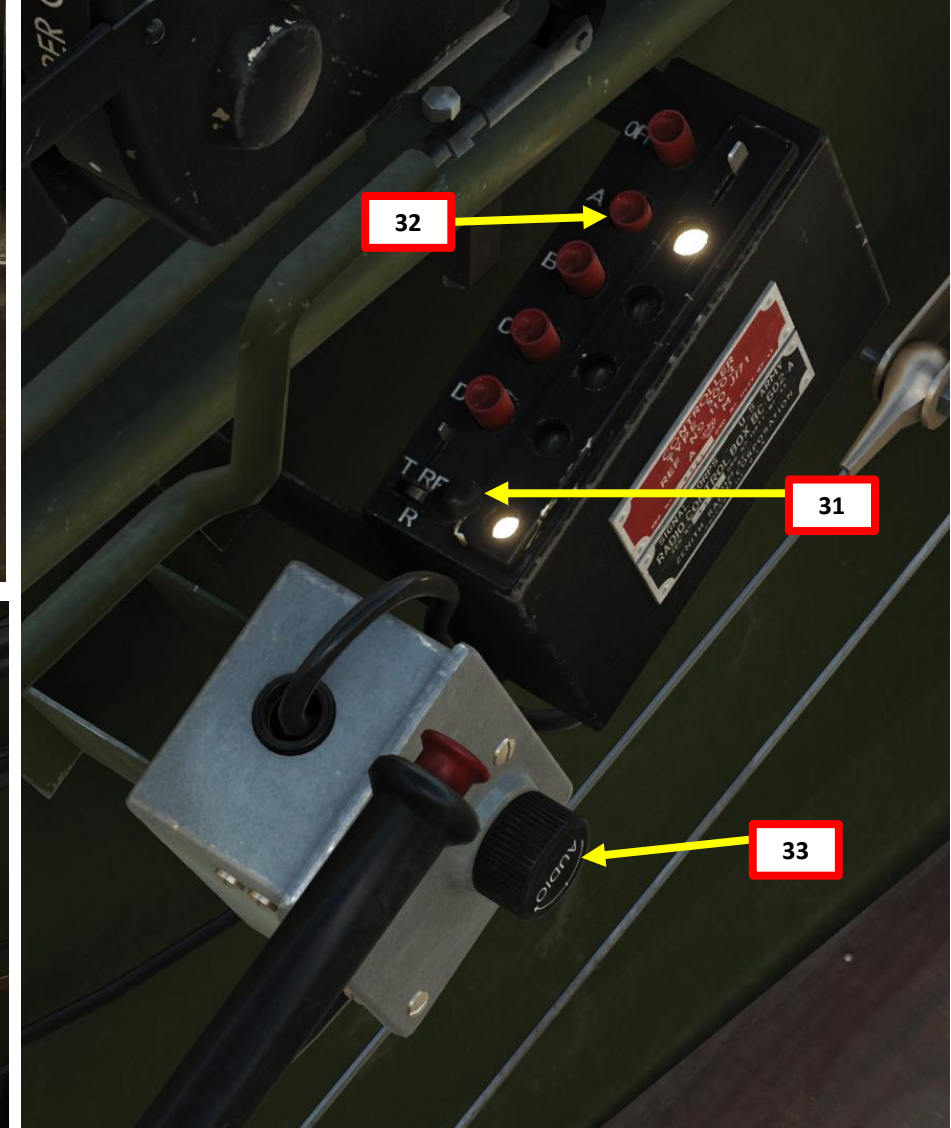
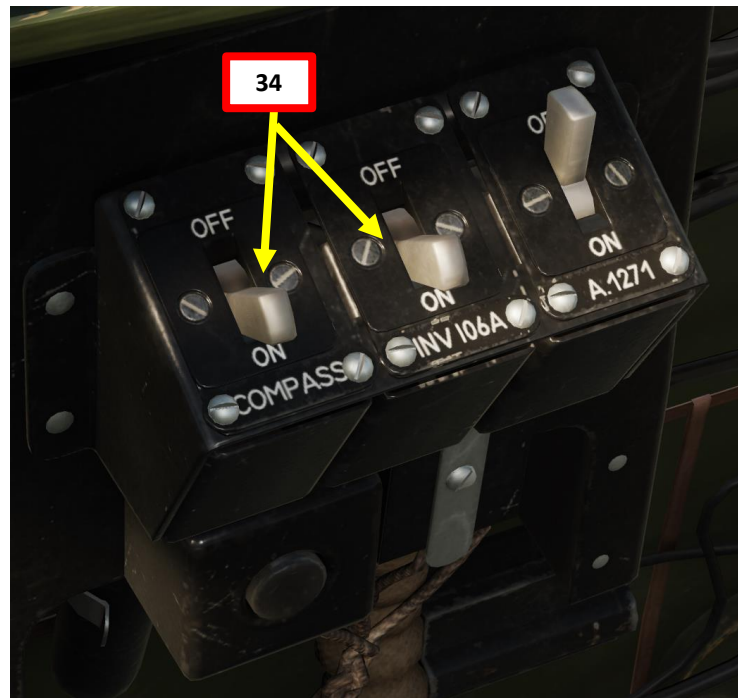
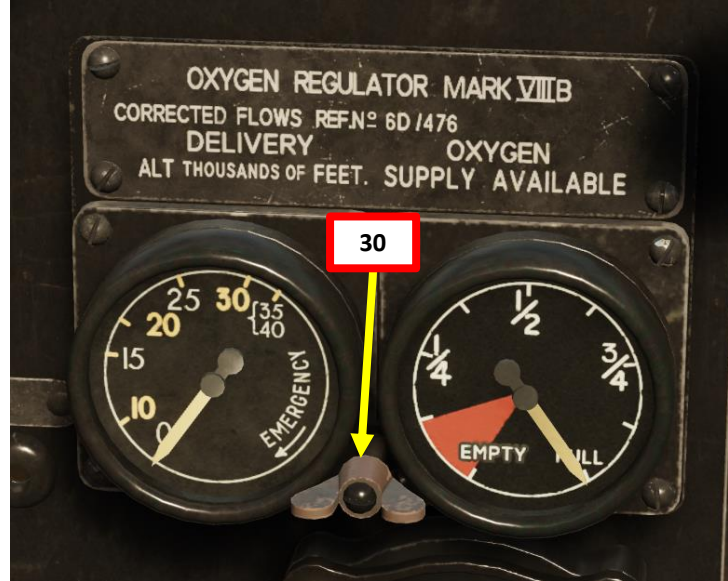

POST-START

35. Turn the Course Setter ring of the P8 Magnetic Compass (scroll mousewheel on course setter ring) to align the red “N” (North Reference of the course setter) with the white “T” cross (real magnetic North of the compass). The lubber line will display your current heading.
36. Turn the Directional Gyro adjustment knob to match the heading of the directional gyro with the one shown by the magnetic compass’ lubber line.

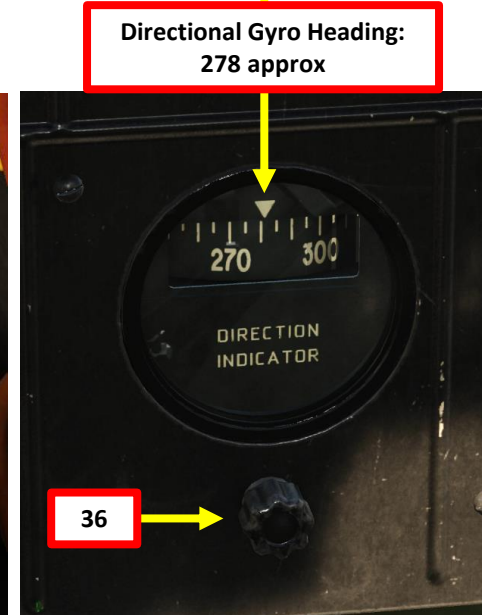
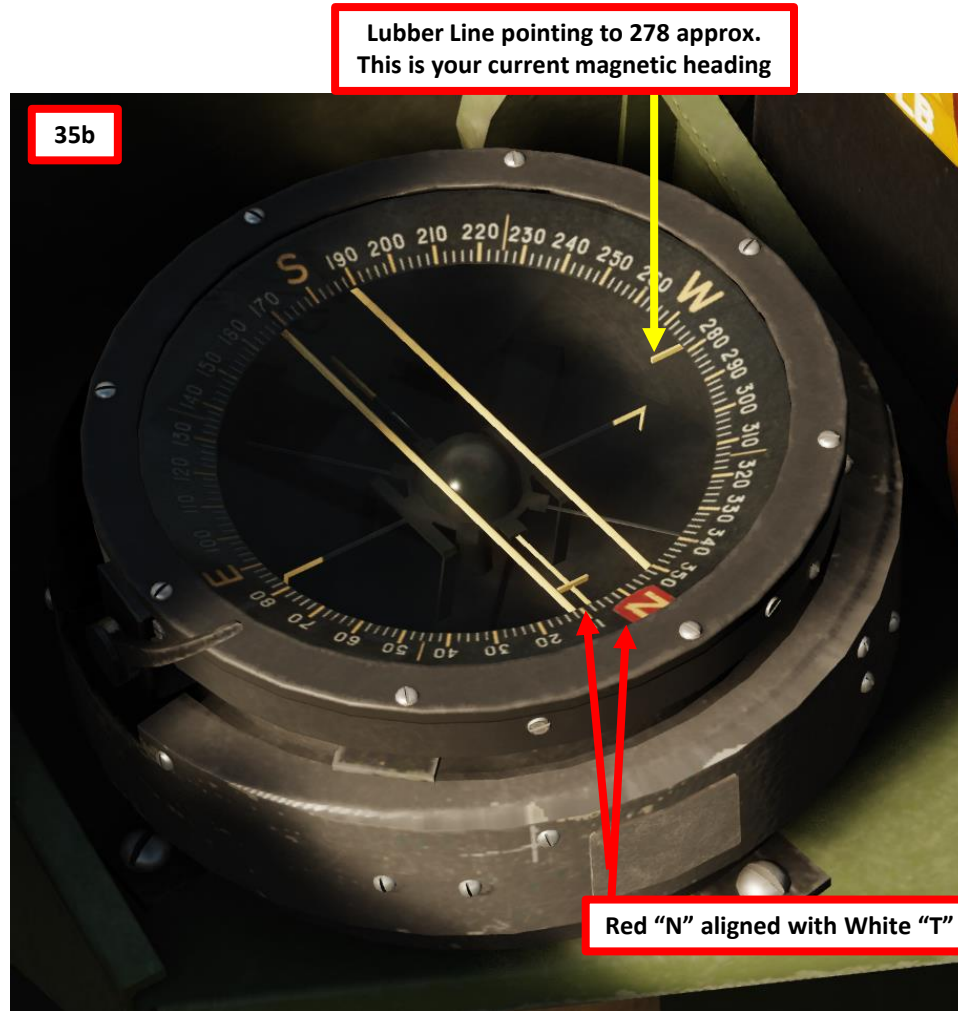
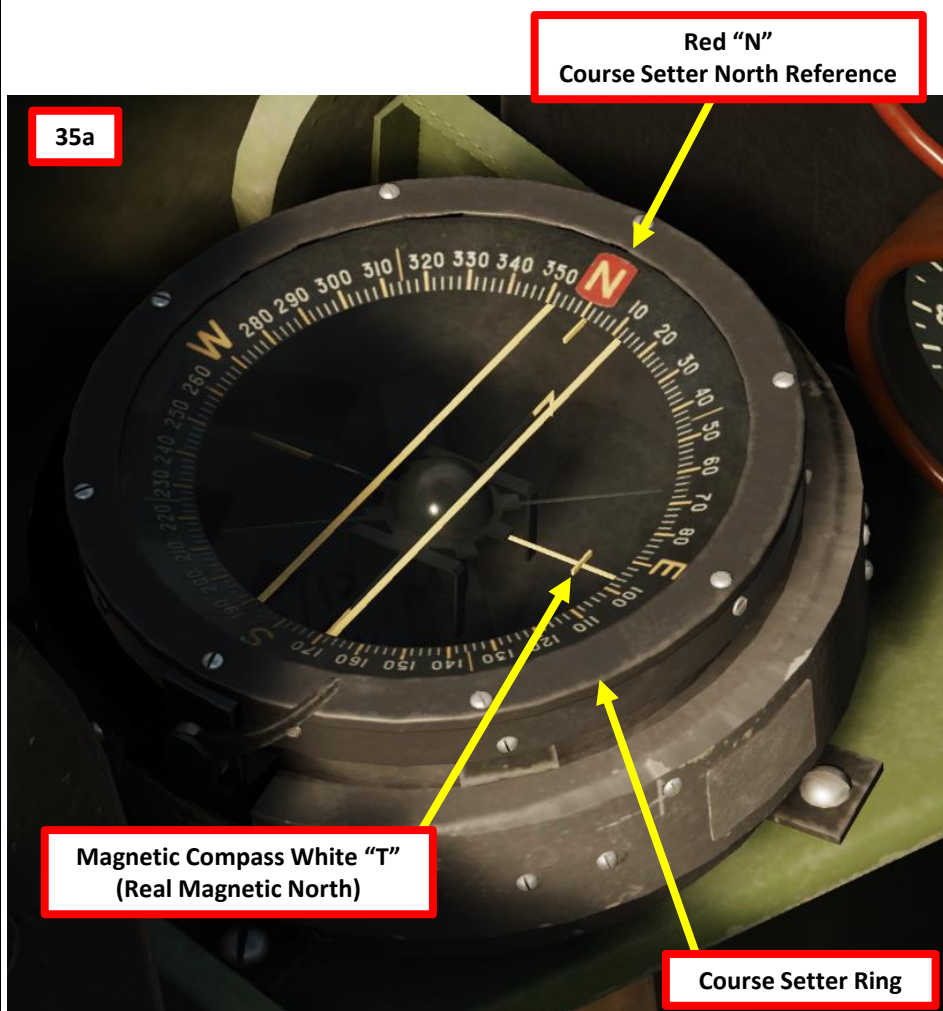

POST-START

- Note: to access some of the switches on the right hand side, select Navigator Seat by pressing “2”
 - 37. Check Oxygen High Pressure Valve – OPEN (turn valve clockwise)
 - 38. Set Navigation Lights – As Required
 - 39. Set Pitot Heat Switch – ON (if required)
 - 40. Set Gun Reflector Sight Power Switch – ON (DOWN)
 - 41. Set Cine-Camera (Gun Camera) Master Switch – ON (DOWN)
 - 42. Set R3078 IFF (Identify-Friend-or-Foe) Transceiver Power Switch – ON (DOWN)
 - 43. Set T1154 Radio Transmitter Low Voltage Power Switch – ON (LEFT)
 - 44. Set T1154 Radio Transmitter High Voltage Power Switch – ON (LEFT)
 - 45. Set Transmitter Type F Power Switch – ON (AFT)
- Note: this step is optional since the Type F infrared beam transmitter is not simulated in DCS yet.

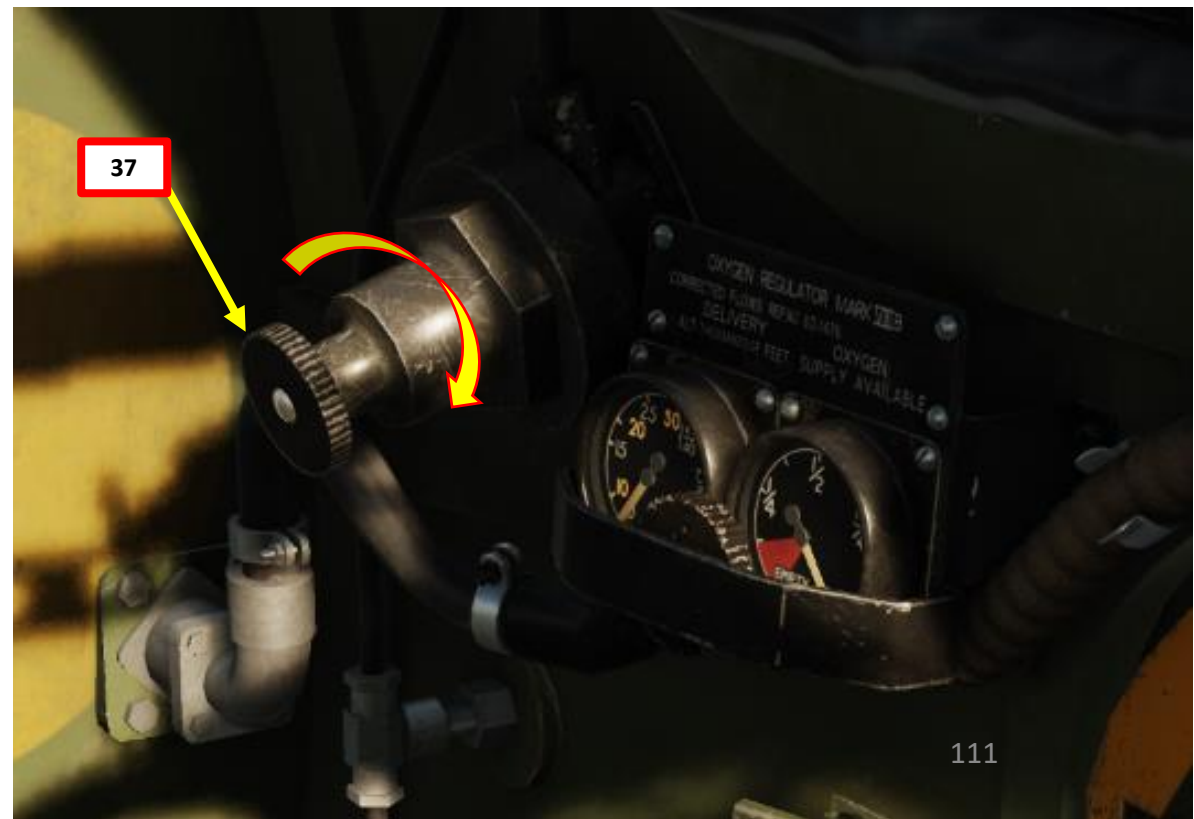
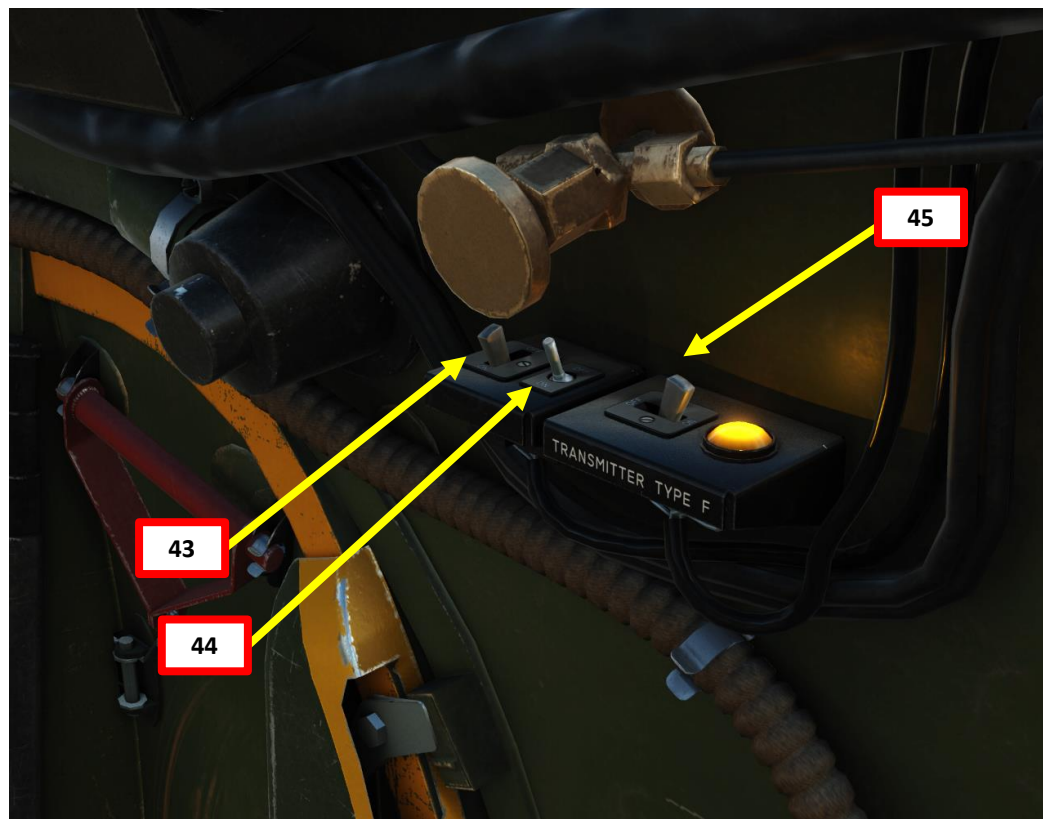
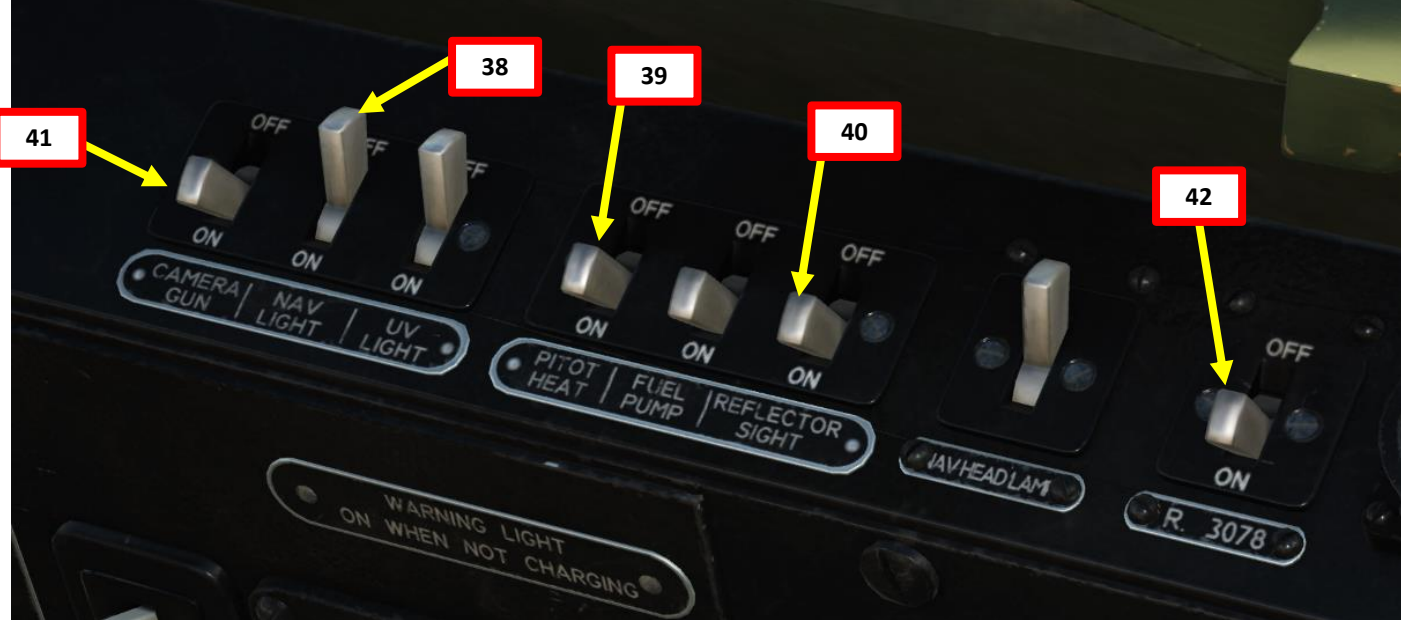

POST-START

46. Lower the armored headrest of the navigator seat to access the radio compartment by clicking on the headrest handle.
47. Set A.R.I. 5083 IFF (Identify-Friend-or-Foe) Power Switch – ON (UP)
48. Set A.R.I. 5083 IFF Channel – As required in mission briefing.
49. Set T1154 Radio Transmitter Set Tuning Control knob – STD-BI (Standby).
50. Set R1155 Radio Receiver – As required.
 - T1154/R1155 Radio Set Tutorial is further explained in the Radio section.

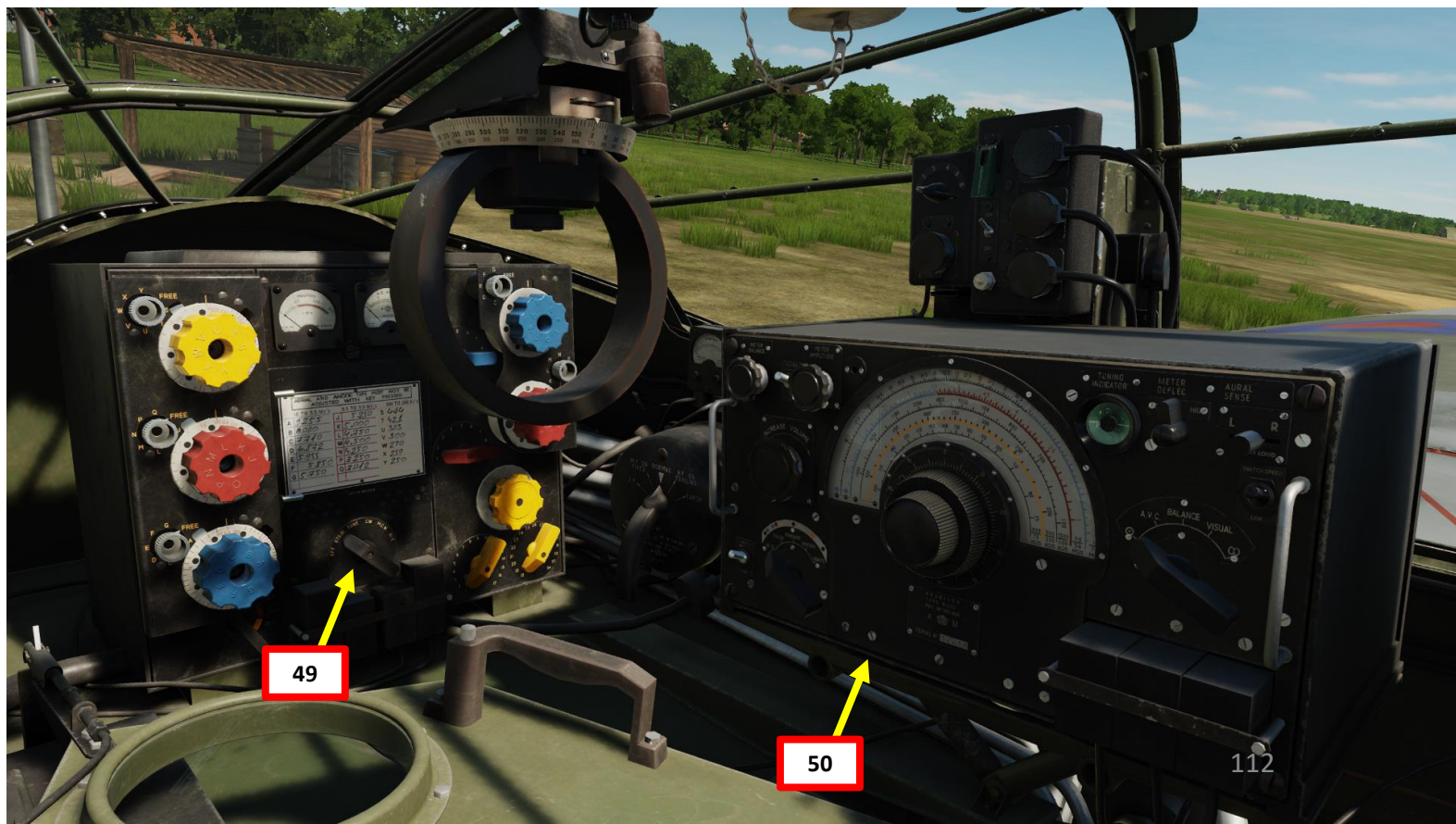
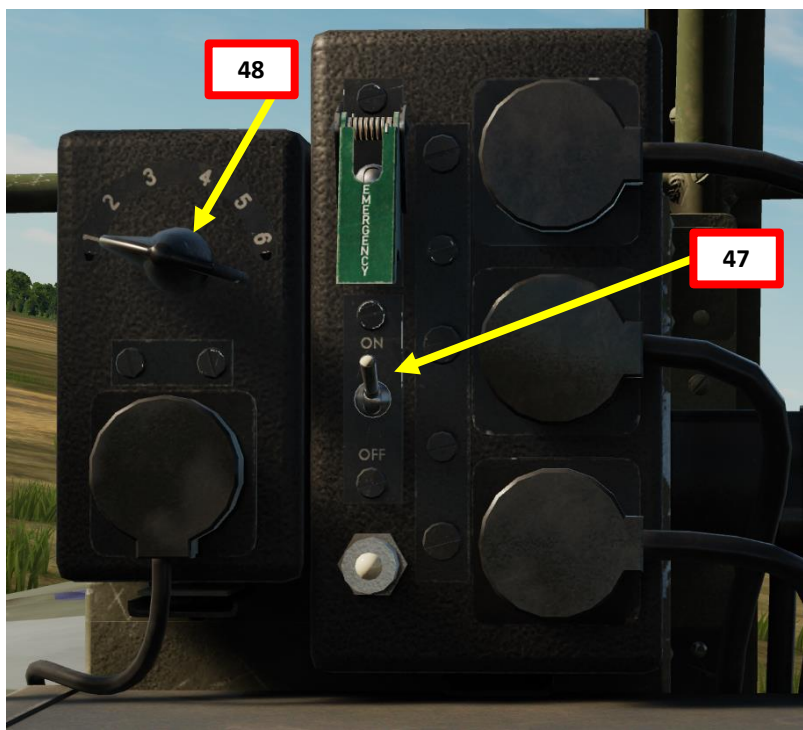



POST-START

51. Raise the armored headrest of the navigator seat.
52. Select Pilot Seat by pressing “1”
53. Close side window.

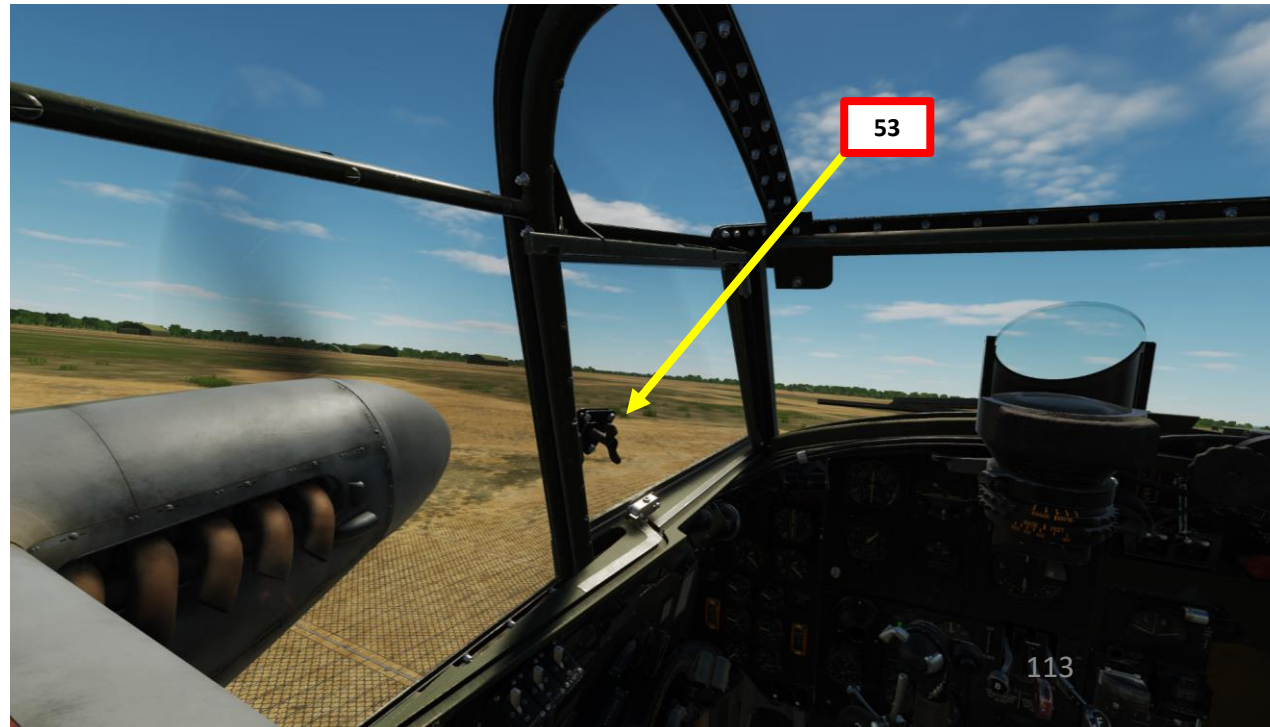

ENGINE WARM-UP

1. Ensure oil pressure is in the 60-120 psi range.
2. Adjust throttle to a RPM of 1200 (IDLE).
3. Wait until engine oil warms up above 20 deg C and radiator coolant temperature is above 40 deg C.
4. Once both engines are warmed up, you may start taxiing.

Note: Attempting a takeoff with low oil or coolant temperature can lead to dire consequences. Waiting for proper engine warm-up is often overlooked by virtual pilots and the Merlin engine leaves no room for error when engine temperatures are concerned.

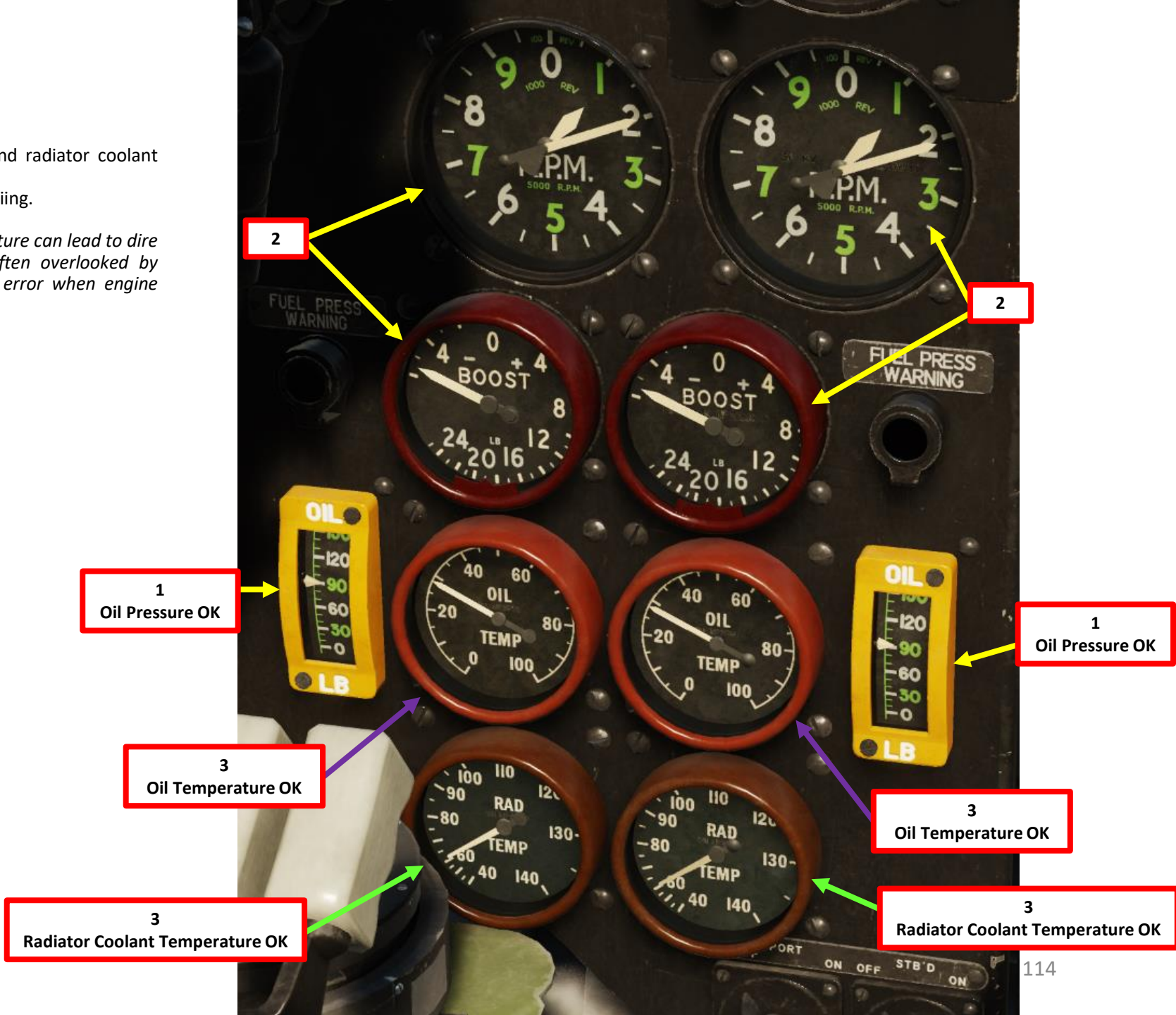

TAXI PROCEDURE

1. Ensure engine oil temperature is between 20 and 80 deg C, oil pressure is between 60 and 120 psi, and coolant temperature is between 40 and 120 deg C.
2. Set Fuel Cock Selectors to the fullest tanks.

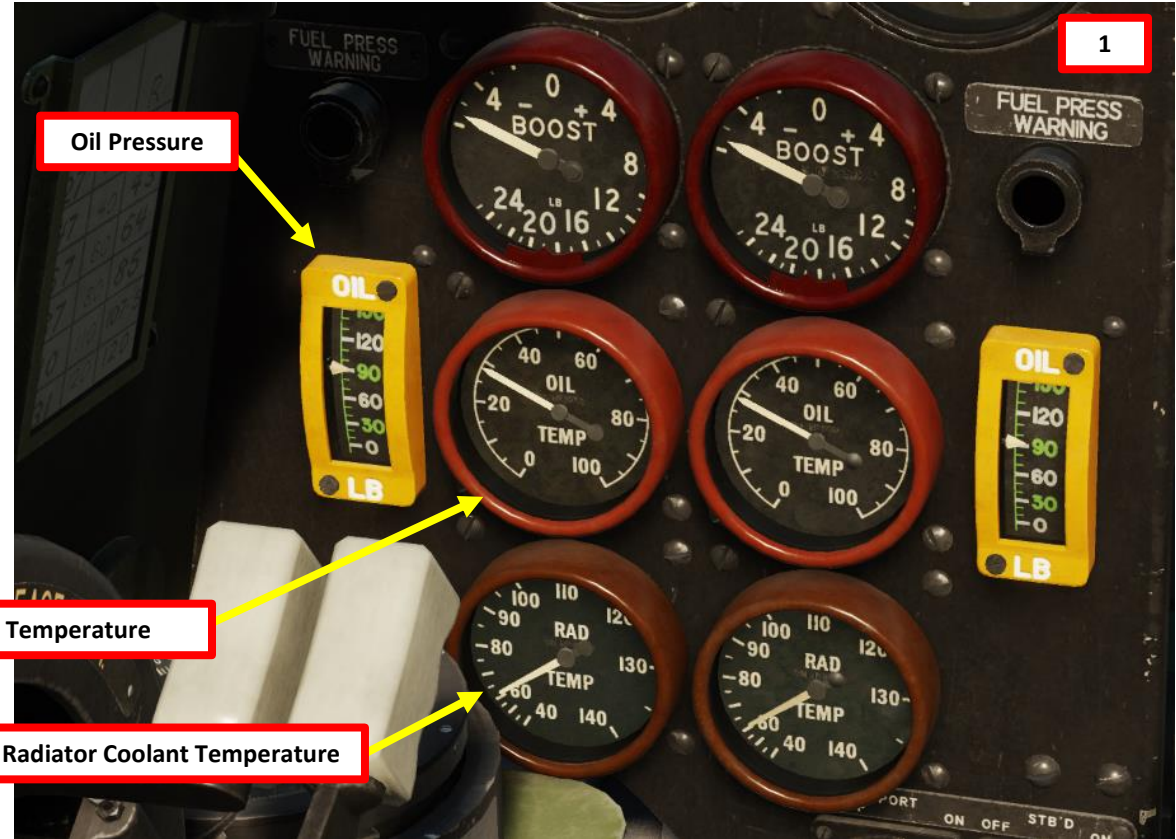
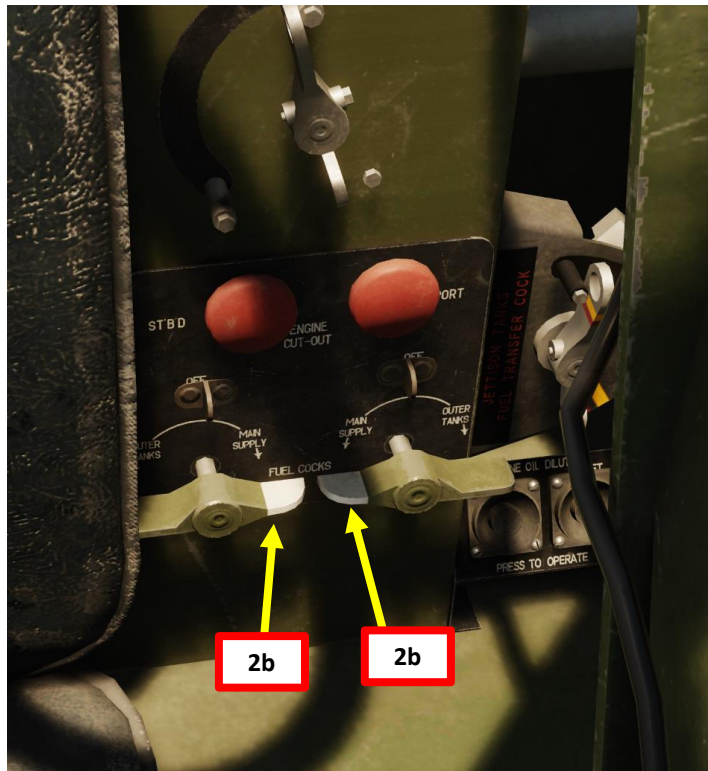

2a
Fullest Tanks – INNER (MAIN SUPPLY)



TAXI PROCEDURE

3. Ensure pneumatic pressure is no less than 200 psi.
4. Start taxiing when engine is warmed up by releasing the Parking Brake (press on the Brake Lever to release the brakes).
5. Throttle up and check brake effectiveness.
6. Set throttles to 1200 RPM, open canopy and start taxiing. Reduce throttles as required to maintain a safe taxi speed. While taxiing, keep the stick pulled fully aft.
7. To execute a turn, press and hold the wheel brake lever while simultaneously giving rudder input in the desired direction. The brakes are pneumatically actuated.
8. Line up on the runway.

Note: During taxi, keep the control stick pulled completely AFT to ensure that the tailwheel remains straight.



Brake Lever

4



7

Tailwheel

BRAKING TIPS

Braking is done by holding the braking lever while giving rudder input to steer the aircraft in the direction you want to turn. Make sure you have adequate RPM and Boost/Manifold Pressure settings or your turn radius will suffer. The best way to move safely on the tarmac is to give very gentle throttle input to ensure you maintain control of the aircraft while steering left and right once in a while to check for obstacles to ensure that the tailwheel remains straight.

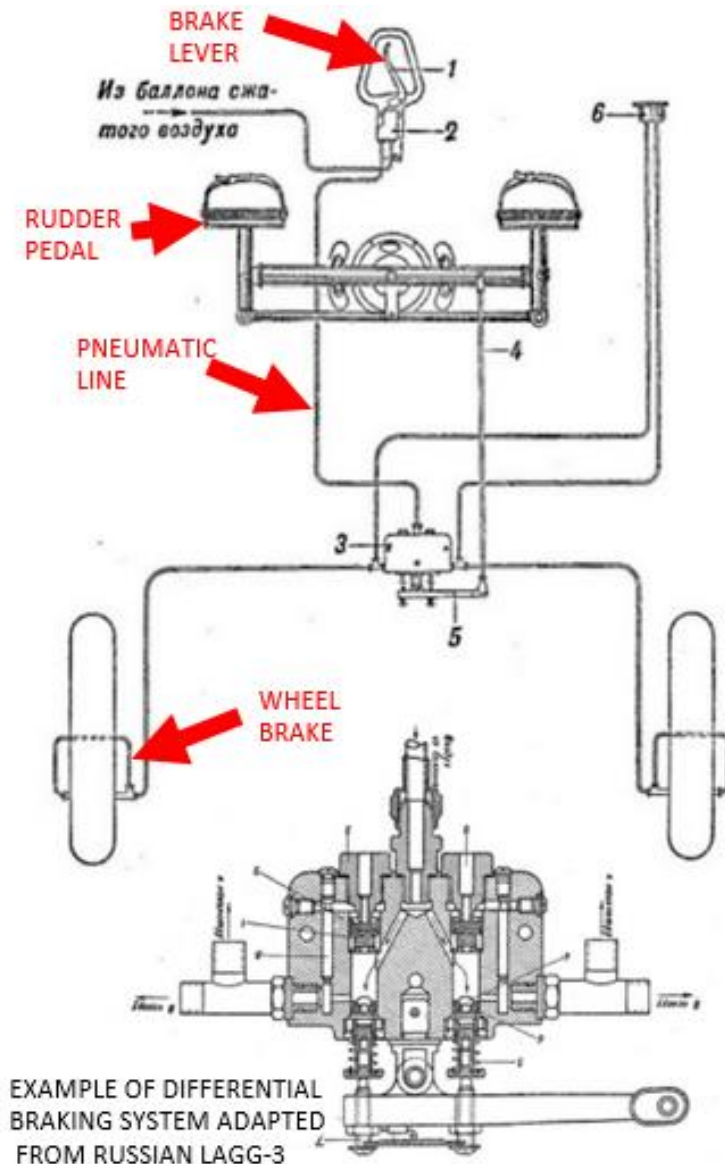
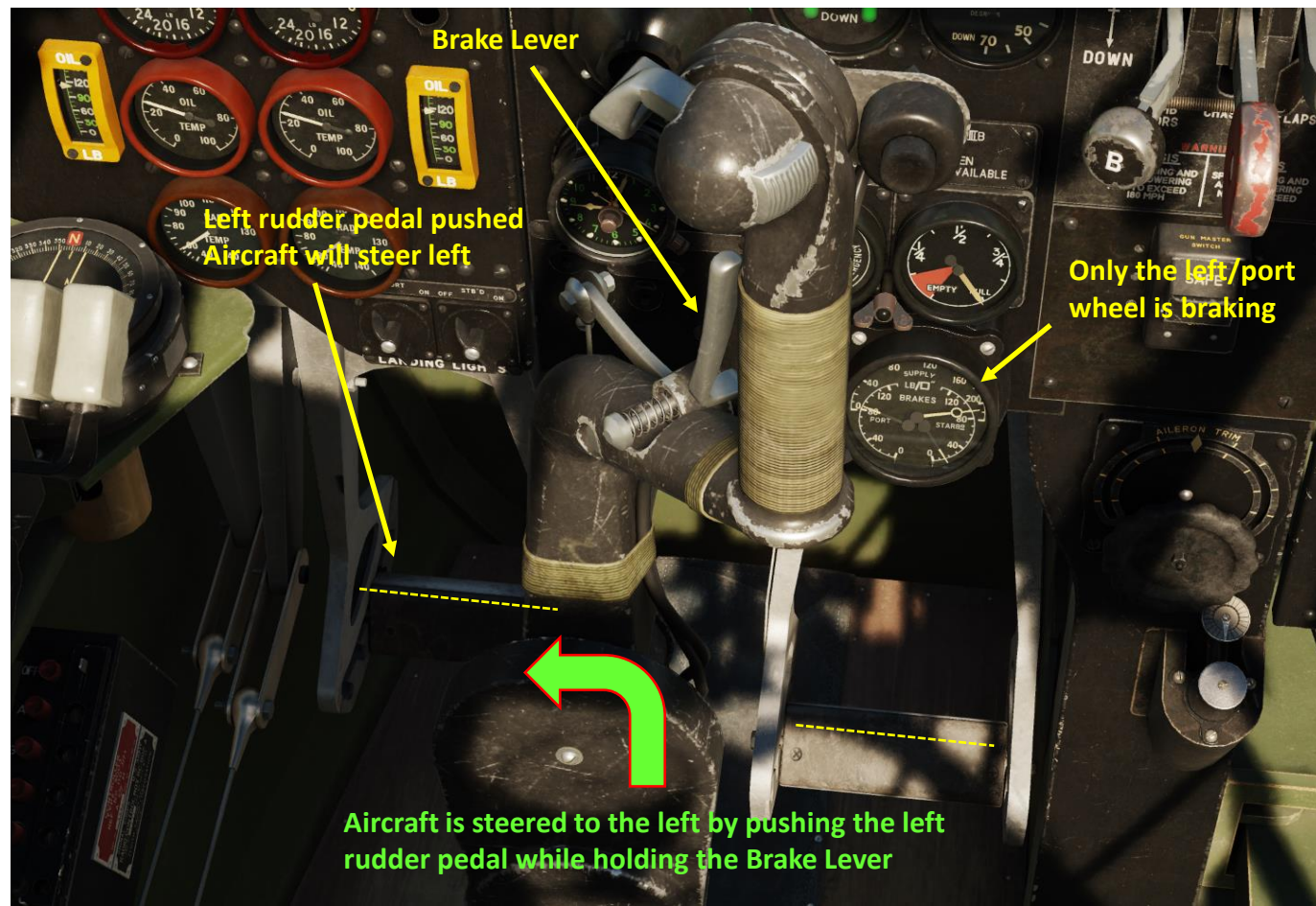

TAKEOFF PROCEDURE

1. Set Flaps – 15 deg or higher.
 - a) Unlock Flap Control Lever Safety Catch
 - b) Hold Flap Lever – DOWN
 - c) When Flap Lever is in desired position (15 deg or more), set the Flap Lever back to the NEUTRAL (MIDDLE) position.
 - Note: You can takeoff with no flaps if desired, but only with light payloads. In that case, you will need a longer runway.



1a



1c

TAKEOFF PROCEDURE

2. Ensure RPM Control levers are fully forward
3. Set Elevator Trim for takeoff setting
 - Light Payload (No Bombs/Rockets) with no flaps: 0.5 division Nose DOWN
 - Light Payload (No Bomb/Rockets) with flaps: 2 divisions Nose DOWN
 - Heavy Payload (Bombs/Rockets) with flaps: 2.5 divisions Nose DOWN
4. Set Rudder Trim – half a division RIGHT (DOWN), roughly aligned on the “T” of “TRIM” letters.
5. Set Aileron Trim – NEUTRAL
6. Ensure Supercharger Switch is set to Moderate / Lower Gear (DOWN)
7. Confirm Radiator Shutters – OPEN (DOWN).

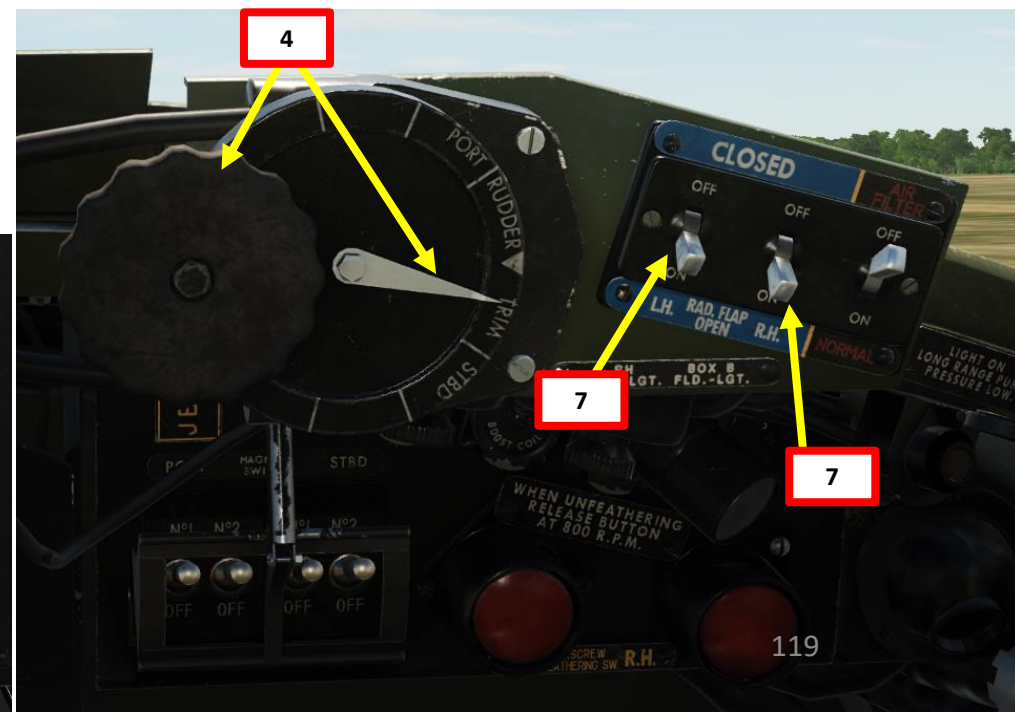
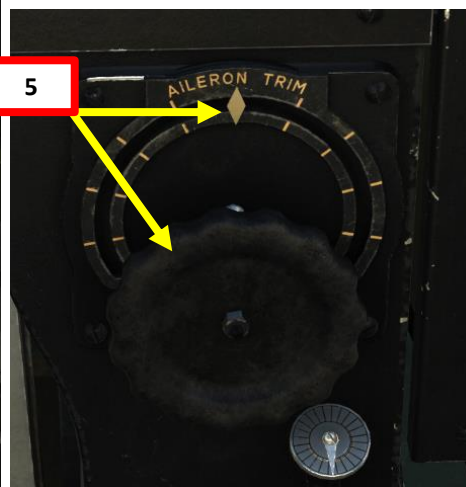
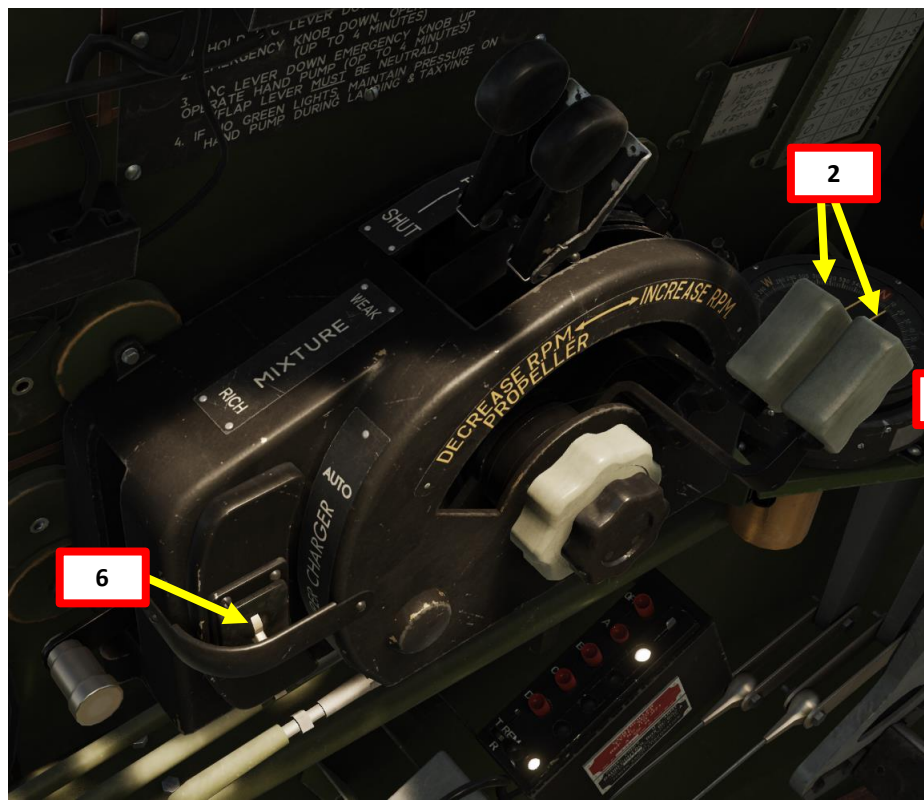
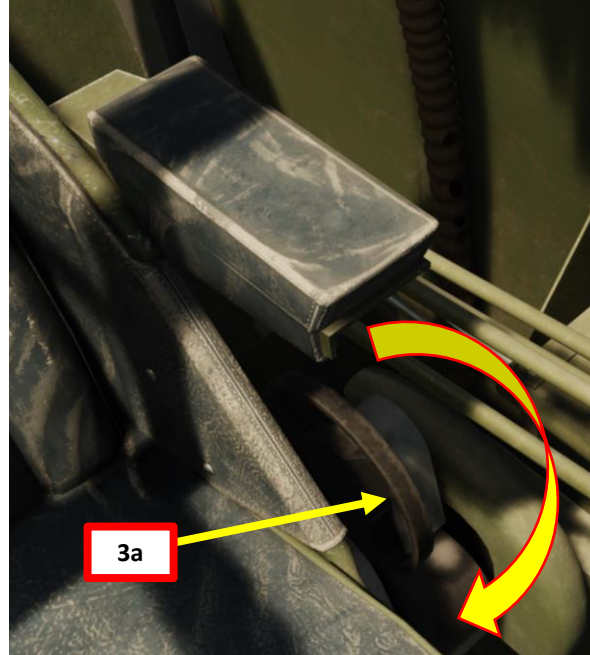

TAKEOFF PROCEDURE

8. Pull stick fully back to ensure that tailwheel remains straight.
9. Hold the Wheel Brake Lever
10. Advance the throttles slowly, checking any tendency to swing by coarse use of the rudder and by differential throttle movement. There is little tendency to swing if the engines are kept synchronized.
 - Keep in mind that the **throttles are very sensitive**; a very small throttle movement can generate a big power change.
11. Release Wheel Brake Lever, then increase power. There are two different methods to increase power for takeoff:
 - **Method 1 (recommended for light payloads):** Advance both throttles to +0 Boost, which will allow you to accelerate to 35 mph (speed at which the rudder becomes effective). When reaching 35 mph, throttle up to +9 Boost (Takeoff Power). Make sure you have enough runway for this method.
 - **Method 2 (recommended for heavy payloads):** Gradually advance both throttles to +9 Boost (Takeoff Power), but lead with the left throttle. Once the tail starts rising (meaning that rudder control is becoming effective), balance out the throttles.
12. Slowly release control stick to center position as aircraft gains speed (above 35 mph) and tailwheel leaves the ground.
13. Keep the aircraft lined up on the runway with rudder pedals as the aircraft accelerates.
14. The aircraft should start lifting off the ground by itself as you gain speed above 100 mph.
15. Safety speed (vary with aircraft loadout):
 - At a weight of approx. 17000 lbs flaps up (or 15 deg down) at +9 boost, safety speed is 180 mph.
 - At a weight of approx. 17000 lbs flaps up (or 15 deg down) at +18 boost, safety speed is 200 mph

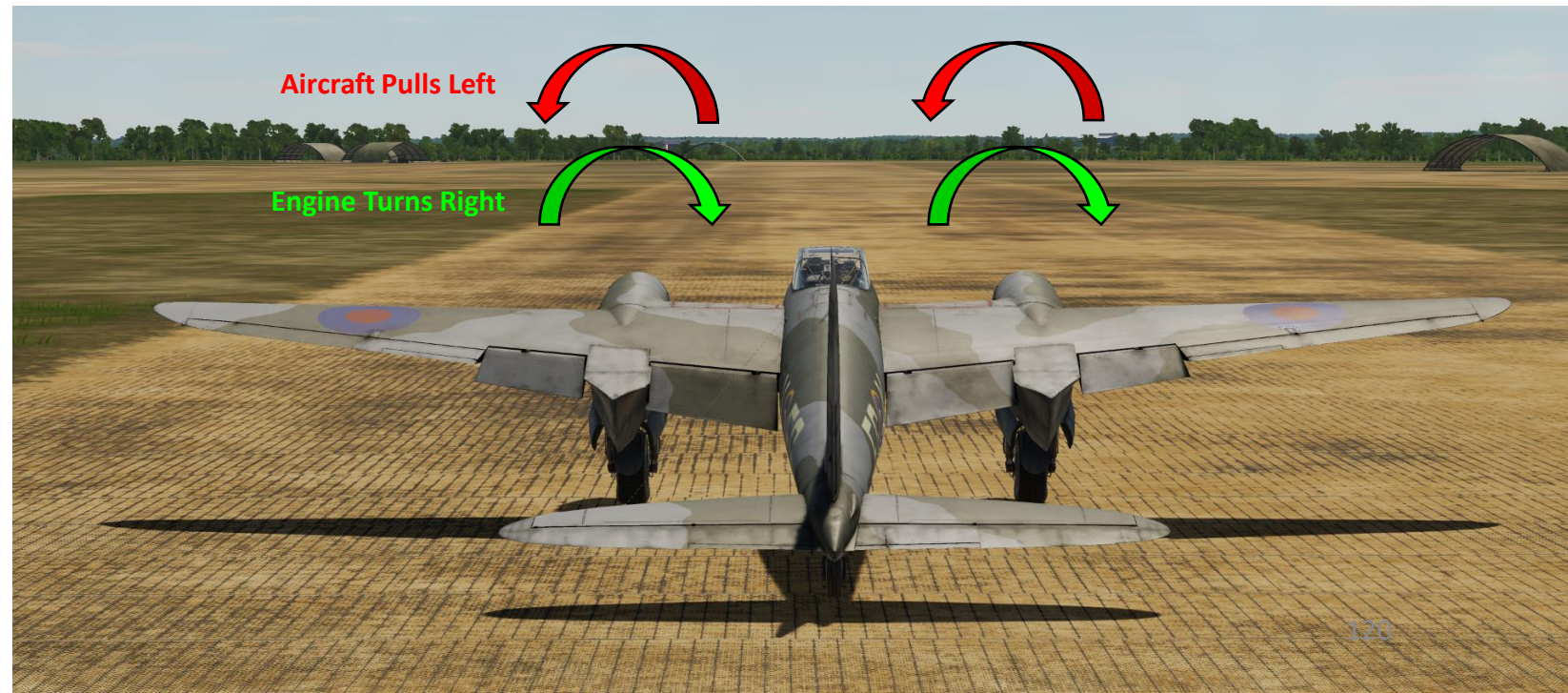

Note:

Both engines turn to the right (clockwise), which makes the aircraft want to swing towards the left. Wouldn't it have been easier to have two engines rotating in the opposite direction to help minimize the induced torque?

Part of the reason behind this seemingly odd choice is that using two engines rotating in the same direction helped streamlining the production and reducing manufacturing costs, since creating a different engine variant required additional assembly lines.



DH.98 MOSQUITO
FB MK VI

PART 5 - TAXI & TAKEOFF

TAKEOFF PROCEDURE



TAKEOFF PROCEDURE

16. Once in the air, tap wheel brake to stop the wheels from spinning, then raise Landing Gear (Undercarriage) using the Landing Gear Lever.
- Unlock Landing Gear Control Lever Safety Catch
 - Set Landing Gear Lever – UP (RETRACT)
 - Once Landing Gear is retracted and locked, set Landing Gear Lever – NEUTRAL (MIDDLE).
- Note: Landing gear should be raised before reaching an airspeed of 180 mph. Failing to respect this airspeed limit may cause the landing gear to jam.*



16a



16a

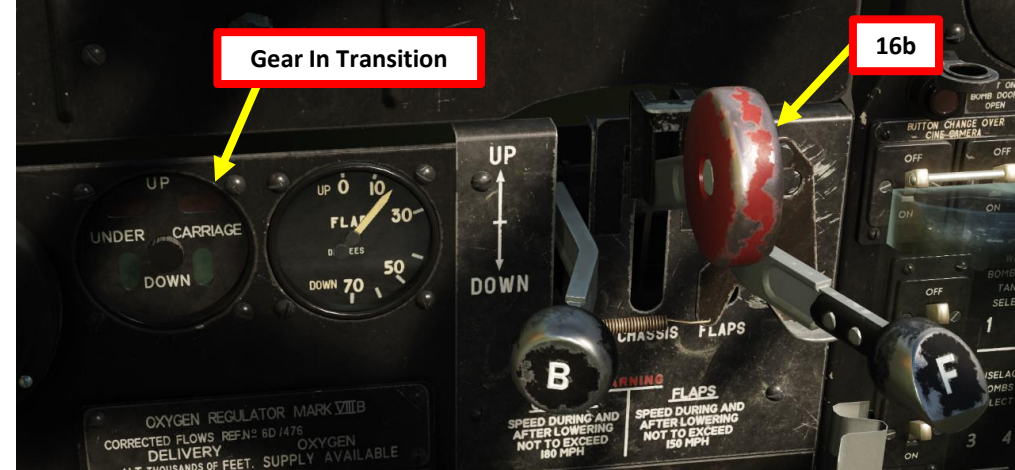

16b

Gear Up



16c

TAKEOFF PROCEDURE

17. If the flaps have been used for takeoff:
Once landing gear is retracted and locked, raise flaps setting the Flaps Lever UP, then back to the NEUTRAL (MIDDLE) position once the flaps position have reached 0 deg.
- Note: Flaps should be raised before reaching an airspeed of 150 mph. Failing to respect this airspeed limit may cause the flaps to jam.*

VIDEO DEMO:

<https://youtu.be/S8aa9d4qeDs?t=1739>





CLIMB

18. Start climbing at 170 mph (best climb speed) and adjust power with throttles and RPM control levers
 - If maximum continuous rate of climb is required, use +9 psi boost and 2850 RPM.
 - If maximum rate of climb is not required, use +7 psi boost and 2650 RPM. Doing so conserves fuel and increases total flight range.
 - Note: when climbing with a boost setting of less than +9 Boost (psi), the automatic boost control cannot open the throttle valves fully and the boost will begin to fall off before full throttle height is reached. The throttles should be progressively advanced to the gate to maintain the desired boost.
19. When Boost decreases below +4 psi as altitude increases and air density decreases, set Supercharger Switch – Automatic Gear (UP). Then, re-adjust throttles accordingly.
20. When flying above 18000 ft, decrease climb speed by 3 mph per 1000 ft.

CRUISE

21. Recommended cruise speed is 240 mph (both engines operating) or 180 mph in case of a single engine failure.

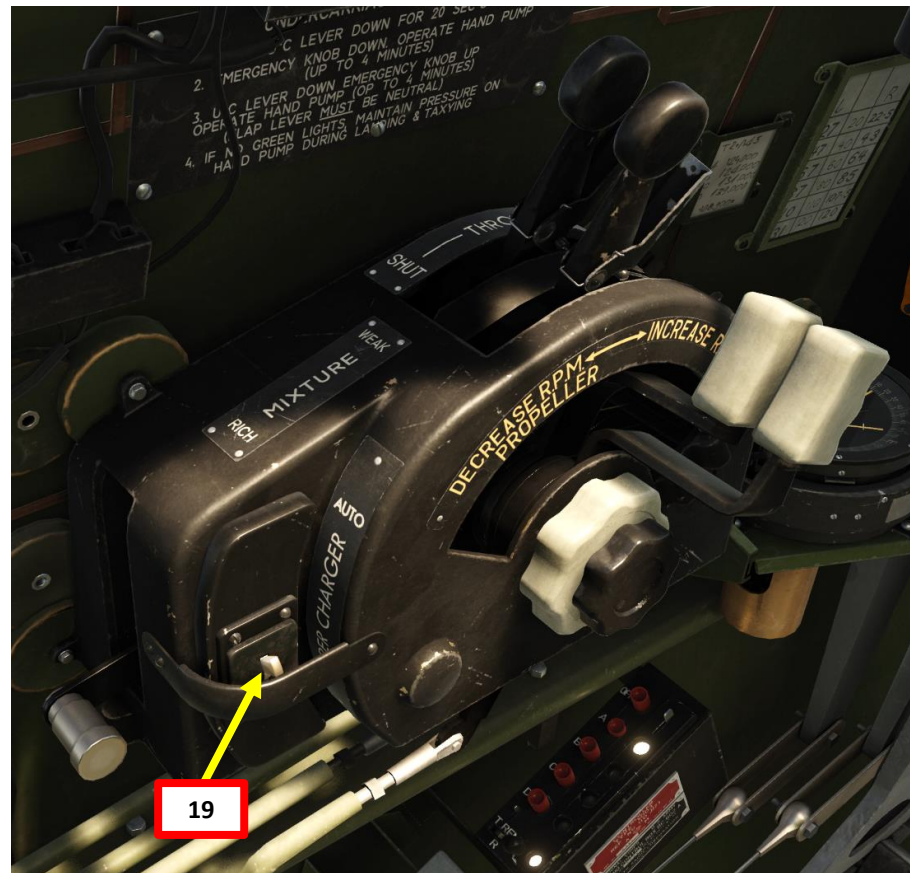

NORMAL LANDING PROCEDURE

1. Check that brake pressure is at least 200 psi
2. Set Supercharger Switch to Moderate / Lower Gear (DOWN)
3. Confirm Radiator Shutters – OPEN (DOWN)
4. Set Fuel Cock Selectors to the fullest tanks.
5. Adjust RPM Control Levers to maintain 2850 RPM.

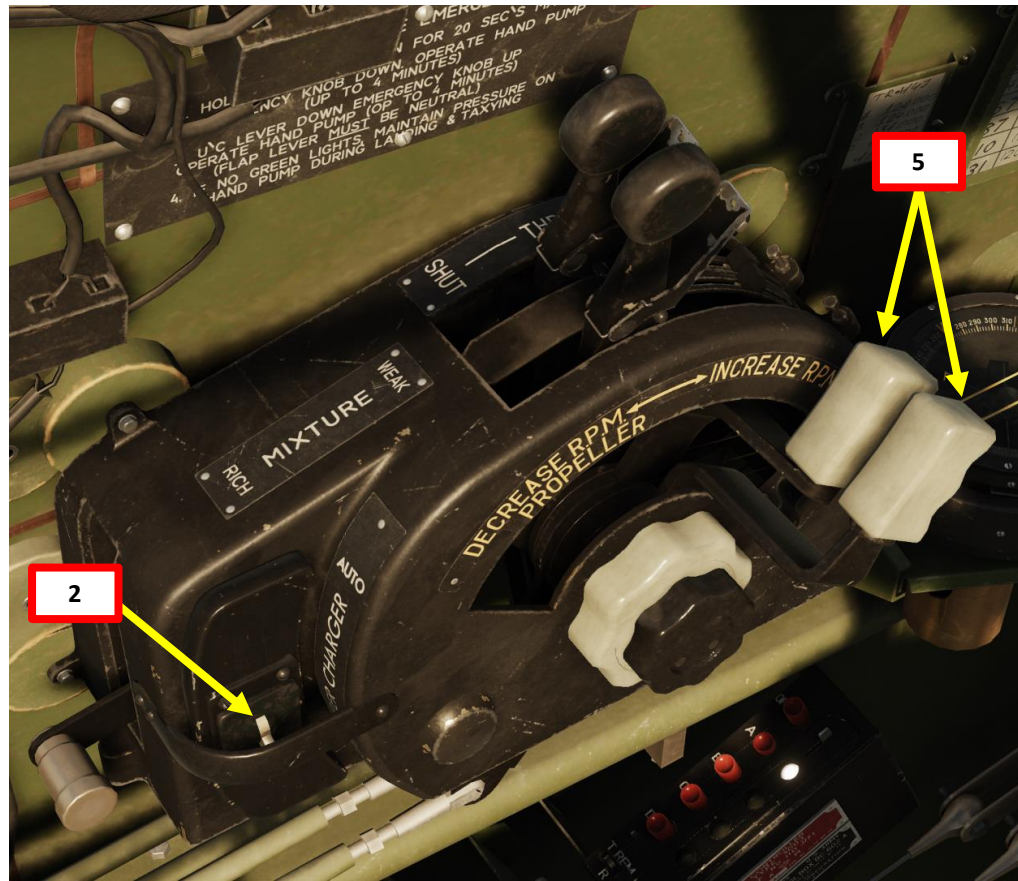
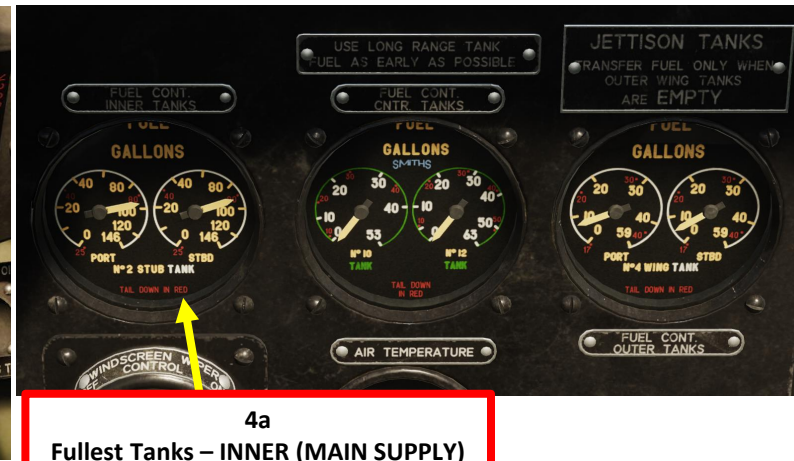

NORMAL LANDING PROCEDURE

6. Set Navigation Lights – As Required
7. Set Landing Lights – As Required
8. Reduce throttle and decelerate to 180 mph.
9. As you reduce throttles below approx. +7 boost, you will hear a warning horn. This horn is triggered when the throttles are below maximum continuous power (below about 1/4 of the total throttle travel) and the landing gear is not extended.
10. Enter downwind leg at 1000 ft altitude.

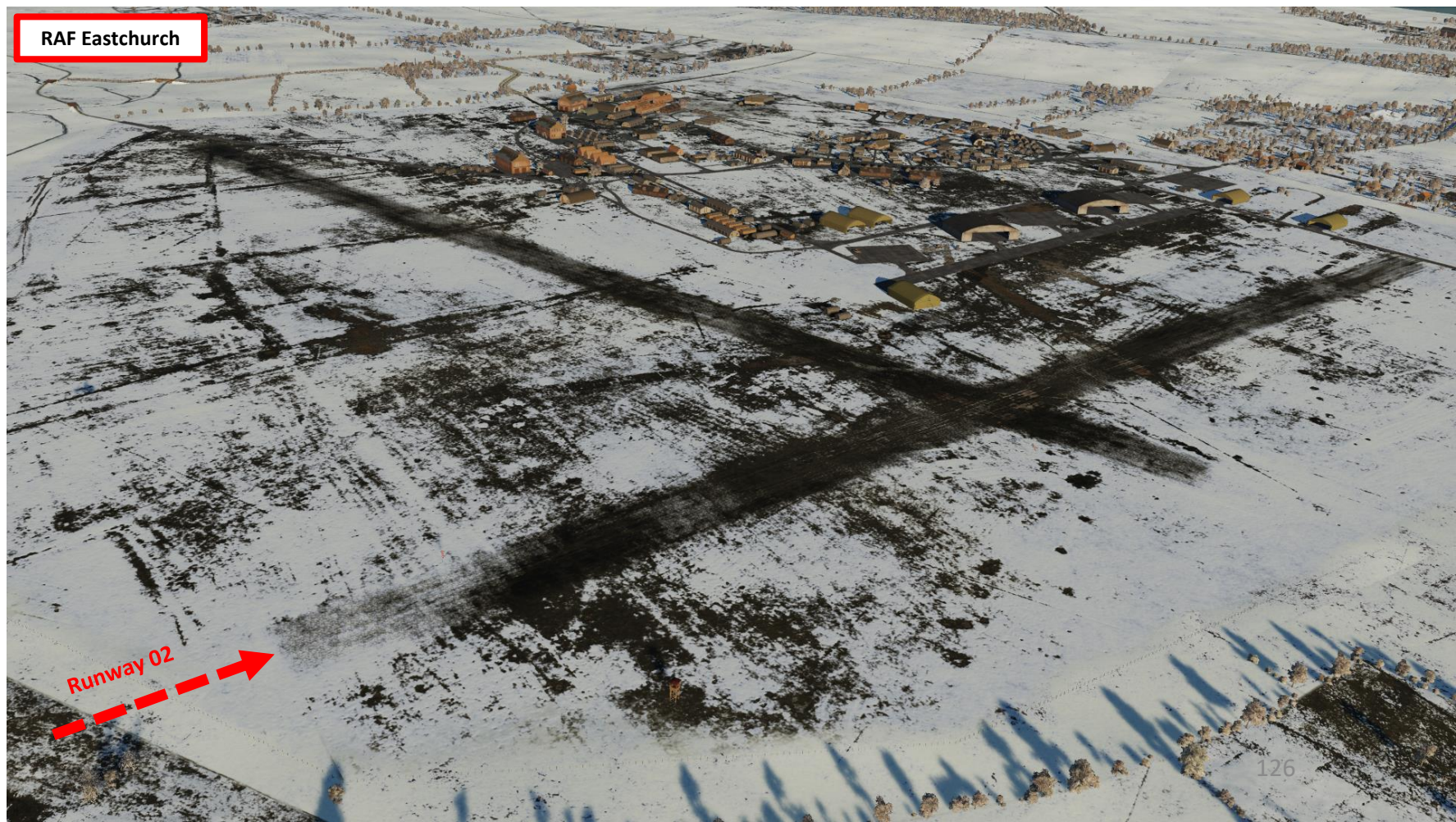
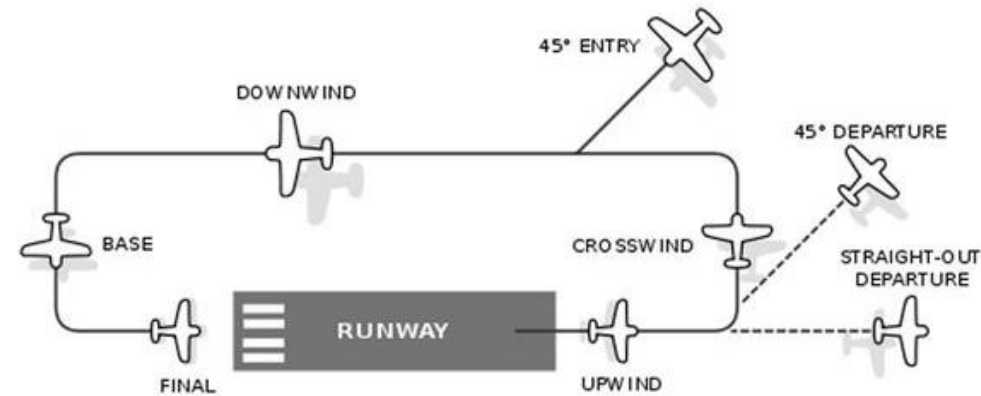

NORMAL LANDING PROCEDURE

11. Deploy landing gear (lever DOWN) when you slow down below 180 mph. Set lever back to NEUTRAL (MIDDLE) once landing gear is fully deployed and locked.
12. Trim the aircraft to a stable attitude with the elevator trim wheel.
13. Once your wingtip is abeam the runway threshold, deploy flaps to 45 deg (at 150 mph or less) and enter base leg with a descending turn.
 - a) Unlock Flap Control Lever Safety Catch
 - b) Hold Flap Lever – DOWN
 - c) When Flap Lever is in desired position (45 deg), set the Flap Lever back to the NEUTRAL (MIDDLE) position.
 - *Note: landing with no flaps can also be performed at light weights, but the approach speed is about 15 mph higher.*
14. Trim the aircraft (nose down) to a stable attitude with the elevator trim wheel.
15. Maintain 150 mph until you have the runway threshold in sight.

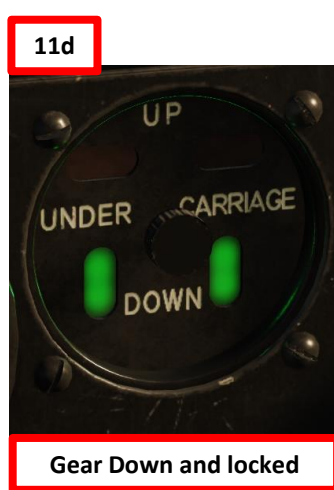
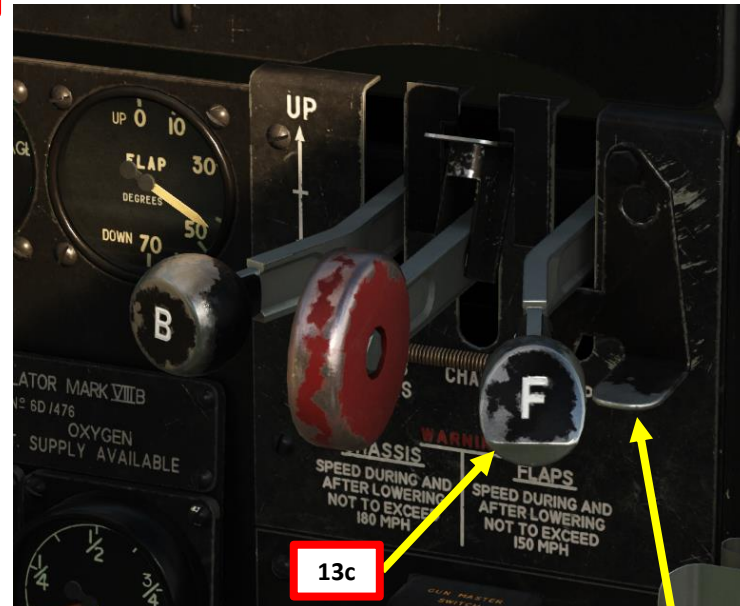
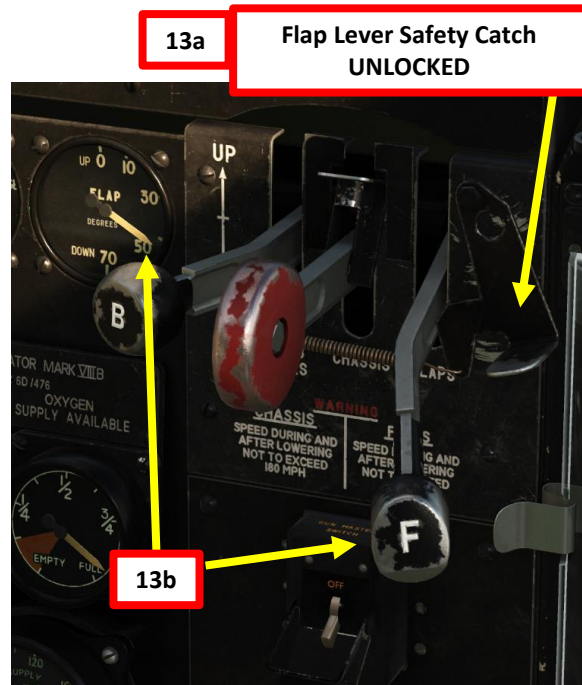

NORMAL LANDING PROCEDURE

16. Maintain eyesight of the runway threshold as your turn and enter final at 500 ft altitude.
17. Set Engine RPM Control Levers to set 3000 RPM.
18. Approach speed should be as follows:
 - **With Flaps:** 125 mph
 - **Without Flaps:** 140 mph
 - *Note: at heavy weights, approach speed target should be increased by 10 mph.*
19. When flying over runway threshold, throttle back to set power to IDLE.
20. Gently flare for a three-point landing and maintain attitude until your touchdown.
21. Use rudder pedals to stay straight on the runway as you decelerate.
22. Start using the wheel brake lever in short bursts when rudder movement becomes ineffective.
 - *WARNING: Excessive braking may cause the aircraft to nose over.*
23. Raise flaps and taxi back to the parking area.

Note: *During landing, the aircraft will feel extremely floaty when flaps are deployed. Controlling the speed at which you touch the ground is essential in order to avoid nasty bounces.*

VIDEO DEMO:

<https://youtu.be/S8aa9d4qeDs?t=1991>





DH.98 MOSQUITO
FB MK VI

PART 6 – LANDING

NORMAL LANDING PROCEDURE





DH.98 MOSQUITO
FB MK VI

NORMAL LANDING PROCEDURE



PART 6 - LANDING



DH.98 MOSQUITO
FB MK VI

NORMAL LANDING PROCEDURE

PART 6 – LANDING





BALKED (REJECTED) LANDING

If you end up having to abort a landing and go around, keep in mind that the aircraft will climb satisfactorily at approx. 140 mph with flaps and undercarriage down at climbing power (3000 RPM at +9 Boost). To go around:

1. Advance throttles to +9 Boost (Takeoff Position)
2. Raise the landing gear immediately. Don't forget to unlock the Landing Gear Control Lever Safety Catch or the lever will stay stuck at NEUTRAL (MIDDLE).
3. Climb at 140 mph.
4. The flaps come up quickly and should not be raised until safe height is reached. Flaps may be kept at 25 deg to complete the circuit; there is then no need to retrim.





DH.98 MOSQUITO
FB MK VI

PART 7 – ENGINE & FUEL MANAGEMENT



Screenshot from Plane Mechanic Simulator

THE MERLIN 25 ENGINE

The Mosquito FB Mark VI is powered by two Merlin 25 engines, which are liquid-cooled, 12-cylinder V-twin piston engines with a compression ratio of 6:1. The throttle, fuel mixture and propeller pitch are controlled from the cockpit.

A two-speed, single-stage, liquid-cooled, high-speed centrifugal type supercharger is driven from the rear end of the crankshaft through a two-speed gearbox. Blower speed changeover is automatically controlled by electro-pneumatic actuators and an aneroid switch that operates at 15,000 feet in AUTO mode. With the exception of a separate turbocharger control unit, the Merlin SU double-choke up-thrust carburetor is fully automatic, minimizing pilot responsibility and the risk of engine damage as a result of improper control.

The drive box is mounted behind the crankcase and carries the magneto, coolant pump, generator drive, electric slewing gear and fuel pump assembly. It contains a spring drive and shafts through which the magneto, camshafts, electric generator, fuel, oil and cooling pumps are driven. The aircraft is equipped with two de Havilland three-bladed propellers, fully featherable, with hydro-automatic control type 5000. In normal operation they are controlled by speed control levers. Normal angle range is 35°, additional feathered range 45°.

The ignition system consists of two magnets located on the drive box, one on the left and one on the right. Attached to these are high voltage spark plug harnesses with a dual-purpose metal shield that acts as a collector for the induced field around the high voltage wires, returns the resulting electrical current to ground, and prevents radio interference. There are two spark plugs in each cylinder: one magneto provides a spark for the intake side spark plugs and the other for the exhaust side spark plugs to ensure that the engine remains operational if one of the magnetos fails.

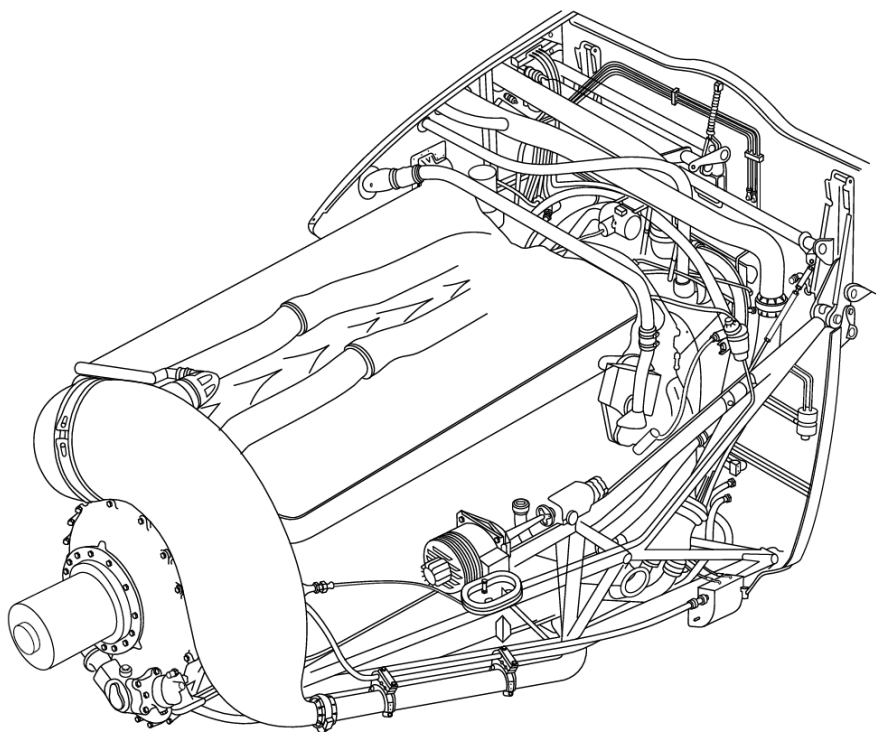

THE MERLIN 25 ENGINE

1. Coolant Outlets
2. De-icing Connection to propeller
3. Vacuum Pump Inlet
4. Vacuum Pump Return
5. Engine Mounting Feet
6. Oil Pressure Gauge Connection
7. Oil Thermometer Gauge Connection
8. De-icing Inlet Connection
9. Coolant Inlet to Cylinder
10. Dowty Pump Drain
11. Oil Inlet
12. Coolant Pump Outlet
13. Coolant Pump Inlet
14. Starter Motor Terminals
15. Supercharger Bearing Vent
16. Slow-running Cutoff Lever
17. Oil Outlet
18. Constant-speed Propeller Governor Unit
19. Wheelcase Breather Vent
20. Magneto Earthing Connection
21. Magneto Booster Coil Connection
22. Throttle Control Levers (alternative)
23. Boost Gauge Connection
24. Cabin Heater Connection
25. Haywood Air Compressor Outlet
26. I.A.E. Pump Delivery
27. I.A.E. Pump Drain
28. I.A.E. Pump Inlet
29. Fuel Priming Connection
30. Propeller Shaft
31. Crankcase Breather
32. Engine Starting Handle
33. Fire Extinguishing System Inlet
34. R.A.E. Air Compressor Oil Inlet
35. R.A.E. Air Compressor Air Inlet
36. R.A.E. Air Compressor Air & Oil Outlet

37. Engine-speed Indicator Drive
38. R.A.E. Air Compressor Drain
39. Boost Control Cut-Out Lever
40. Two-speed Supercharger Control
41. Fuel Pump Drain
42. Fuel Pump Inlet
43. Fuel Priming Connection to Fuel Pump
44. Oil Dilution Connection
45. Fuel Pressure Gauge Connection
46. Lockheed Pump Drain
47. Electric Generator Terminals
48. Electric Generator Air Cooling Inlet
49. Electric Generator Air Cooling Outlet

Motor Assembly

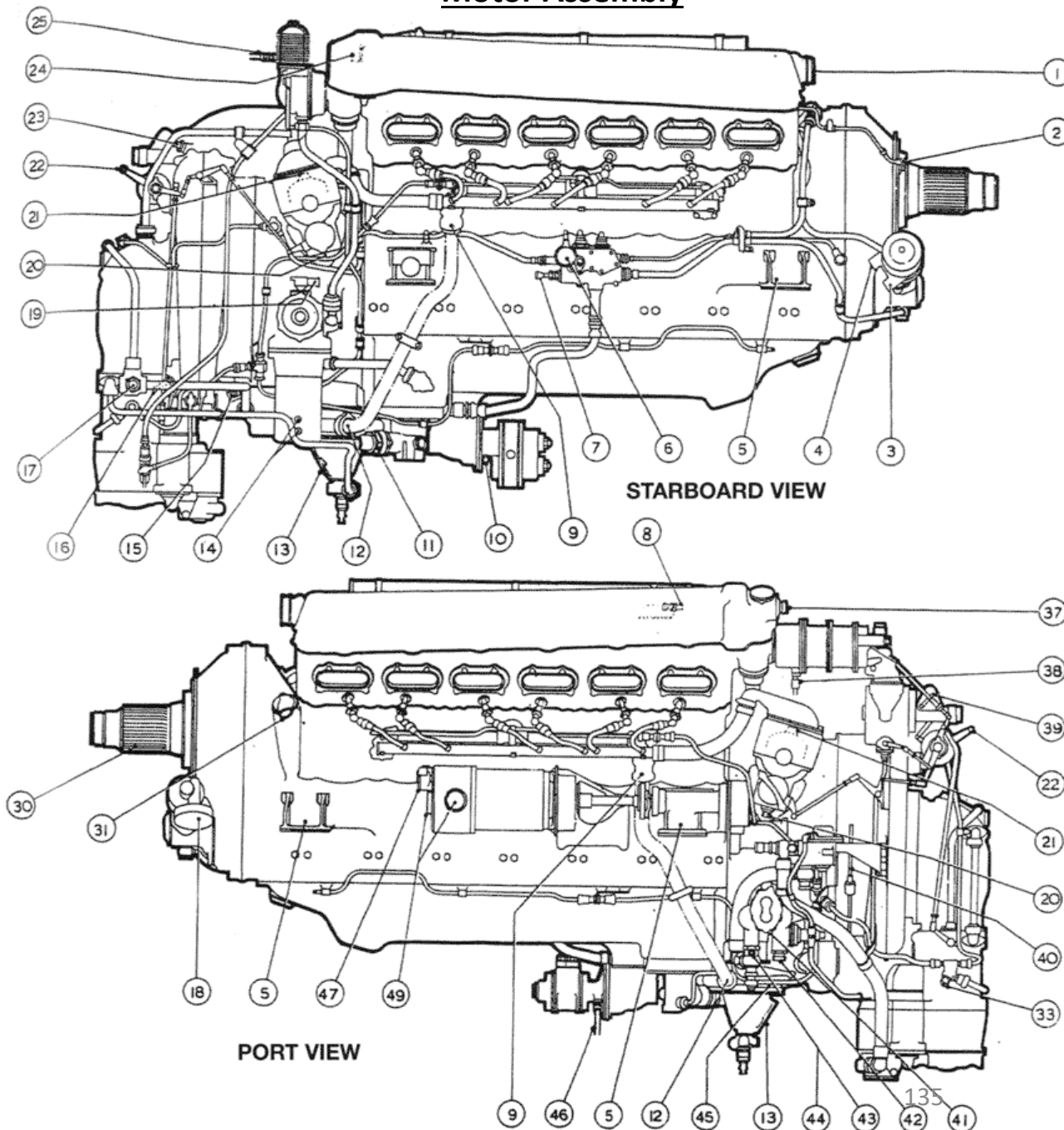

THE MERLIN 25 ENGINE

Motor Assembly

1. Coolant Outlets
2. De-icing Connection to propeller
3. Vacuum Pump Inlet
4. Vacuum Pump Return
5. Engine Mounting Feet
6. Oil Pressure Gauge Connection
7. Oil Thermometer Gauge Connection
8. De-icing Inlet Connection
9. Coolant Inlet to Cylinder
10. Dowty Pump Drain
11. Oil Inlet
12. Coolant Pump Outlet
13. Coolant Pump Inlet
14. Starter Motor Terminals
15. Supercharger Bearing Vent
16. Slow-running Cutoff Lever
17. Oil Outlet
18. Constant-speed Propeller Governor Unit
19. Wheelcase Breather Vent
20. Magneto Earthing Connection
21. Magneto Booster Coil Connection
22. Throttle Control Levers (alternative)
23. Boost Gauge Connection
24. Cabin Heater Connection
25. Haywood Air Compressor Outlet
26. I.A.E. Pump Delivery
27. I.A.E. Pump Drain
28. I.A.E. Pump Inlet
29. Fuel Priming Connection
30. Propeller Shaft
31. Crankcase Breather
32. Engine Starting Handle
33. Fire Extinguishing System Inlet
34. R.A.E. Air Compressor Oil Inlet
35. R.A.E. Air Compressor Air Inlet
36. R.A.E. Air Compressor Air & Oil Outlet

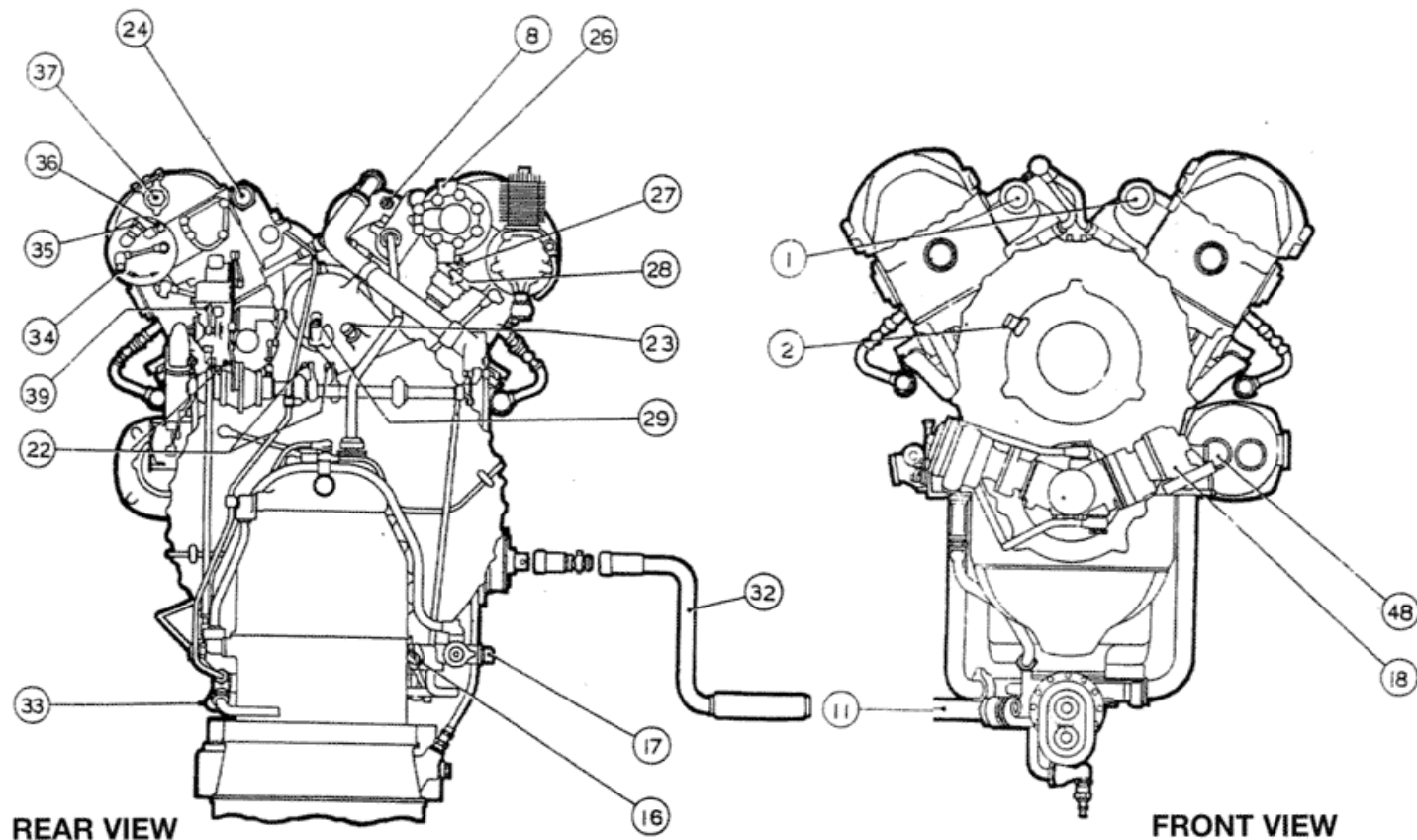

37. Engine-speed Indicator Drive
38. R.A.E. Air Compressor Drain
39. Boost Control Cut-Out Lever
40. Two-speed Supercharger Control
41. Fuel Pump Drain
42. Fuel Pump Inlet
43. Fuel Priming Connection to Fuel Pump
44. Oil Dilution Connection
45. Fuel Pressure Gauge Connection
46. Lockheed Pump Drain
47. Electric Generator Terminals
48. Electric Generator Air Cooling Inlet
49. Electric Generator Air Cooling Outlet

THE MERLIN 25 ENGINE

A coolant tank is located ahead of each engine. When the tanks and coolant lines are full, the system contains 15½ – 16 gallons of coolant: 2.6 gallons is in the tank, 3.9 pints in the radiator and cabin heater and 4.5 pints in the engine. The liquid is composed of 30% ethylene glycol and 70% distilled water. Temperature control is by means of a thermostat and a movable radiator air duct flap controlled by the pilot.

Cooling System

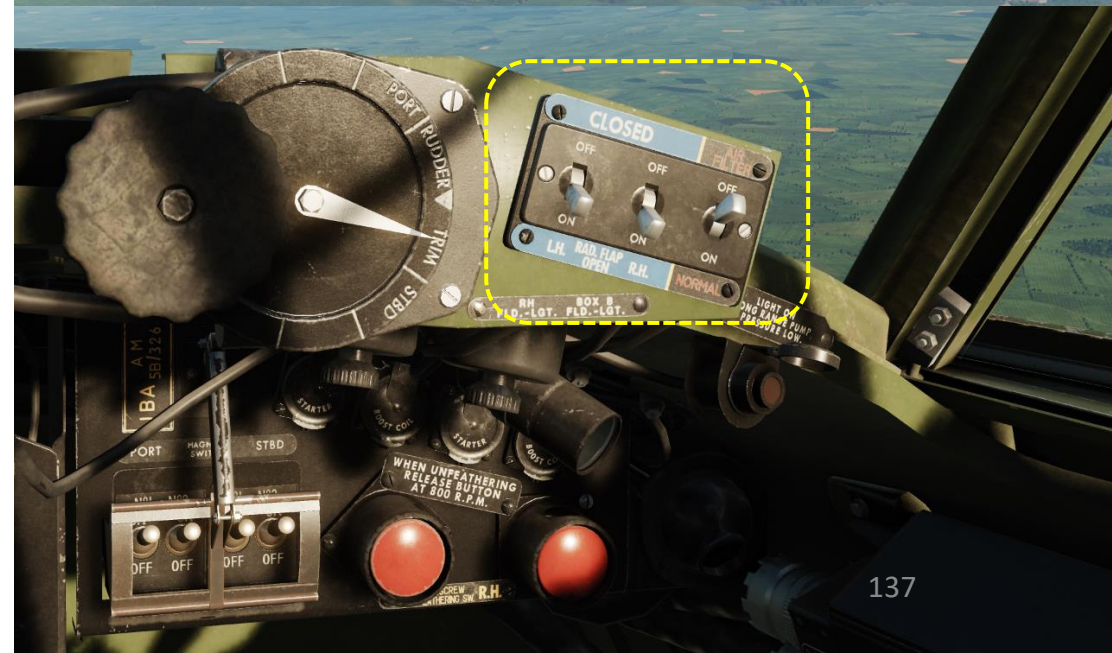
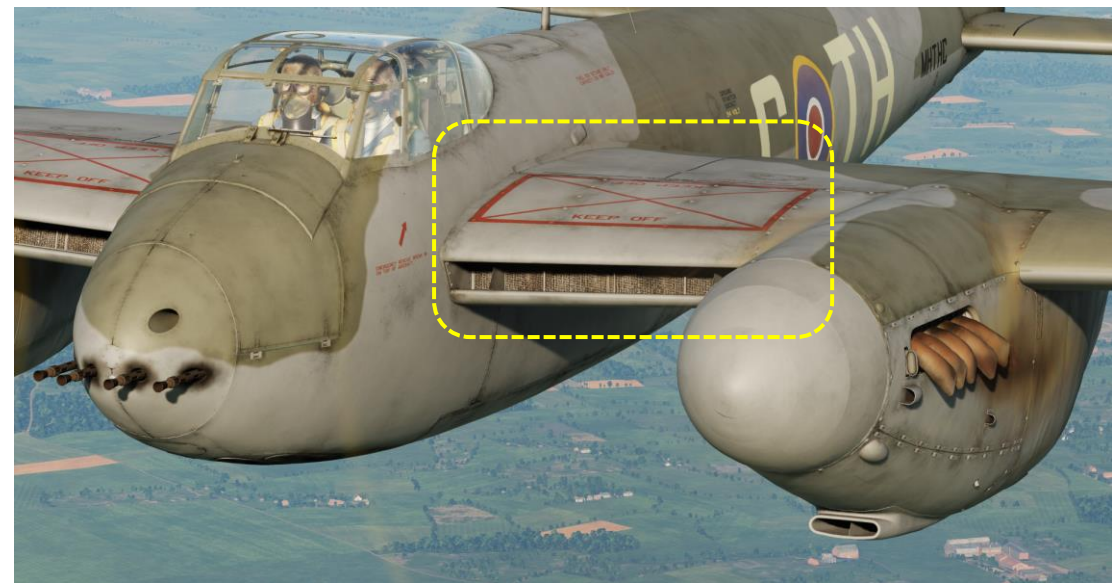
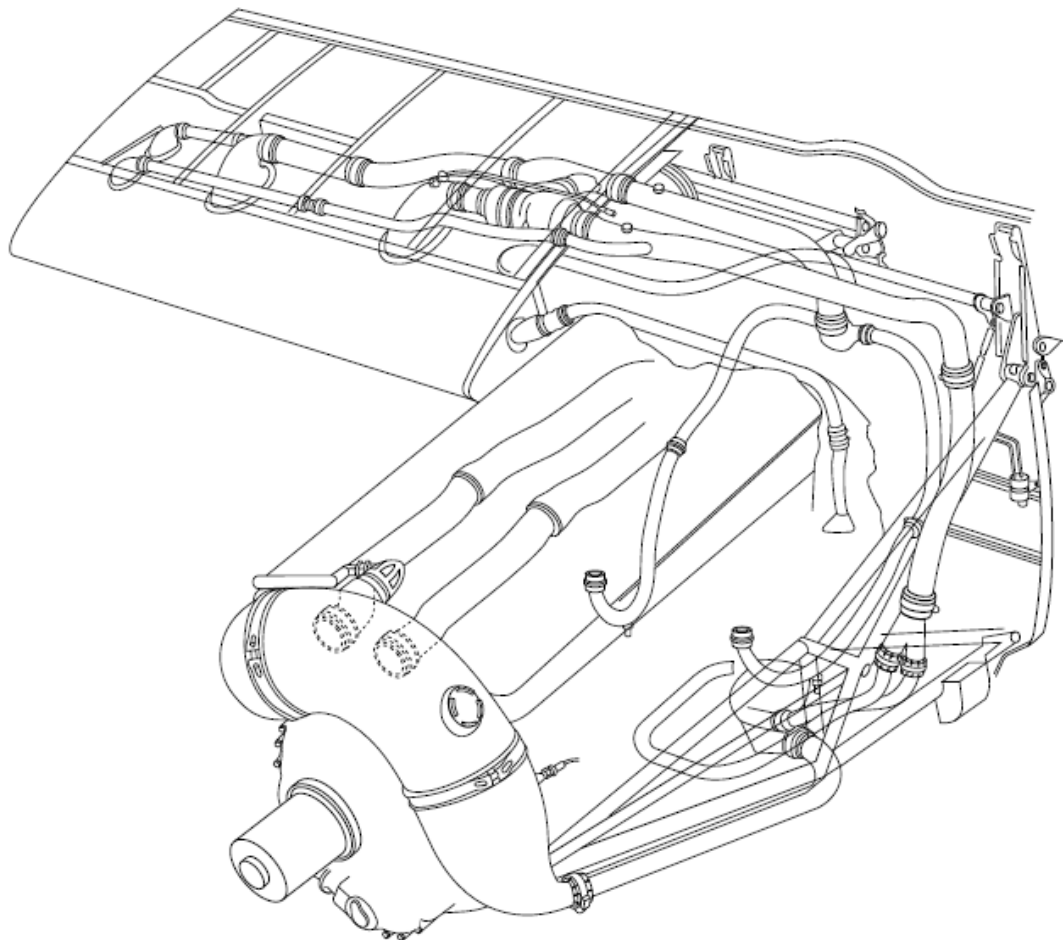

THE MERLIN 25 ENGINE

Two 15 gal oil tanks are provided and are situated one in each engine nacelle. There are no oil cooler controls for the pilot, but the coolant radiator flaps also serve the oil coolers.

There are four oil circuits in the engine lubrication system: the main pressure circuit, low pressure supply circuit, front sump purge circuit, and rear sump purge circuit.

The main and lower circuits are served by one injection pump and the corresponding safety valves, while each circuit purge is serviced by a dedicated purge pump.

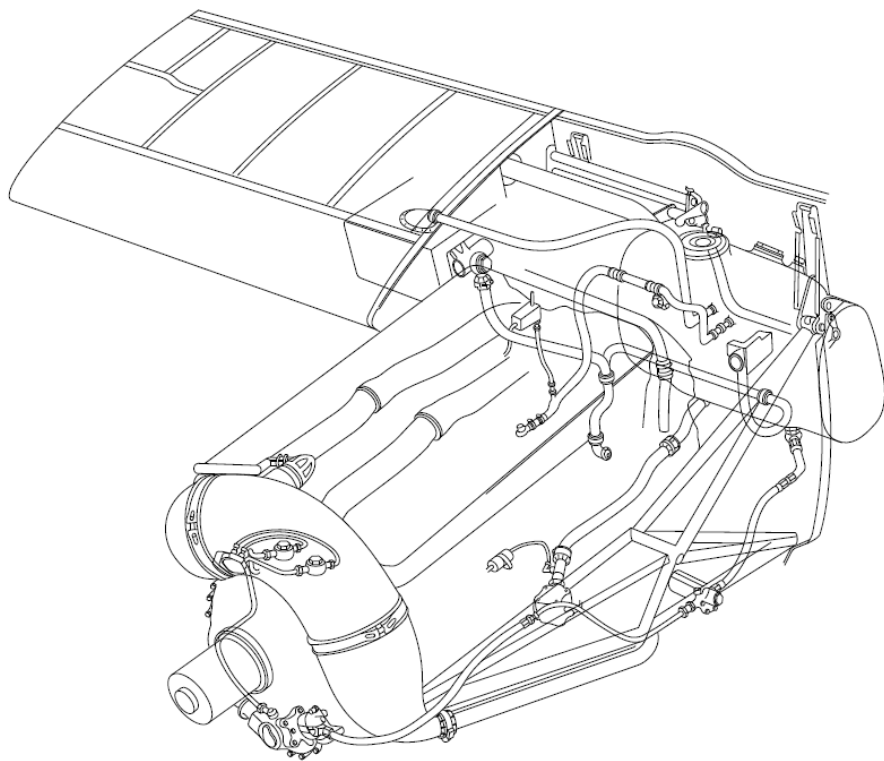

Oil System

1. Long-Range Oil Tanks
2. Valve
3. Clark-Valve
4. Oil Cooler
5. Carburetor
6. Hydromatic Oil Pump
7. Constant Speed Unit (CSU)
8. Engine
9. Oil Separator
10. Valve

- Feed Low-Pressure Lines
- Return Low-Pressure Lines
- Feed High-Pressure Lines
- Return High-Pressure Lines
- Oil Dilution
- Purging

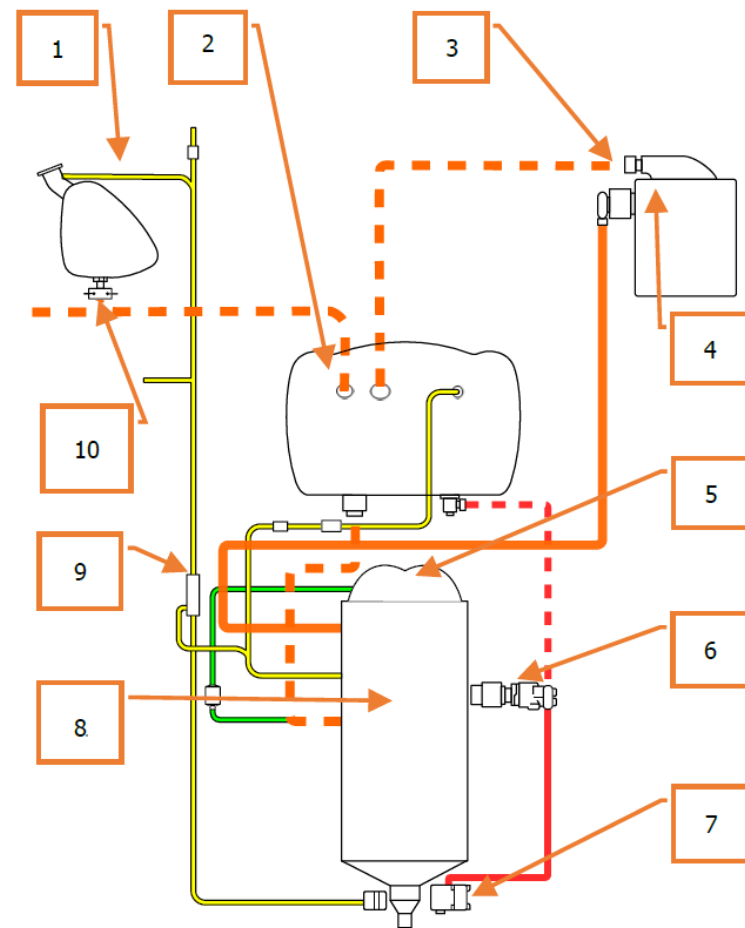

Oil System Schematic

ENGINE INDICATIONS

Here is an overview of the various engine indications you have to monitor:

- **Engine Tachometer (x100 RPM):** Controlled by the engine RPM lever. Indicates engine speed turning the constant speed propeller.
- **Boost Indicator (psi):** Similar to a Manifold Pressure indicator, Boost indicates the difference between the absolute pressure after the supercharger and the atmospheric pressure in psi. Positive boost values indicate a pressure higher than atmospheric pressure, while negative boost values indicate a pressure below atmospheric pressure. In ISA (standard) conditions, +0 Boost at sea level is roughly 14.7 psi, 760 mm Hg, 29.92 in Hg, 1013.25 mBar, or 101.325 kPa.
- **Radiator Coolant Temperature (deg C):** indicates the water-glycol coolant temperature. High coolant temperatures may indicate an engine setting that is too high or a perforated radiator leaking coolant.
- **Oil Temperature (deg C):** indicates the oil temperature in the engine lubrication system.
- **Oil Pressure Indicator (psi):** indicates the oil pressure of the engine lubrication system.
- **Low Fuel Pressure Warning Light:** indicates that there is an abnormally low fuel pressure (fuel tanks are empty or fuel pump is likely failed).

Tachometer (Left Engine)
Inner Needle: x1000 RPM
Outer Needle: x 100 RPM

Boost Indicator (psi) (Left Engine)
 • *Similar to manifold pressure*

Low Fuel Pressure Warning Light (Left Engine)

Oil Pressure Indicator (psi) (Left Engine)

Oil Temperature Indicator (deg C) (Left Engine)

Radiator Coolant Temperature Indicator (deg C) (Left Engine)

Tachometer (Right Engine)
Inner Needle: x1000 RPM
Outer Needle: x 100 RPM

Boost Indicator (psi) (Right Engine)
 • *Similar to manifold pressure*

Low Fuel Pressure Warning Light (Right Engine)

Oil Pressure Indicator (psi) (Right Engine)

Oil Temperature Indicator (deg C) (Right Engine)

Radiator Coolant Temperature Indicator (deg C) (Right Engine)

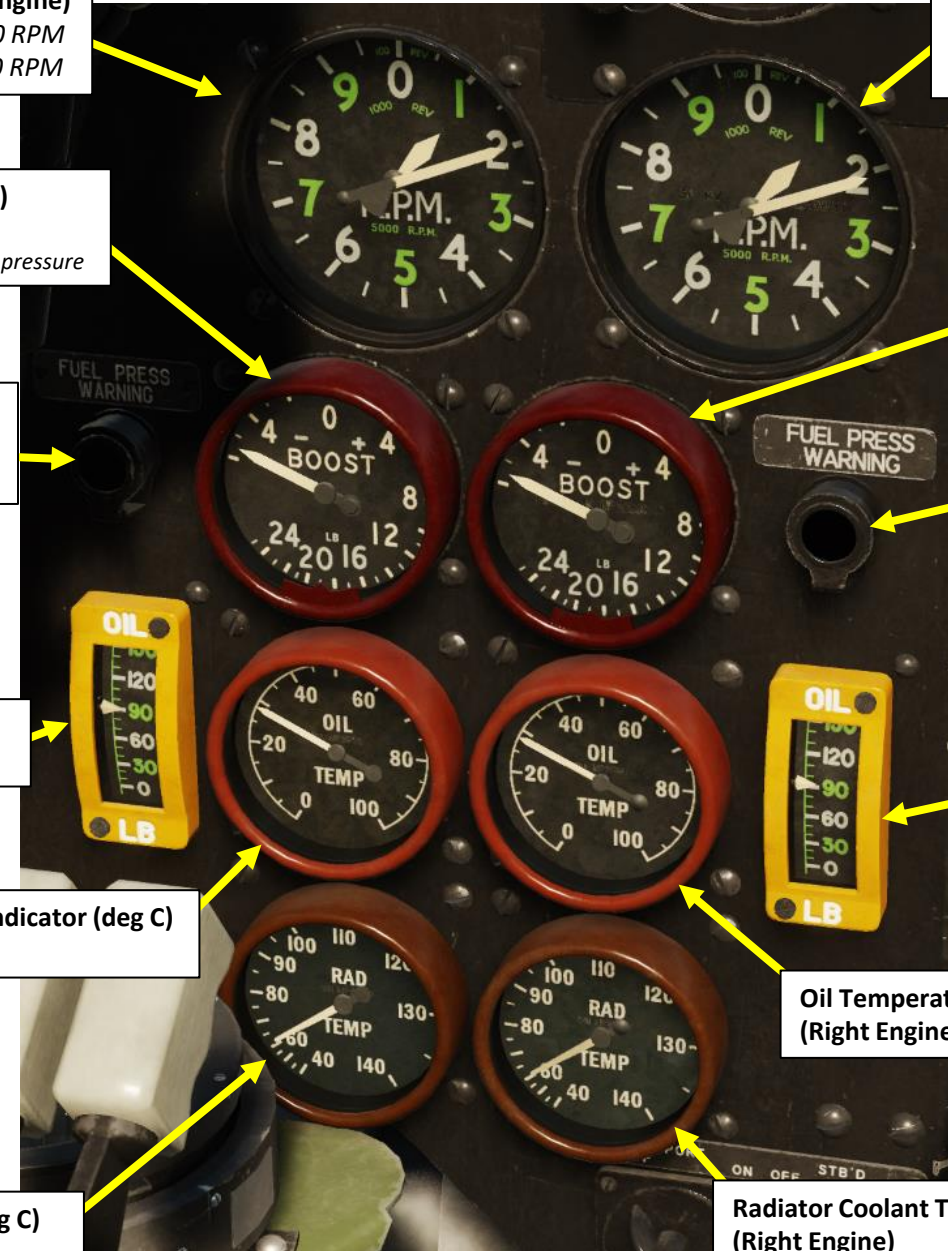

ENGINE CONTROLS

The main engine controls of the Mosquito are:

- **Throttle:** Controls boost pressure (manifold pressure). Normally the throttles can be pushed forward to the stops only. When the small catches on the levers are squeezed the throttles can be pushed fully forward. Merlin 25 engines give 4-12 lb./sq. in. boost at the stops and +18 lb./sq. in. when fully forward.
- **RPM Control Lever:** Controls engine speed turning the constant speed propeller.
- **Supercharger Gear Change Switch:** Controls manual or automatic gear shifting of the supercharger at high altitudes.
- **Boost Control Cut-Out Handle:** Not functional in Mosquito variants powered by the Merlin 25 (our variant). With Mosquito variants powered by the Merlin 23, this handle allows you to obtain additional boost (+14 psi in supercharger low gear).



Boost Control Cut-Out Handle

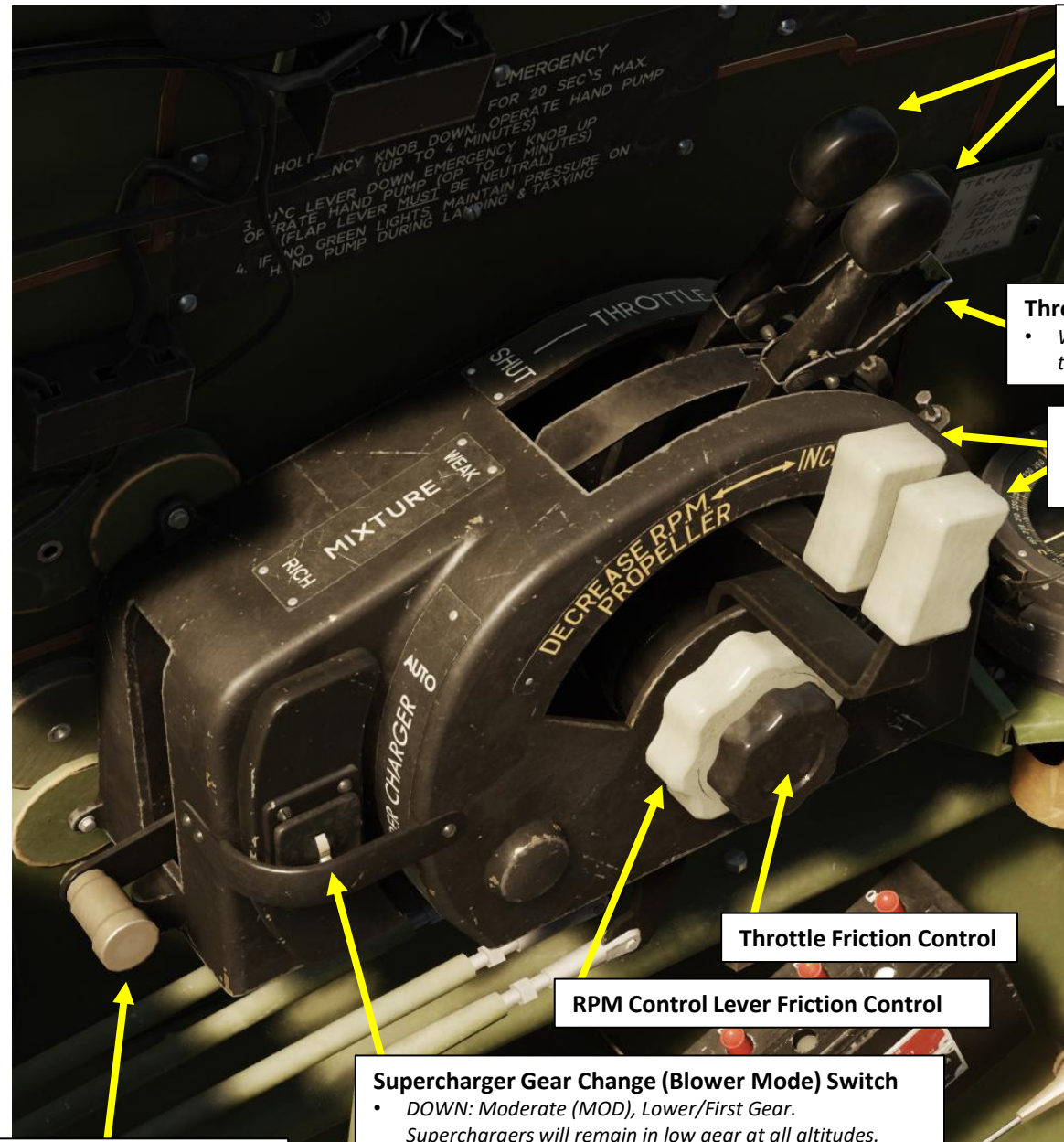

Throttle Levers
 • FWD: Increases Power
 • AFT: Decreases Power

Throttle "Catch" Trigger
 • When squeezed, allows throttle to be moved fully forward

RPM Control Levers
 • FWD: Increases RPM
 • AFT: Decreases RPM

Throttle Friction Control

RPM Control Lever Friction Control

Supercharger Gear Change (Blower Mode) Switch
 • DOWN: Moderate (MOD), Lower/First Gear. Superchargers will remain in low gear at all altitudes.
 • UP: Automatic mode. The electro-pneumatic rams/actuators are controlled by an aneroid, and will automatically engage high gear when climbing, at approximately 15000 ft.

Fuel Mixture Control Lever
 • DOWN: Rich Mixture.
 • UP: Weak Mixture

ENGINE CONTROLS

Throttle and RPM control levers can be mapped to specific axes if you have a throttle quadrant that has enough levers. However, most throttles available on the market only have up to 3 axes available.

For users that do not have 4 axes available, I suggest mapping the Engine RPM and Throttle axes on “Engine (selected) RPM” and “Throttle Engine (selected)”. This means that a single axis can control the lever of your choice.

Here is an example following this axis binding methodology:

- If you want to set a specific boost setting and RPM on the left engine, press “8” to select the left engine, then move the Throttle and RPM axes. Only the left throttle and RPM levers will be controlled.
- If you want to set a specific boost setting and RPM on the right engine, press “0” to select the right engine, then move the Throttle and RPM axes. Only the right throttle and RPM levers will be controlled.
- If you want to control both throttles and RPM levers at the same time, press “9” to select both engines, then move the Throttle and RPM axes. Both the left and right throttles and RPM levers will be controlled.

OPTIONS

SYSTEM	CONTROLS	GAMEPLAY	MISC.
Mosquito FB Mk. VI	All	<input checked="" type="checkbox"/> Foldable view	Reset category to default
Action	Category	Keyboard	
Select Active Engine to control - both	Engine Controls	9	
Select Active Engine to control - left (port)	Engine Controls	8	
Select Active Engine to control - right (starboard)	Engine Controls	0	

- “8” controls LEFT Engine
- “0” controls RIGHT Engine
- “9” controls BOTH Engines

CONTROL OPTIONS

SYSTEM	CONTROLS	GAMEPLAY	MISC.
Mosquito FB Mk. VI	Axis Commands	<input checked="" type="checkbox"/> Foldable view	Reset category to default
Action	Category		
Engine (selected) RPM / Propeller Pitch - axis	Engine Controls		
Engine RPM / Propeller Pitch, port - axis	Engine Controls		
Engine RPM / Propeller Pitch, starboard - axis	Engine Controls		
Throttle, engine (selected) - axis	Engine Controls		
Throttle, left engine - axis	Engine Controls		
Throttle, right engine - axis	Engine Controls		



ENGINE CONTROLS

Throttle travel is mechanically limited by a throttle “catch”. In real life, throttles are moved past the takeoff power detent by squeezing the throttle catch triggers while advancing the throttle.

DCS has throttle detent options that allows the triggers to be automatically squeezed to go past the detent, which I recommend you use. Hardcore users can use the “Depress triggers to lift locks”

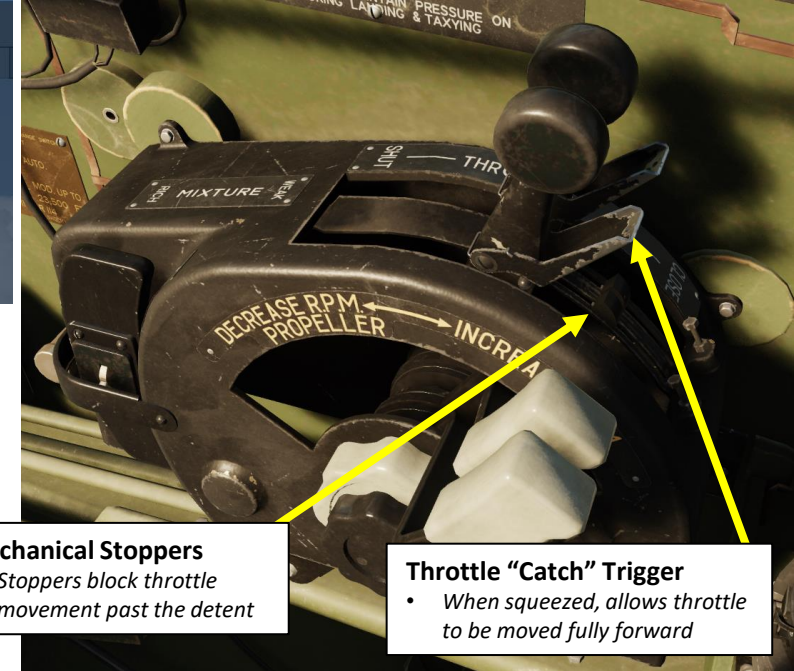

Mechanical Stoppers

- Stoppers block throttle movement past the detent

Throttle “Catch” Trigger

- When squeezed, allows throttle to be moved fully forward

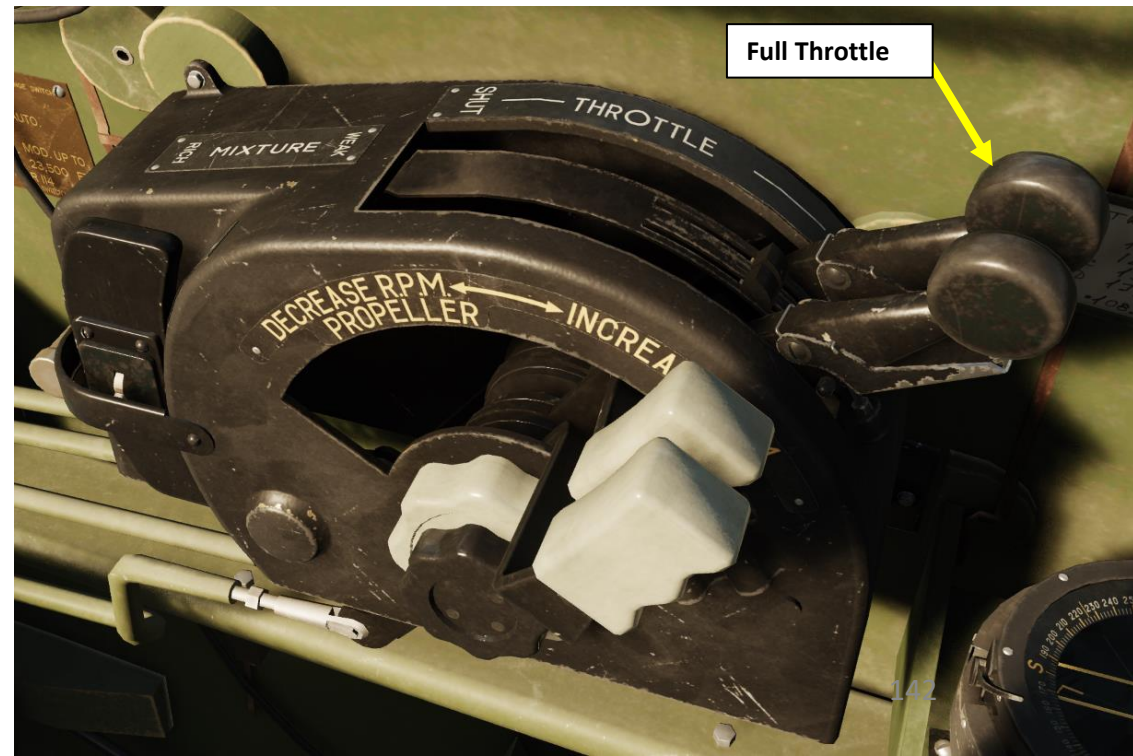
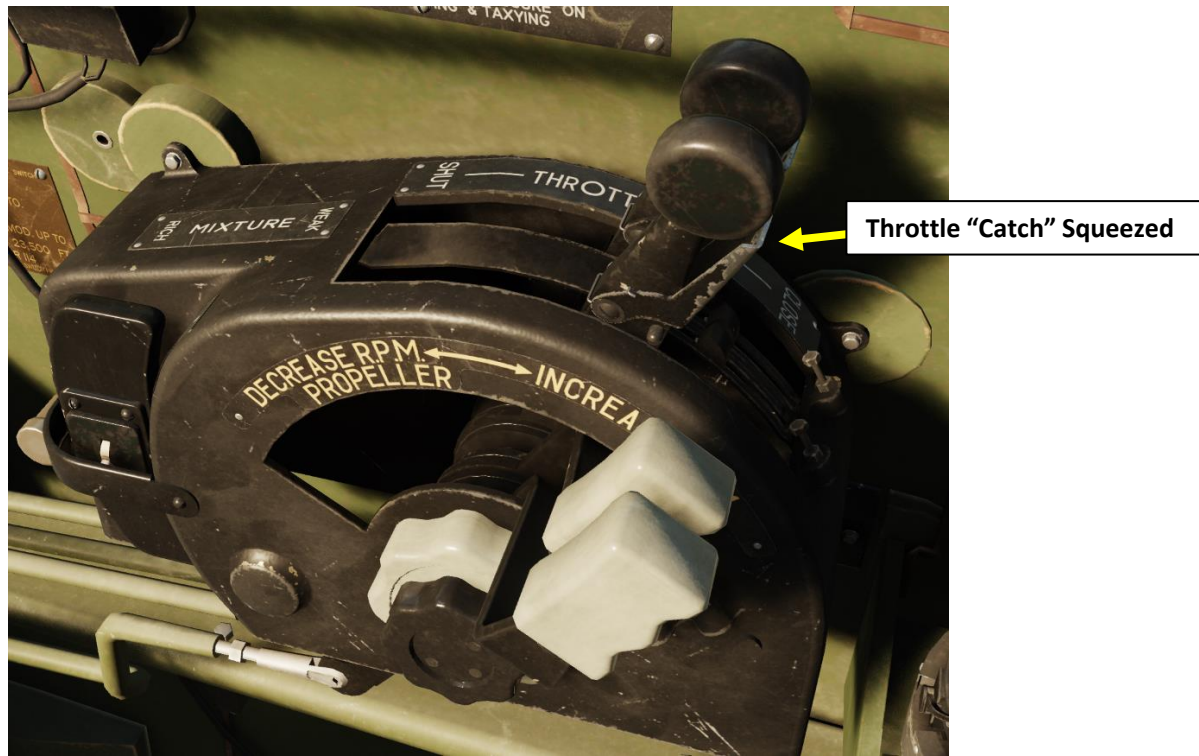

ENGINE CONTROLS

Here are additional engine controls of the Mosquito:

- Radiator Flaps Shutter Switches:** Opens (DOWN) or Closes (UP) radiator outlet flaps.
 - Note: It is not possible to set the shutters at intermediate positions between fully open and shut. There are no separate oil cooler controls. Electro-pneumatically operated radiator shutters are fitted at the rear of the combined engine coolant radiator and oil cooler, inboard of each engine. Airflow through the radiator ducts is controlled by these shutters which are operated by two-way switches. Thermostatic and viscosity valves in both coolant and oil cooler systems respectively, ensure rapid "warming up" to predetermined temperatures.
- Carburettor Air Intake Filter Control:** Controls damper covering passageway of the air intake to the carburetor. The Switch should only be ON (DOWN) when taking off or taxiing in a dusty environment.
 - UP (OFF): Normal Intake (Damper is Open).
 - DOWN (ON): Filter In Operation (damper is shut and air comes from the engine compartment).

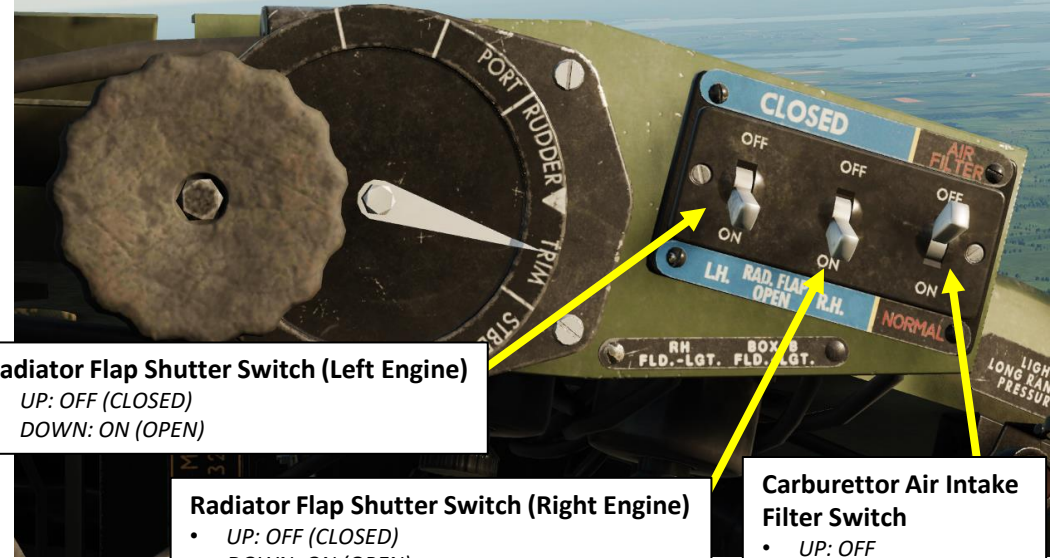

Radiator Flap Shutter Switch (Left Engine)

- UP: OFF (CLOSED)
- DOWN: ON (OPEN)

Radiator Flap Shutter Switch (Right Engine)

- UP: OFF (CLOSED)
- DOWN: ON (OPEN)

Carburettor Air Intake Filter Switch

- UP: OFF
- DOWN: ON

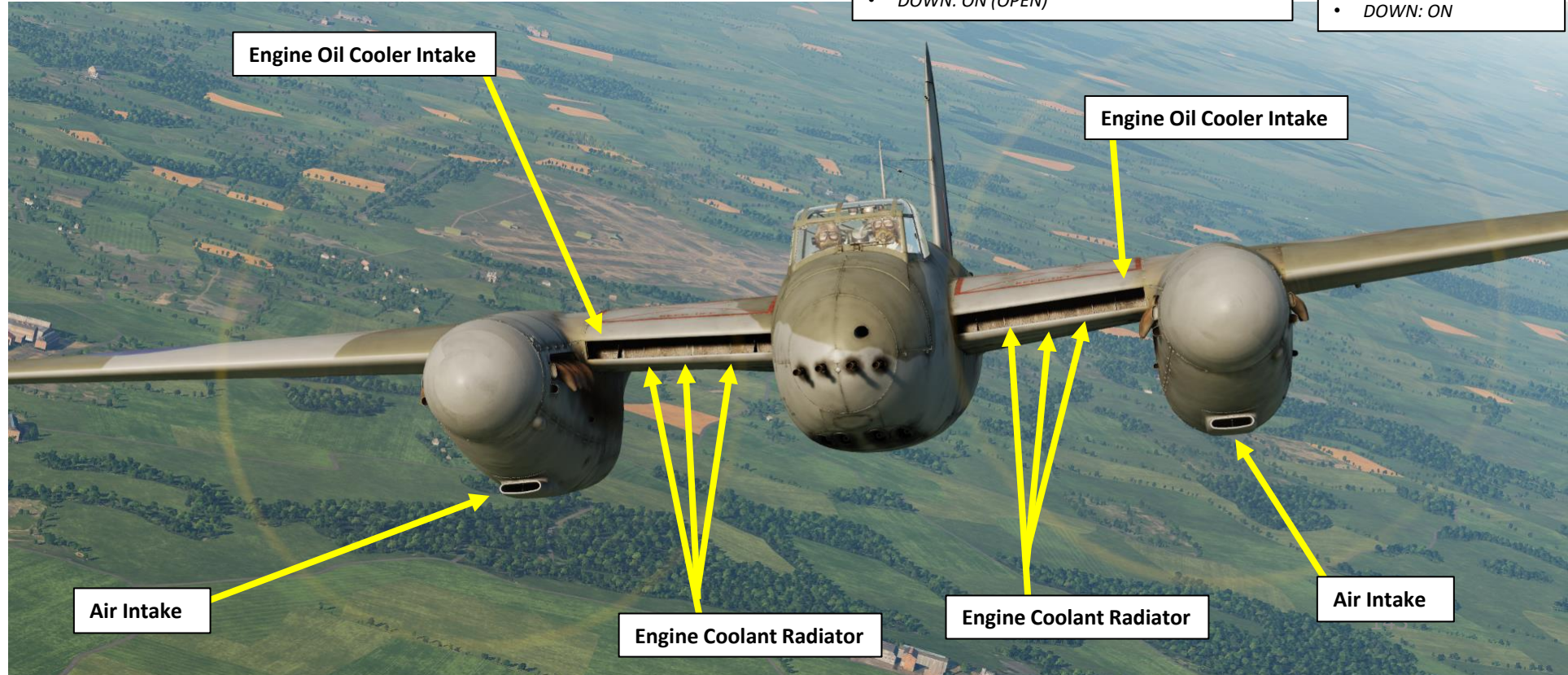

Engine Oil Cooler Intake

Engine Oil Cooler Intake

Air Intake

Engine Coolant Radiator

Engine Coolant Radiator

Air Intake

ENGINE CONTROLS

Here are some general rules for **Flap Shutter Settings**:

- **On Takeoff:** Flap Shutters OPEN (Switch DOWN).
- **On Approach/Landing:** Flap Shutters OPEN (Switch DOWN).
- **When Flying Level:** As required; CLOSED to minimize drag, OPEN to keep coolant temperatures in check (normal operation).
- **When Climbing:** Flap Shutters OPEN (Switch DOWN) to avoid overheating.
- **When Diving:** Flap Shutters CLOSED (Switch DOWN) to avoid overcooling.
- **When Feathering an Engine:** Flap Shutter of affected (feathered) engine CLOSED (Switch UP) to minimize aerodynamic drag.

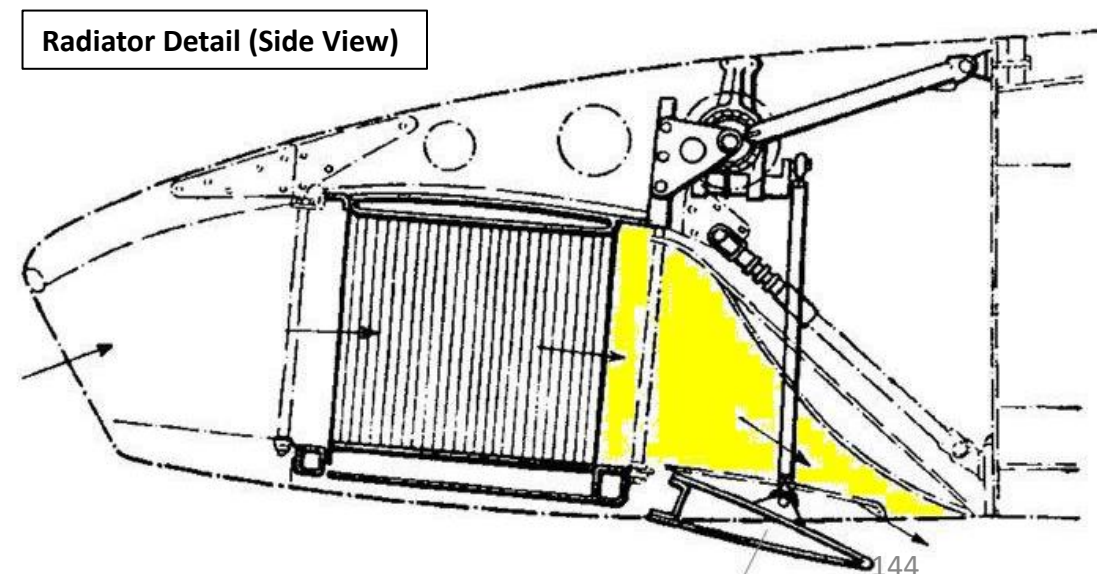
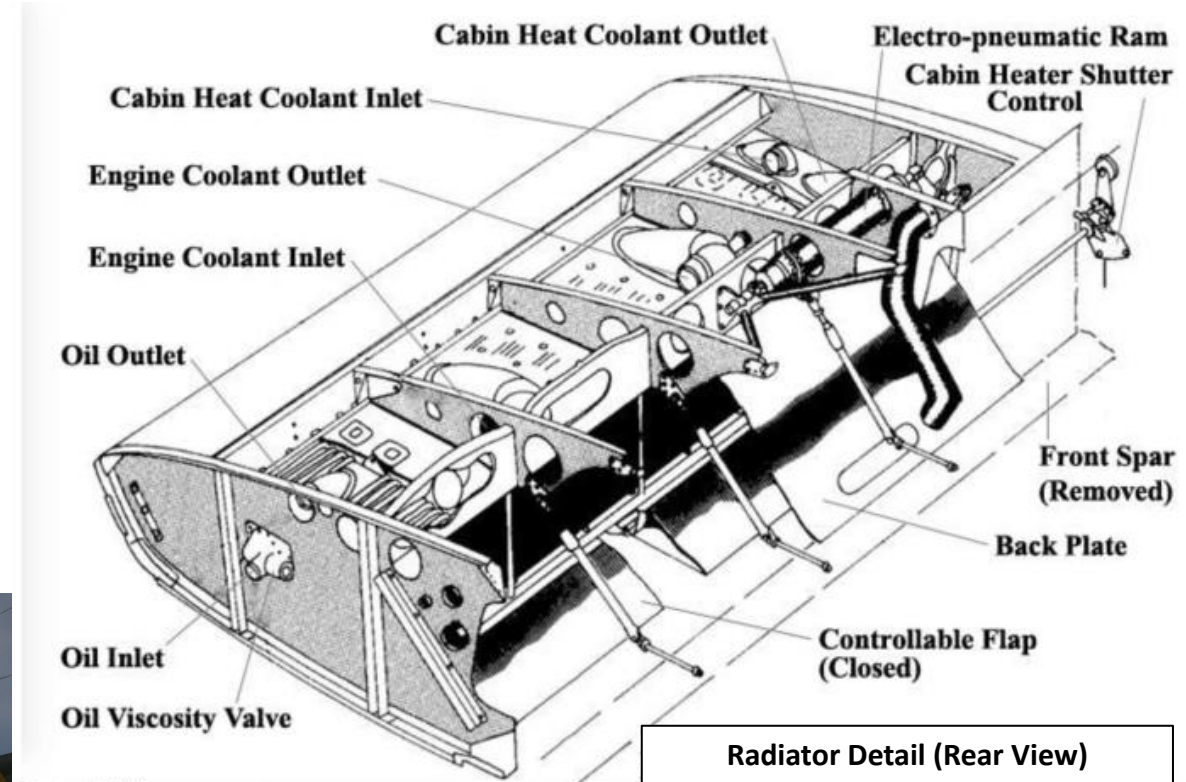
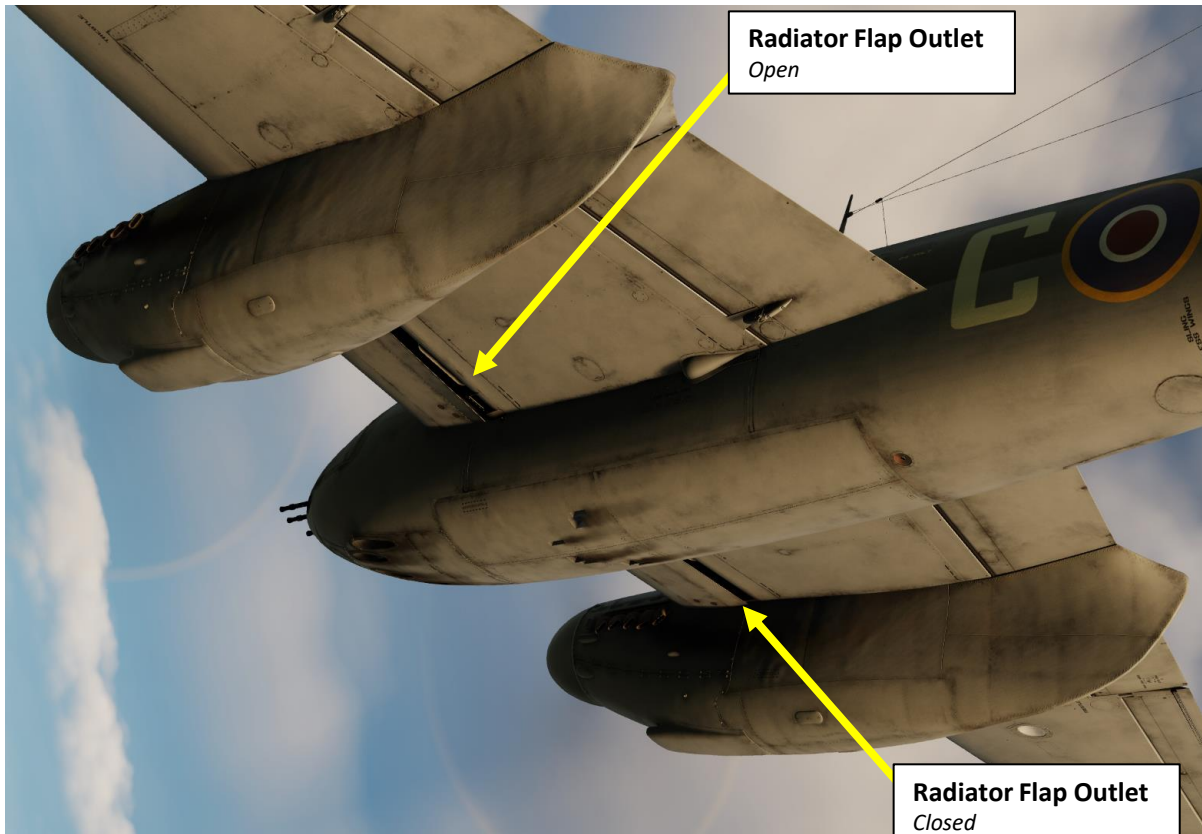

Flap Regulates Airflow (Airflow represented in Yellow)



ENGINE CONTROLS

The oil system uses standard air force **oil dilution** equipment. This allows the oil to be thinned with gasoline to make the engine easier to start in ambient temperatures below 40°F or 4°C.

Thinning the oil requires allowing the engine to idle with the coolant flap open until the oil temperature drops to 50°C or less. Then, before stopping the engine, oil is diluted using the Dilution buttons behind the pilot seat. This will dilute the oil until the engine is ready to be started again. Once the engine warms up, the gasoline in the oil is quickly evaporated.

To ensure a cold start at the following temperatures, the oil should be diluted for the times quoted below:

- Between -10 deg C and -15 deg C: 1 minute
- Between -15 deg C and -26 deg C: 2 minutes

During the next start after 2 minutes dilution, the minimum partial boiling-off period at 2000 RPM is 10 minutes. After 1 minute dilution, no special partial boiling-off precautions are necessary.

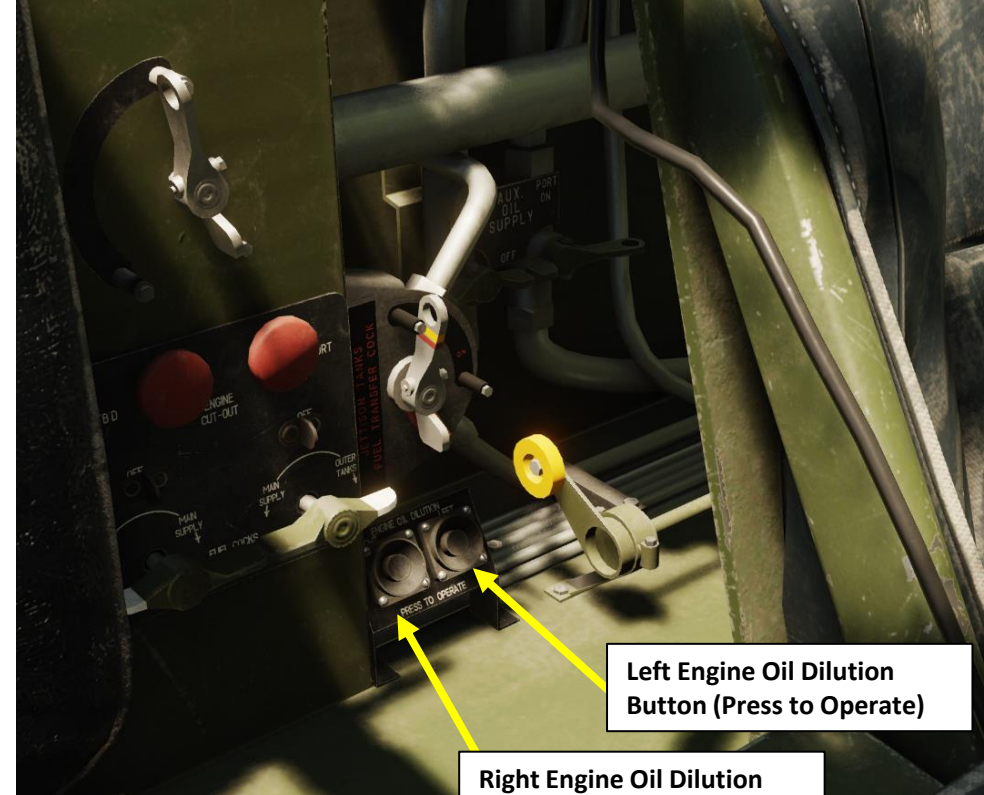

Left Engine Oil Dilution Button (Press to Operate)

Right Engine Oil Dilution Button (Press to Operate)



ENGINE OPERATION & LIMITS

If engine overheats, you can:

1. Enter a dive to increase airspeed and airflow to the engine intake.
2. Reduce throttle and RPM
3. Decrease rate of climb
4. Set the Radiator Flap Shutter switch to ON (will open the radiator flap).

CHECK YOUR ENGINE TEMPERATURES EVERY 30 SECONDS OR SO. IT WILL SAVE YOUR LIFE.

MERLIN 25 ENGINE SETTINGS & LIMITS					
<u>100 OCTANE FUEL</u>					
Power Setting	RPM	Supercharger Gear	Boost (psi)	Coolant Temperature (deg C)	Oil Temperature (deg C)
Operational Necessity / Emergency Power (5 min limit)	3000	Low/High	+18 (may not be used at RPM below 2850)	Maximum: 135	Maximum: 105
Max Take-Off	3000	Low	+18 (may not be used at RPM below 2850)	-	-
Max Climbing Power (1 hour limit)	2850	Low/High	+9	Maximum: 125	Maximum : 90
Max Continuous	2650	Low/High	+7	Maximum: 105 (115 may be used for short periods only)	Maximum: 90
Minimums					
Oil Pressure (psi)	Minimum in Flight: 30 psi				
Oil Temperature (deg C)	Minimum for Takeoff: 15 deg C				
Coolant Temperature (deg C)	Minimum for Takeoff: 40 deg C				

ENGINE OPERATION & LIMITS

MERLIN 25 ENGINE FUEL CONSUMPTION <u>100 OCTANE FUEL</u>				
Power Setting	RPM	Mixture	Boost (psi)	Fuel Consumption (gal/hour per engine)
Operational Necessity / Emergency Power (5 min limit)	3000	Rich	+18 (may not be used at RPM below 2850)	-
Max Take-Off	3000	Rich	+18 (may not be used at RPM below 2850)	-
Take-Off	3000	Rich	+12	115
Max Climbing Power (1 hour limit)	2850	Rich	+9	95
Max Continuous	2650	Rich	+7	80
	2650	Weak (Lean)	+7	63
	2300	Weak (Lean)	+2	42

SUPERCHARGER BASICS

A supercharger is an engine-driven air pump or compressor that provides compressed air to the engine to provide additional pressure to the induction air so the engine can produce additional power. It increases manifold pressure and forces the fuel/air mixture into the cylinders. The higher the manifold pressure, the more dense the fuel/air mixture, and the more power an engine can produce.

With a normally aspirated engine, it is not possible to have manifold pressure higher than the existing atmospheric pressure. A supercharger is capable of boosting manifold pressure above 30 "Hg. For example, at 8,000 feet a typical engine may be able to produce 75 percent of the power it could produce at mean sea level (MSL) because **the air is less dense at the higher altitude.** The supercharger compresses the air to a higher density allowing a supercharged engine to produce the same manifold pressure at higher altitudes as it could produce at sea level.

Thus, an engine at 8,000 feet MSL could still produce 25" Hg of manifold pressure whereas without a supercharger it could produce only 22 "Hg. Superchargers are especially valuable at high altitudes (such as 18,000 feet) where the air density is 50 percent that of sea level. The use of a supercharger in many cases will supply air to the engine at the same density it did at sea level. With a normally aspirated engine, it is not possible to have manifold pressure higher than the existing atmospheric pressure.

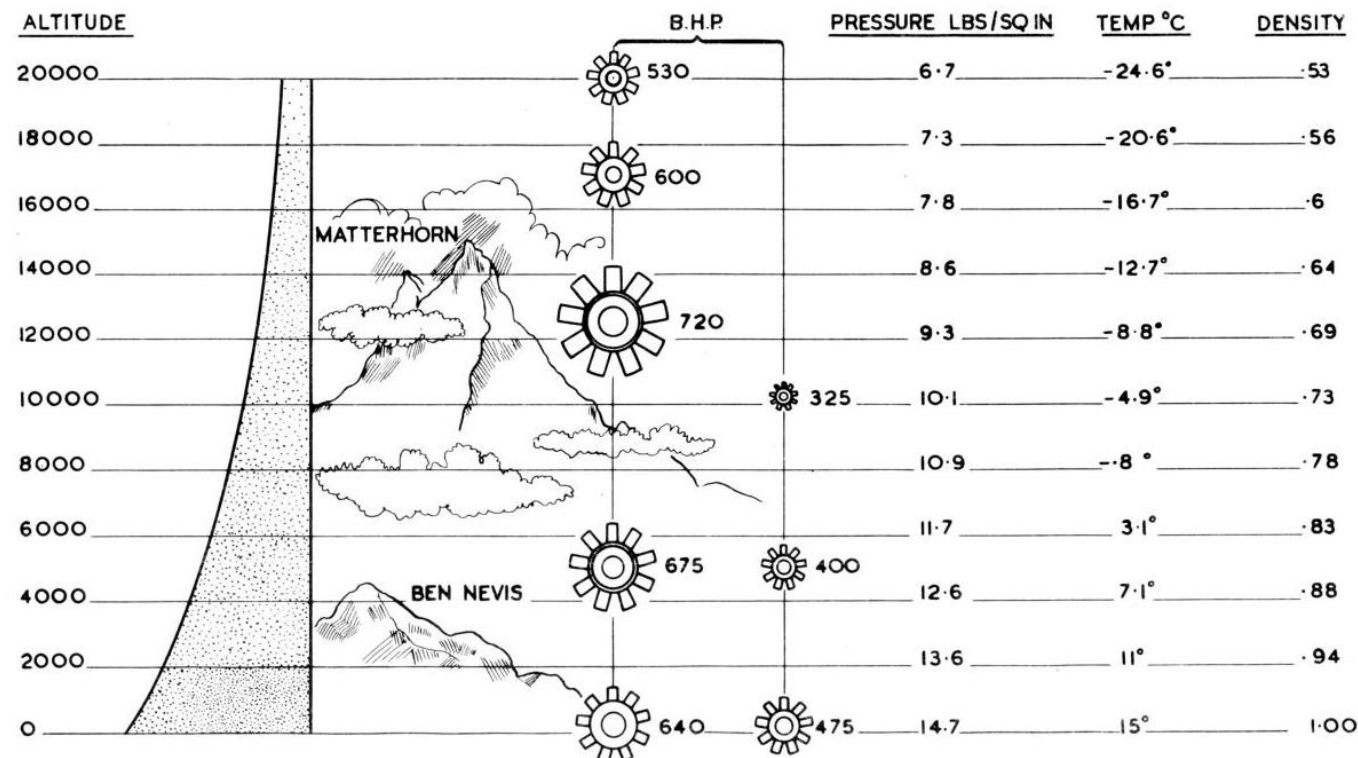
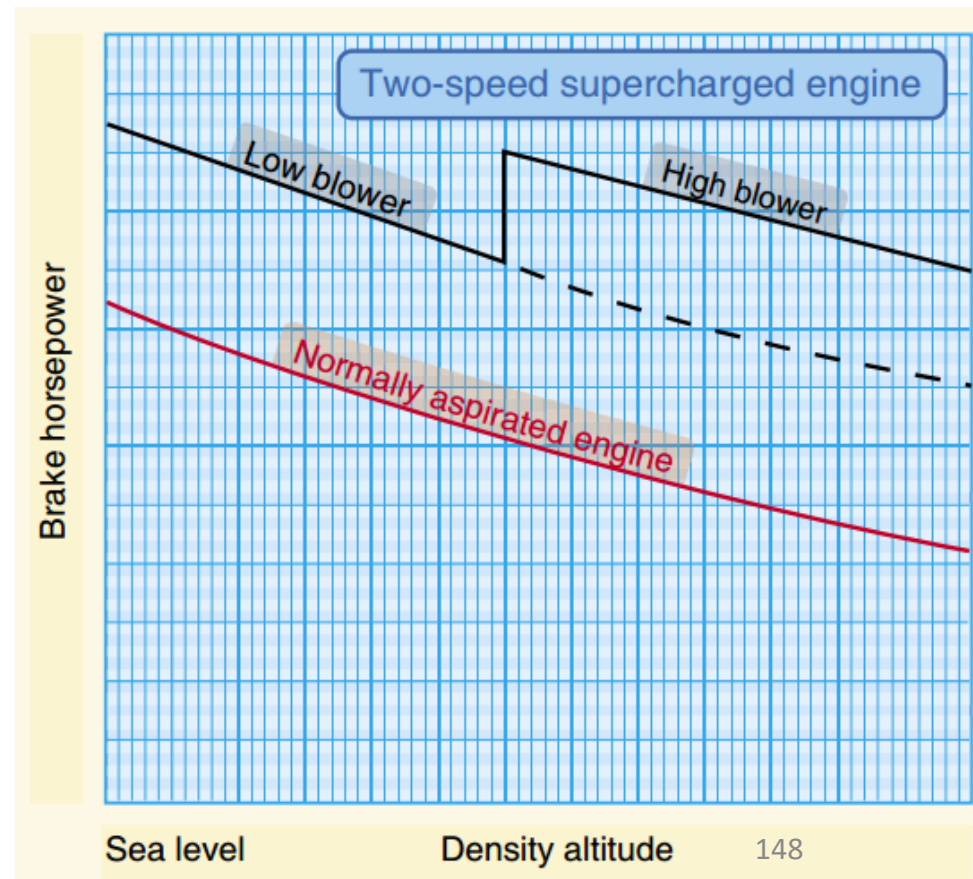

DIAGRAM SHOWING ATMOSPHERIC AND POWER VARIATIONS



Sea level

Density altitude

148

SUPERCHARGER OPERATION

The Merlin 25 engine is optimized for low altitude flight. However, the Merlin has a two-speed, single-stage, liquid-cooled, high-speed centrifugal type supercharger, which is driven from the rear end of the crankshaft through a two-speed gearbox. The supercharger raises air pressure at the entrance to the engine cylinders in order to increase both the coefficient of admission and engine power, as well as to maintain a constant air pressure at the entrance to the cylinders during increases in altitude. The supercharger works in either low or high blower mode, selection of which can be automatic or manually set by the pilot. In normal operations, high blower mode starts automatically from 15,000 feet, depending on the amount of ram air being delivered through the carburetor.

Shifting between the first gear "MOD." (moderate supercharger) and second gear speeds may be performed automatically if the Supercharger Gear Change switch in the cockpit is left in the AUTO (UP) position, or manually if set to MOD (DOWN), forcing the supercharger in first gear. When operating under 15,000 ft (or when maximum achievable boost is over +7 psi), the supercharger is typically left to MOD. Why? Because the throttles are very sensitive and the supercharger high gear may not necessarily kick in exactly at the same time for both engines if flying close to the pressure-altitude threshold. In order to avoid having the engines switch gear at different times (which can create an offset between engine boost, causing a torque differential that can potentially be dangerous), it is preferable to set the Automatic mode once you are sure both engines will switch to the high blower simultaneously; basically, when you are at a safe altitude to do so, which is above 15000 ft.

First Gear = Low Blower = Low Manifold Pressure = used between 0 and 15000 ft
Second Gear = High Blower = High Manifold Pressure = used at 15000 ft or higher

MOD. (Moderate Supercharger Setting) Mode Active
Altitude: 19000 ft



Supercharger Gear Change Switch – DOWN (MOD)
MOD. (Moderate Supercharger Setting) Mode
(Low/First Gear when over 15,000 ft)

Automatic Mode Active
Altitude: 19000 ft



Supercharger Gear Change Switch – UP (AUTO)
Supercharger in Automatic Mode
(High/Second Gear when over 15,000 ft)

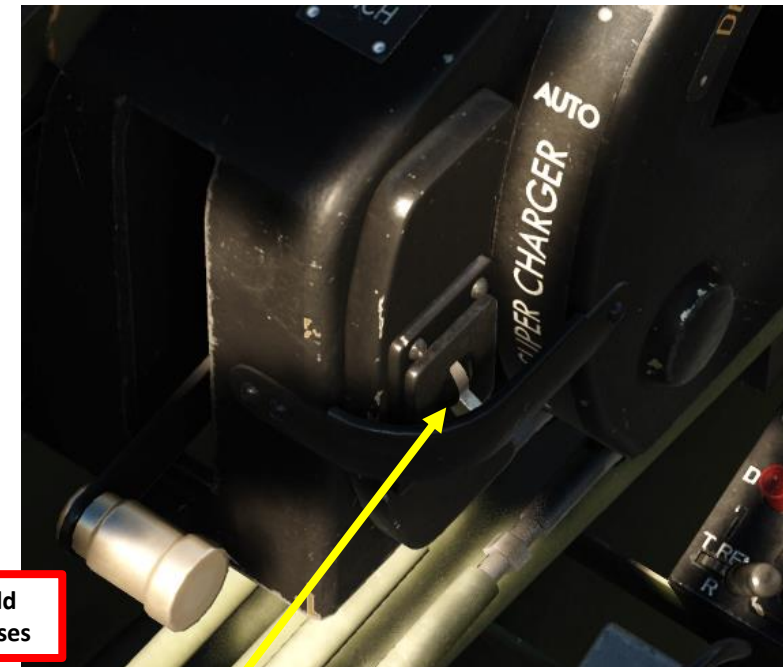

Supercharger Gear Change (Blower Mode) Switch

- *DOWN: Moderate (MOD), Lower/First Gear. Superchargers will remain in low gear at all altitudes.*
- *UP: Automatic mode. The electropneumatic rams/actuators are controlled by an aneroid, and will automatically engage high gear when climbing, at approximately 15000 ft.*

PROPELLER FEATHERING/UNFEATHERING SYSTEM

During normal engine operation, the angle of each propeller is automatically adjusted by the CSU (Constant Speed Unit) governor in order to maximize generated thrust while maintaining a constant engine RPM.

In case of an engine failure, the CSU (Constant Speed Unit) will likely lose control over the propeller blade angle, leaving the propeller at a high angle of attack. At low airspeeds, having the propeller at a “fine” (high) blade angle can generate a significant amount of drag, which can be very dangerous at low speeds (below 180 mph) since it creates a moment that can send the aircraft in a violent, unrecoverable spin. This is why a “feathering” system exists; an oil pump pushes oil into the Constant Speed governor mechanism to turn the blade into a “**feathered**” position (where the blade angle is “fully coarse”, minimizing drag in the process). Stopped blades twist to nearly align with the slipstream and no longer present a disc to the relative wind.

The propeller can also be “**unfeathered**”, which uses the same oil pump to turn the blade in the other direction towards a “fine” angle. This is useful in cases where aircraft speed is high and the speed of the air can generate enough force on the propeller blades to turn them (windmilling). When unfeathering the propeller, you can try to use windmilling to try to restart the engine and make the Constant Speed Unit governor take over the propeller blade angle control.

Keep in mind that if an engine is damaged due to anti-aircraft artillery or other factors, it is quite possible that the oil pump system that drives the blade angle may be inoperative as well. This will prevent you from being able to either feather or unfeather the propeller.

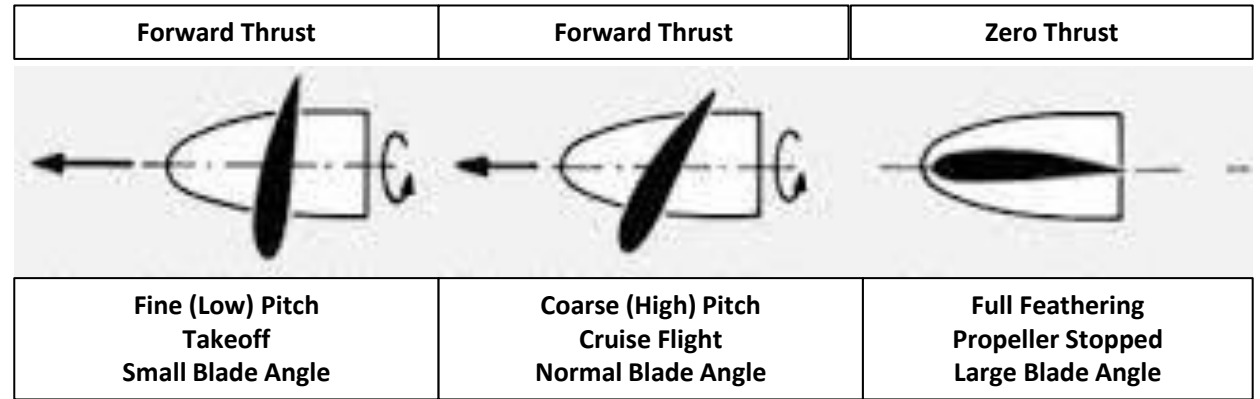

Feathering Button (Left Propeller)

- Feathers propeller to reduce drag when engine is shut down while in-air

Feathering Button (Right Propeller)

- Feathers propeller to reduce drag when engine is shut down while in-air





PROPELLER FEATHERING/UNFEATHERING SYSTEM

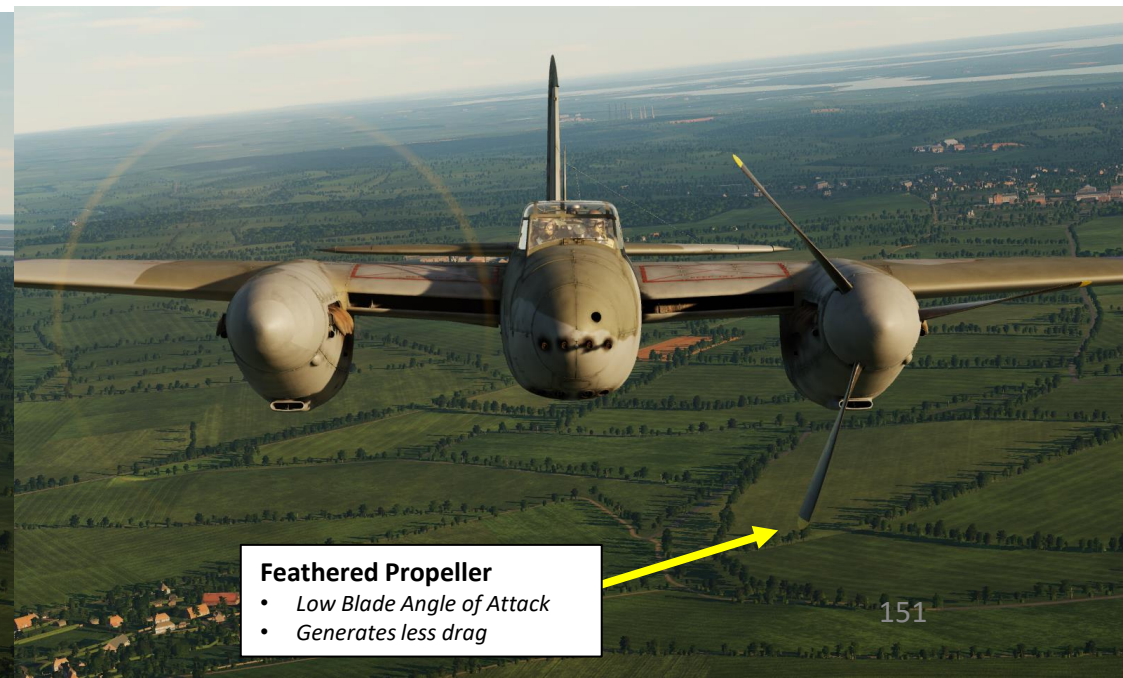
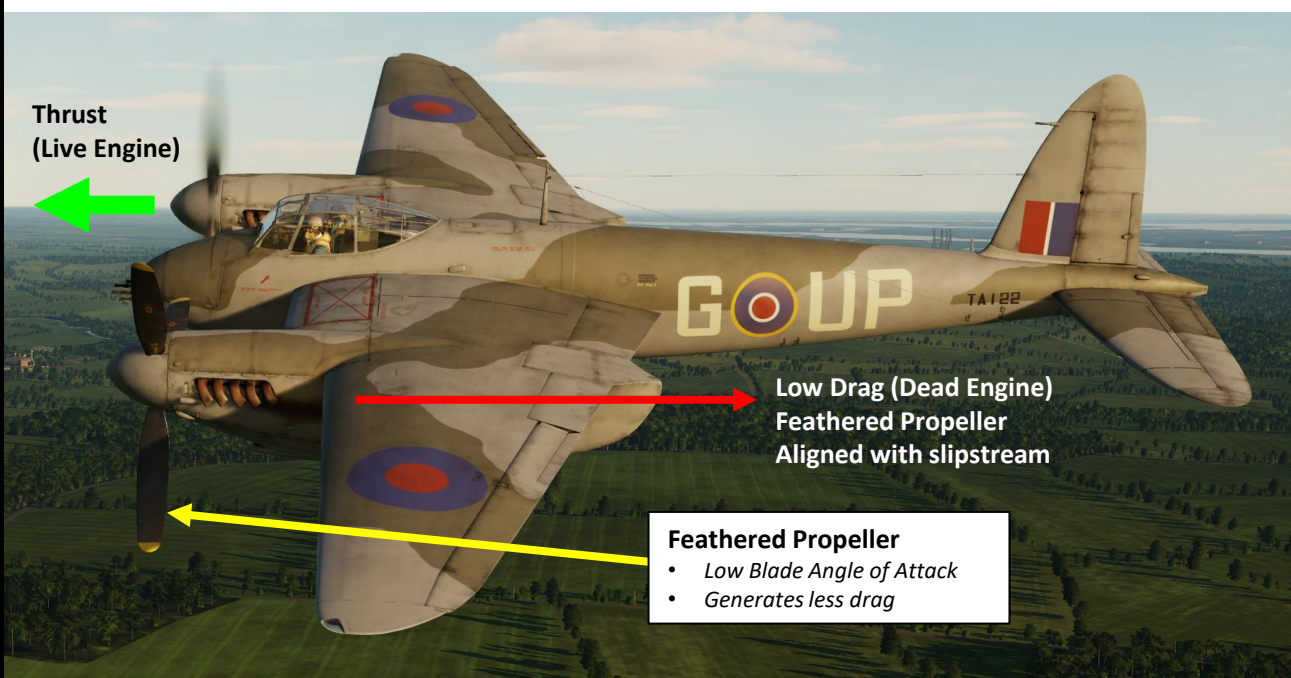
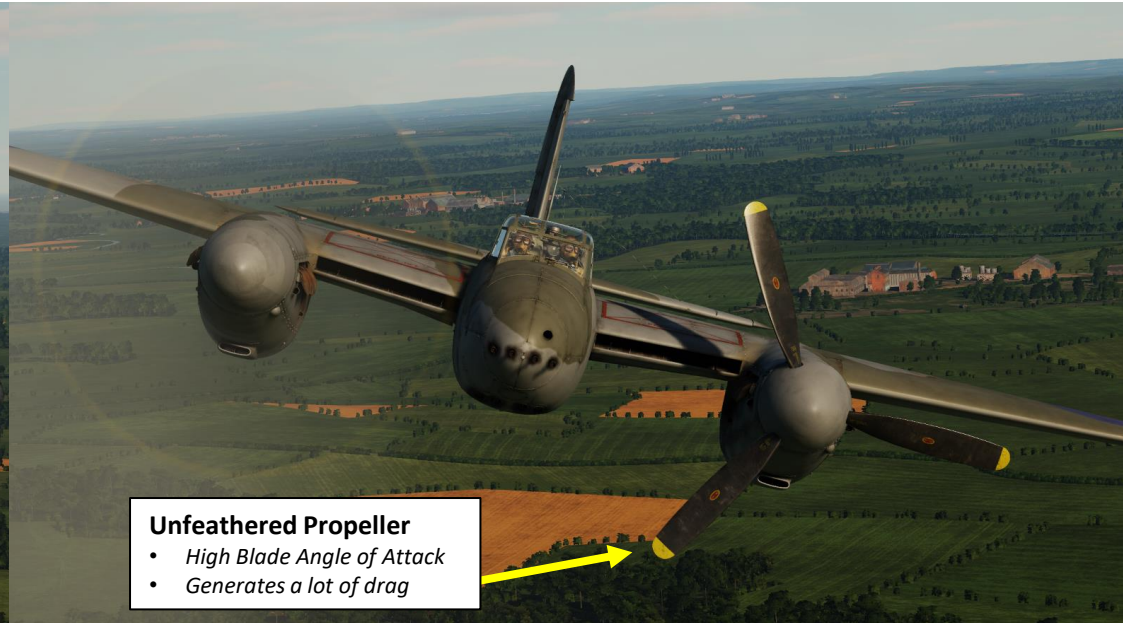
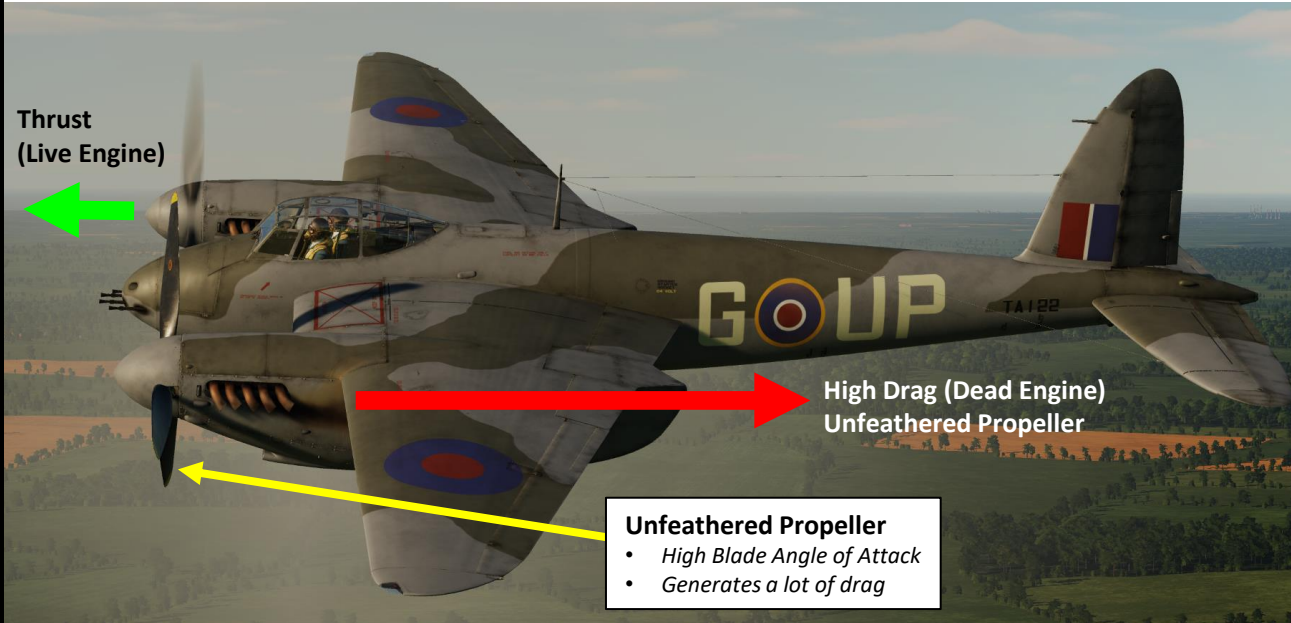



PROPELLER FEATHERING PROCEDURE

To feather a propeller:

1. Close the throttle
2. Set the Throttle and RPM Lever of the affected engine FULLY AFT.
3. Hold the feathering pushbutton in only long enough to ensure that it stays in by itself, then release it so that it can spring out when the feathering is complete. If it does not spring out, it must be pulled out.
4. Turn off the fuel cock.
5. When the engine has stopped, or nearly stopped, switch off the ignition (Magneto Switches) and close the radiator shutter.

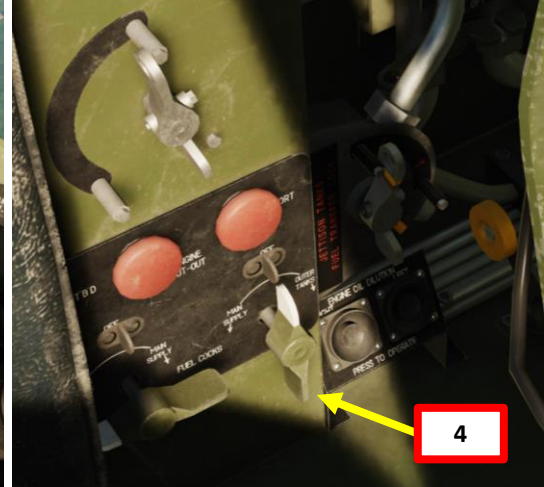



PROPELLER UNFEATHERING PROCEDURE

To unfeather a propeller:

1. Set throttle slightly open and the RPM control lever fully AFT, and then switch on the ignition (Magneto Switches).
2. Hold the feathering pushbutton in until RPM rises to 800-1000 and ensure that it springs out fully.
3. Turn on the fuel cock.
4. If the propeller does not return to normal constant-speed operation, it must be feathered and unfeathered again, releasing the feathering pushbutton at a slightly higher RPM.
5. It is advisable to unfeather at speeds below 200 mph to avoid risk of engine overspeeding.
6. Idle the engine at approximately 1800 RPM until the temperatures reach the minimum for opening up the throttle to cruise power.

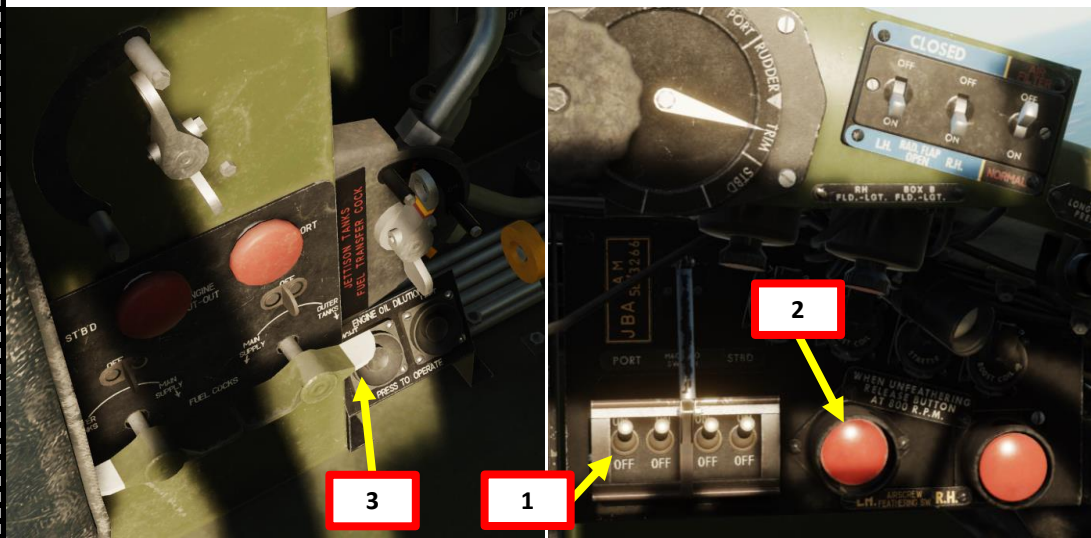



ENGINE FIRE EXTINGUISHERS

The Mosquito is equipped with Graviner fire extinguishers, which are fitted in each engine nacelle. If an engine fire is detected during flight, flip the safety cover and press the Fire Extinguisher pushbutton of the burning engine. A chemical agent will be released to extinguish the engine fire. Fire extinguishers operate automatically in the event of a crash.

Note: The Mosquito being made mostly of wood, the aircraft can burn up very quickly. If the fire extinguisher does not work, immediately open the side door and bail out as soon as possible.



FUEL SYSTEM OVERVIEW

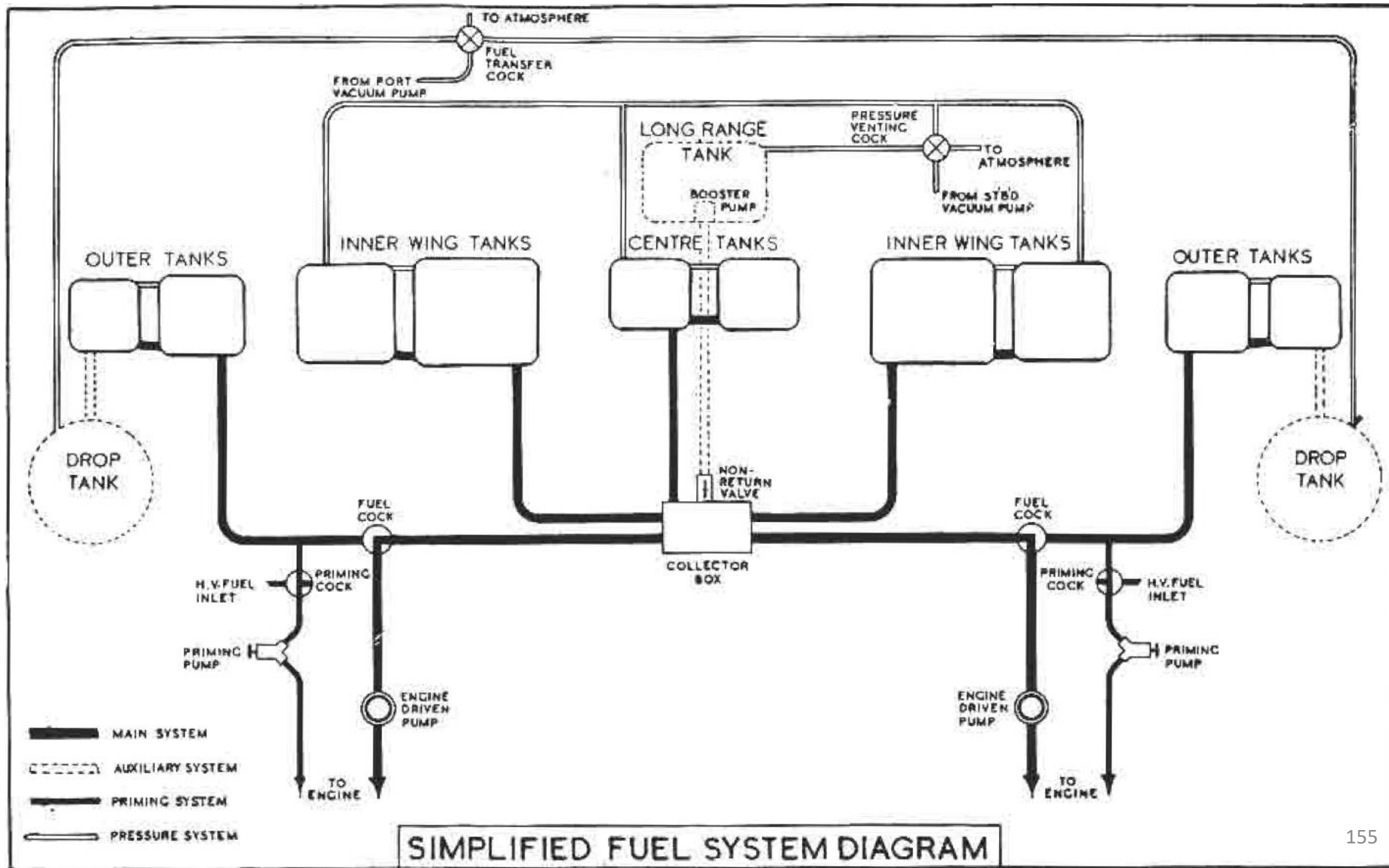

FUEL SYSTEM COMPONENTS

Fuel is contained in five pairs of CIMA protected aluminum alloy tanks, all of which are housed within the wing. The fuel in the external drop tanks is transferred to the outer tanks by air pressure supplied from the port vacuum pump, the control for which is on the left side of the observer adjacent to the main fuel cocks

A long-range tank can be carried in the 20 mm cannon bay aft of the machineguns. The contents of this tank are pumped to the fuel gallery by an immersion pump, controlled by a switch in the cockpit. The fuel pump unit, mounted on the left side of the wheel housing, consists of two separate pumps operating in parallel. Each pump can operate independently of the other, and each pump has sufficient capacity to deliver more than the required maximum amount of fuel.

A Ki-gass priming pump is fitted at each engine nacelle and is accessible through a hinged flap on the right-hand side. The Ki-gass pumps draw fuel from the outer wing tanks via a three-way cock next to the pump, alternatively, high volatility fuel can be pumped from a separate container.

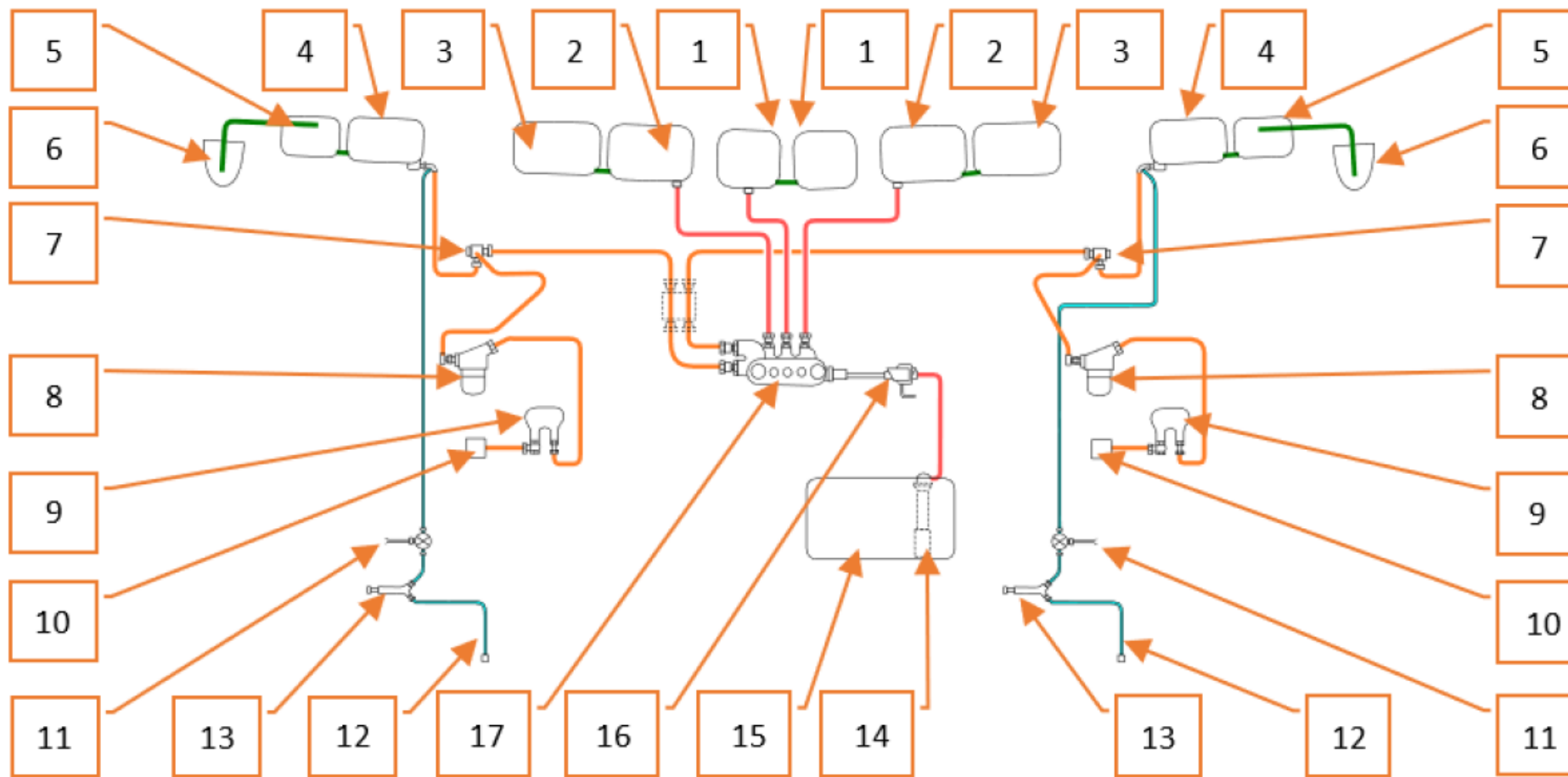

- | | |
|-----|---------------------------------|
| 1. | 25 Gallons Fuel Tank |
| 2. | 78 Gallons Fuel Tank |
| 3. | 65 Gallons Fuel Tank |
| 4. | 34 Gallons Fuel Tank |
| 5. | 24 Gallons Fuel Tank |
| 6. | External Drop Tank |
| 7. | 4-way Switch |
| 8. | Fuel Filter |
| 9. | Fuel Pump |
| 10. | Carburetor |
| 11. | External Fuel Supply |
| 12. | Connection to the Supercharger |
| 13. | Ki-gass Pump |
| 14. | Immersed Fuel Pump |
| 15. | 63 Gallons Long-Range Fuel Tank |
| 16. | Non-Return Valve |
| 17. | Fuel Collector Box |

FUEL SYSTEM COMPONENTS

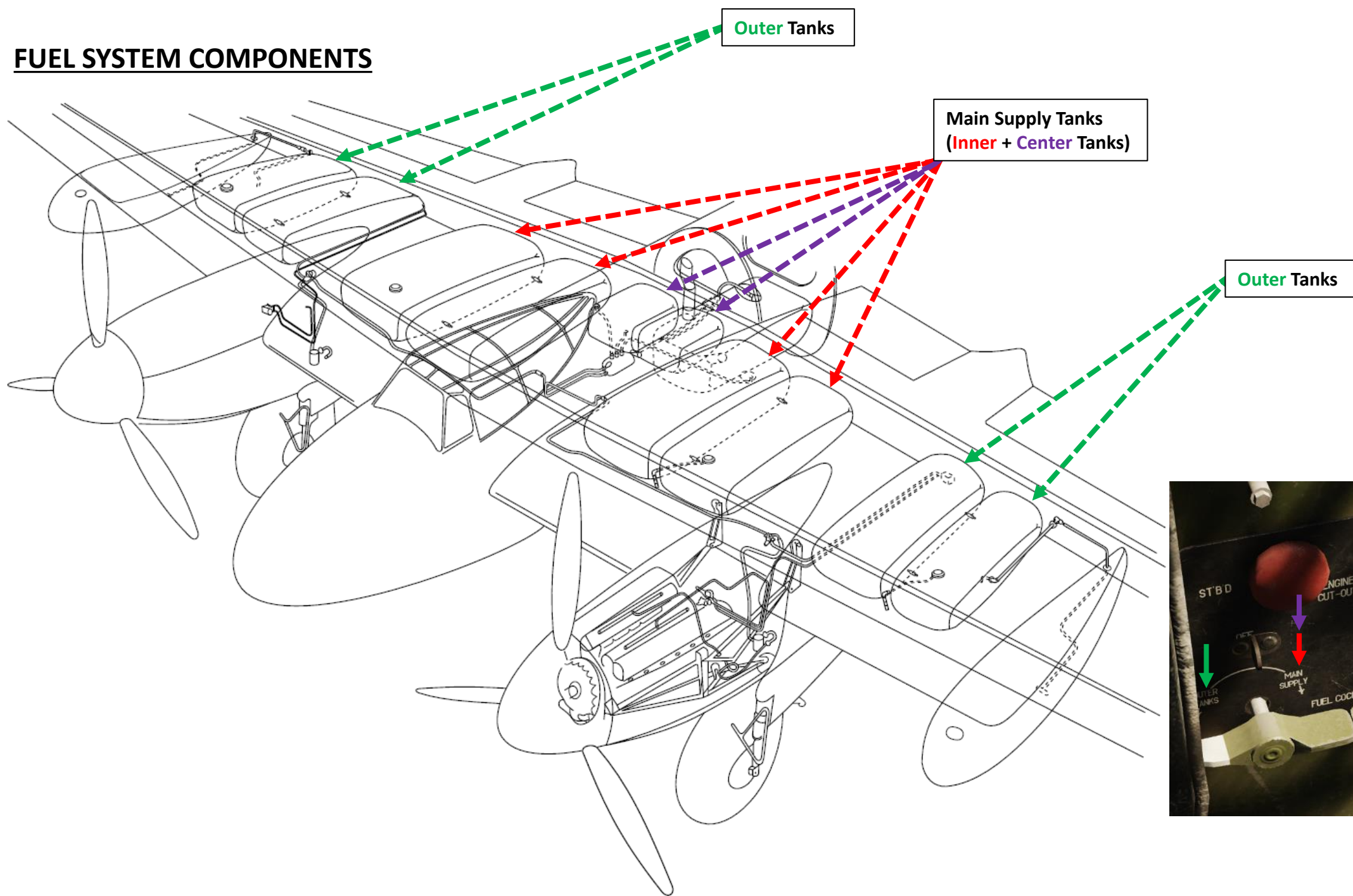



FUEL SYSTEM COMPONENTS

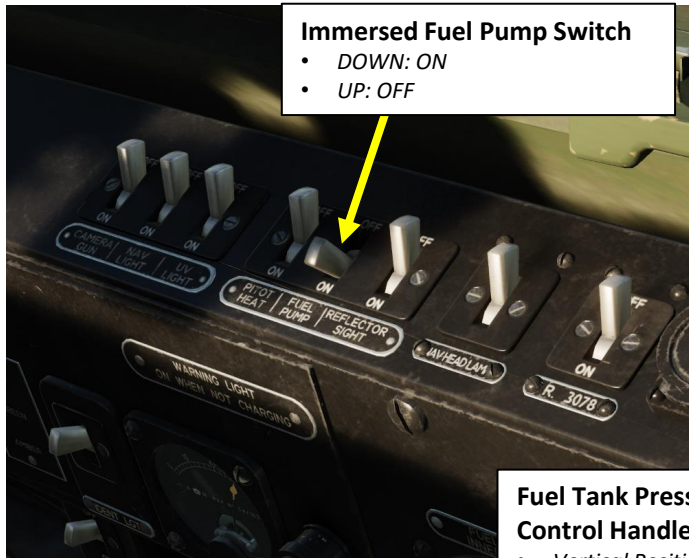

Immersed Fuel Pump Switch
• DOWN: ON
• UP: OFF



External Wing Fuel Tank Jettison Button
Flip safety cover, then press button to jettison external wing fuel tanks



Low Fuel Pressure Warning Light (Left Engine)

Low Fuel Pressure Warning Light (Right Engine)

Fuel Tank Pressurization (Fuel Venting Cock) Control Handle
• Vertical Position (Shown): Fuel Pressurization ON.
• Horizontal Position: Fuel Pressurization OFF.

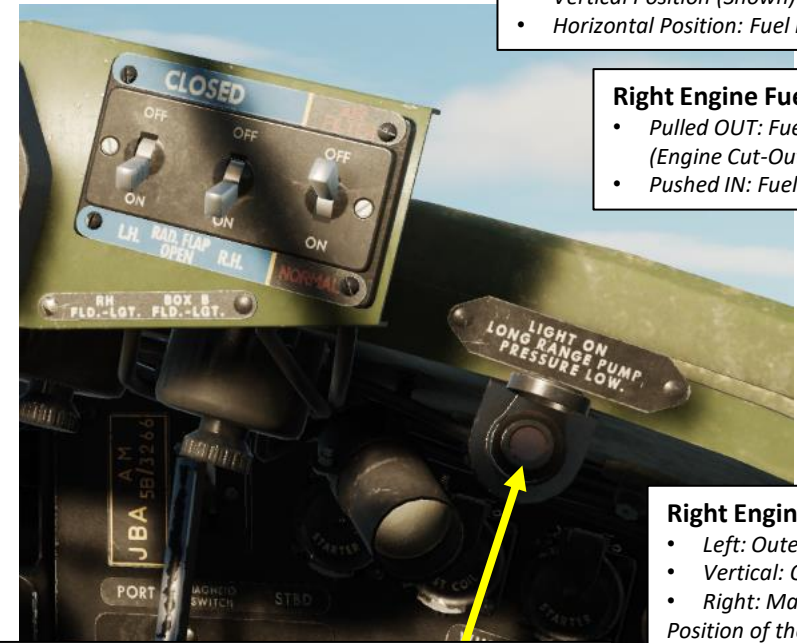

Immersed Fuel Pump Warning Light
• Light ON = Long Range Fuel Tank Pump Pressure Is Low

Right Engine Fuel Cut-Out Handle
• Pulled OUT: Fuel Valve Closed (Engine Cut-Out)
• Pushed IN: Fuel Valve Open

Right Engine Fuel Cock Selector
• Left: Outer Wing Tanks
• Vertical: OFF
• Right: Main Supply
Position of the selector is indicated by the white end of the handle.

Left Engine Fuel Cut-Out Handle
• Pulled OUT: Fuel Valve Closed (Engine Cut-Out)
• Pushed IN: Fuel Valve Open

Fuel Transfer Valve Control Handle
• Vertical Position (Shown): Fuel Transfer Valve Close (OFF)
• Horizontal Position: Fuel Transfer Valve Open (ON). Fuel pumps transfer fuel from the underwing tanks to the outer wing tanks

Left Engine Fuel Cock Selector
• Right: Outer Wing Tanks
• Vertical: OFF
• Left: Main Supply
Position of the selector is indicated by the white end of the handle.

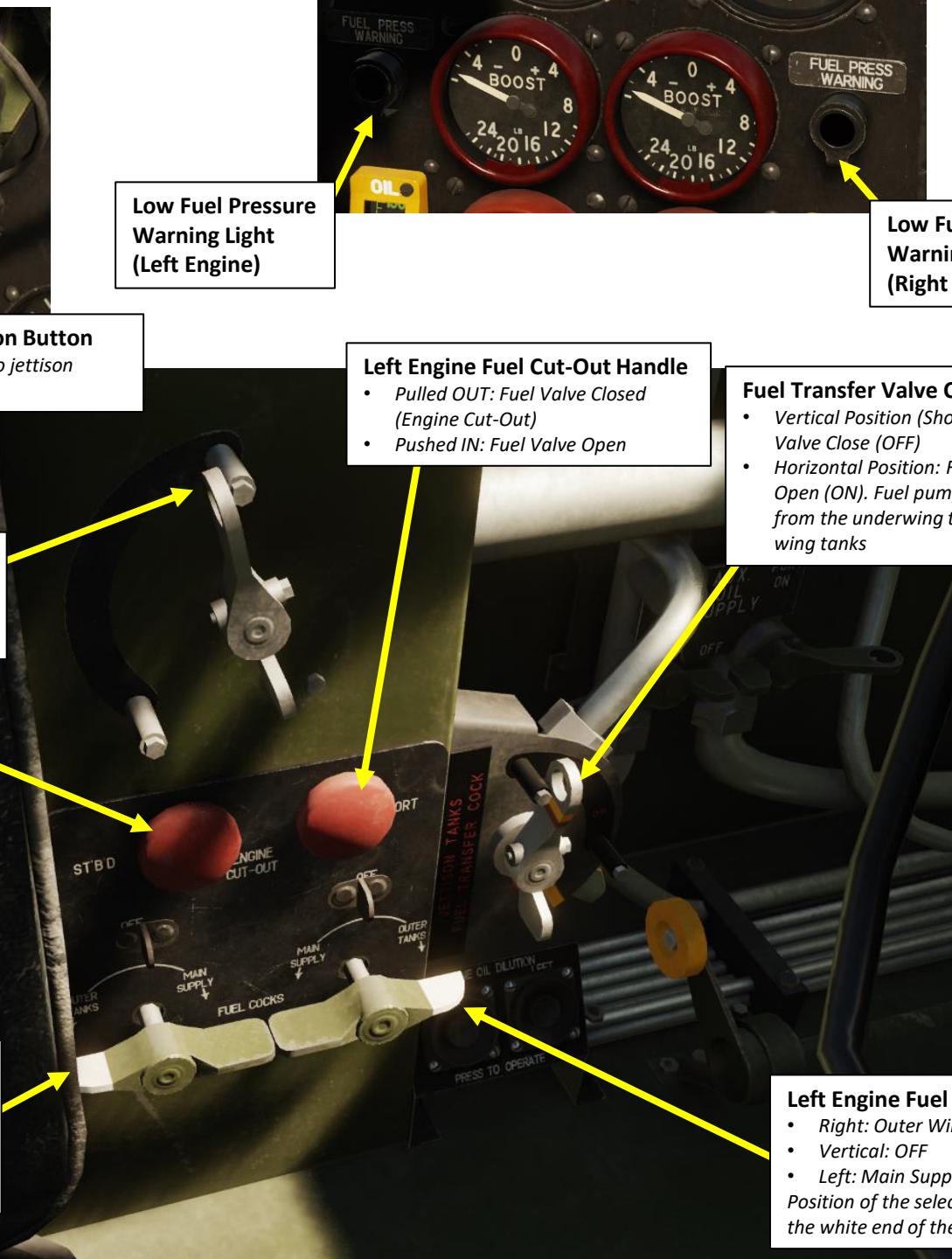



FUEL INDICATORS



Fuel Contents Gauges (Inner Wing Fuel Tanks) (Imperial Gallons)
 Portside/Left Tanks – Starboard/Right Tanks

- Beige Divisions: Fuel Quantity during flight
- Red Divisions: Fuel Quantity on ground (tail down)

Fuel Contents Gauge (Center Fuel Tanks) (Imperial Gallons)

- Beige Divisions: Fuel Quantity during flight
- Red Divisions: Fuel Quantity on ground (tail down)

Fuel Contents Gauges (Outer Wing Fuel Tanks) (Imperial Gallons)
 Portside/Left Tanks – Starboard/Right Tanks

- Beige Divisions: Fuel Quantity during flight
- Red Divisions: Fuel Quantity on ground (tail down)

Fuel Contents Gauge (Long-Range Tank, if fitted) (Imperial Gallons)

- Beige Divisions: Fuel Quantity during flight
- Red Divisions: Fuel Quantity on ground (tail down)



FUEL TANKS

The center tanks and the inner wing tanks supply both engines through a fuel collector box when the fuel cock selectors are set to MAIN SUPPLY.

Fuel Capacity (Internal Tanks)

- Total Inner Wing Fuel Tanks Capacity: 286 Imperial Gal
 - Total Outer Wing Fuel Tanks Capacity: 116 Imperial Gal
 - Total Center Fuel Tank Capacity: 50 Imperial Gal
- Total Capacity (Internal): 452 Imperial Gal**

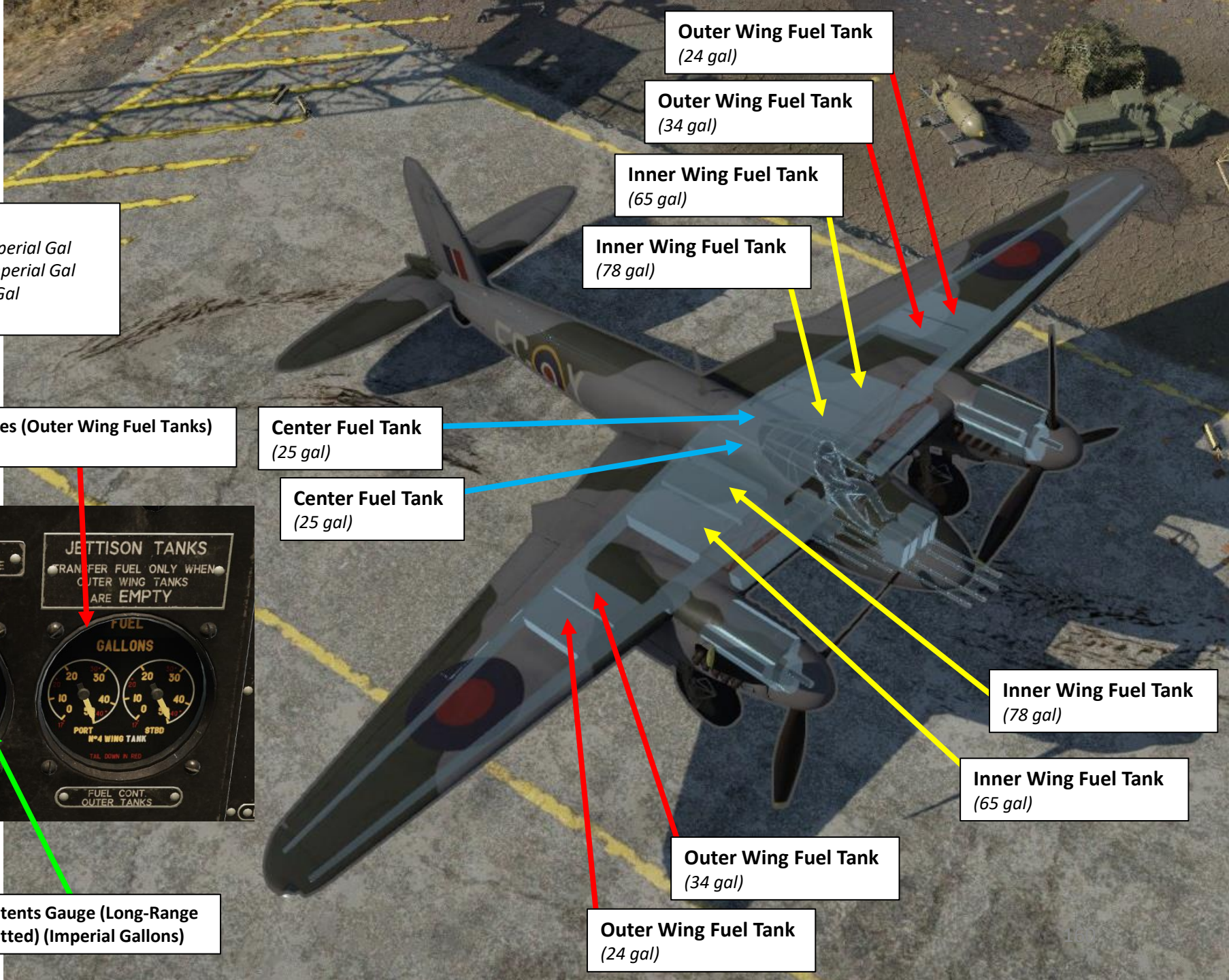

Outer Wing Fuel Tank
(24 gal)

Outer Wing Fuel Tank
(34 gal)

Inner Wing Fuel Tank
(65 gal)

Inner Wing Fuel Tank
(78 gal)

Center Fuel Tank
(25 gal)

Center Fuel Tank
(25 gal)

Inner Wing Fuel Tank
(78 gal)

Inner Wing Fuel Tank
(65 gal)

Outer Wing Fuel Tank
(34 gal)

Outer Wing Fuel Tank
(24 gal)

Fuel Contents Gauges (Outer Wing Fuel Tanks)
(Imperial Gallons)

Fuel Contents Gauge (Center Fuel Tanks)
(Imperial Gallons)

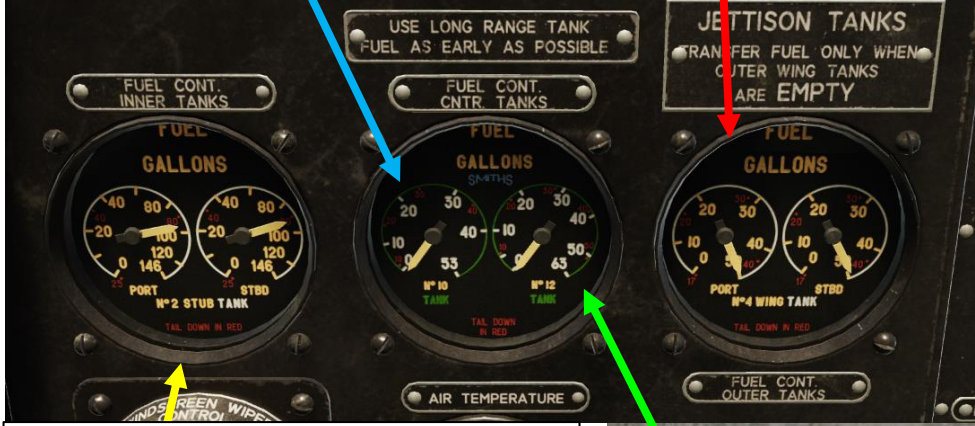

Fuel Contents Gauges (Inner Wing Fuel Tanks)
(Imperial Gallons)

Fuel Contents Gauge (Long-Range Tank if fitted)
(Imperial Gallons)



FUEL TANKS

Fuel Capacity (External Tanks)

- Two wooden external drop tanks can be installed under the wings with a capacity of either 50 Imperial Gal each, or 100 Imperial Gal each.

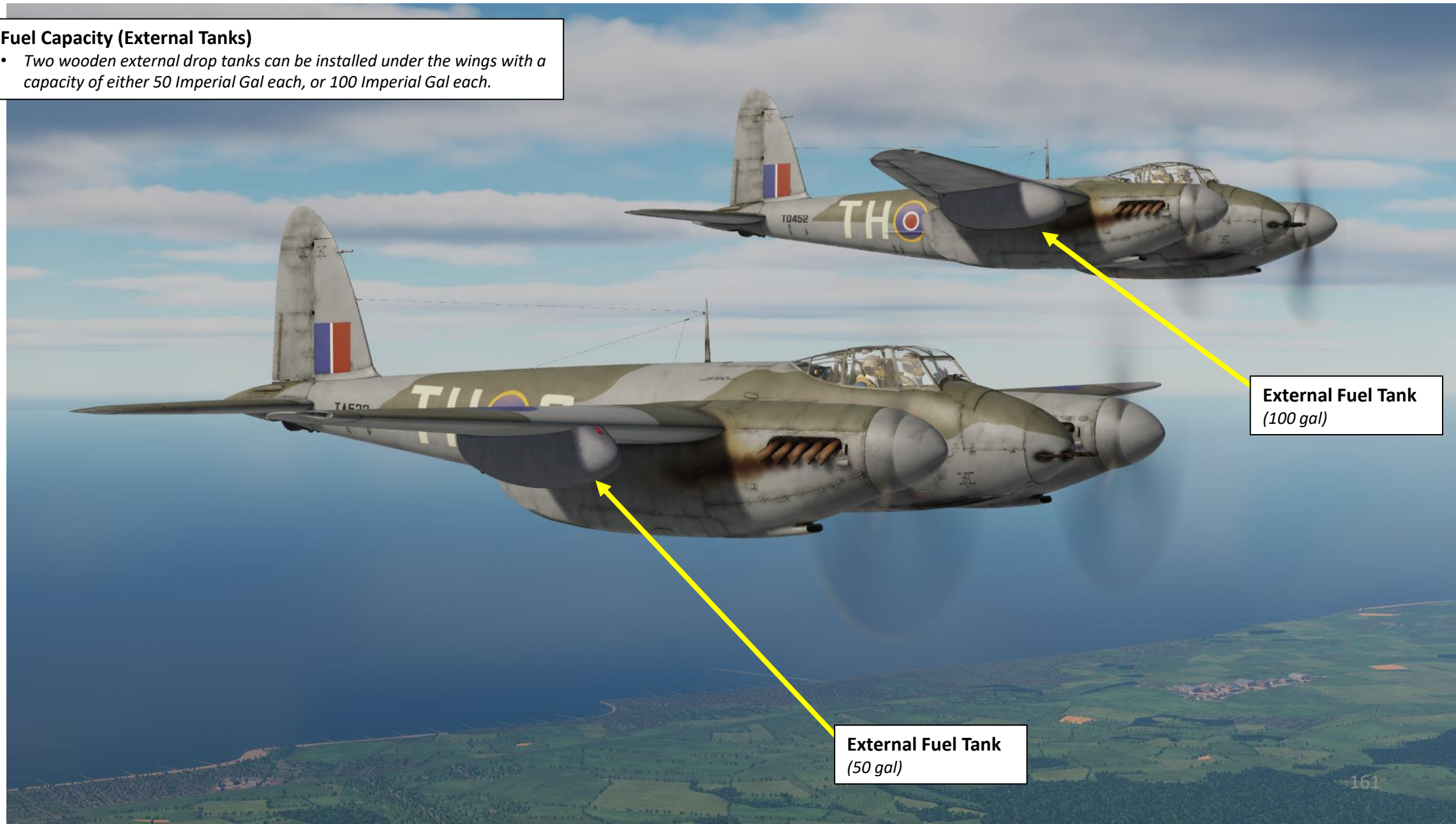

External Fuel Tank
(100 gal)

External Fuel Tank
(50 gal)



FUEL TANKS

Fuel Capacity (Long-Range Fuselage Tank)

- A long-range tank with a capacity of 63 Imperial Gal can be installed in the 20 mm cannon bay aft of the machineguns .
- **Note: The long-range tank is not simulated in DCS yet.**



Extra long-range fuel tanks in the bomb bay of De Havilland Mosquito TJ138, at the Royal Air Force Museum of London

• Photograph by Les Chatfield

Source: <https://www.flickr.com/photos/elsie/4607704928>



FUEL MANAGEMENT BASICS

The Mosquito FB Mk VI variant available in DCS uses 100-octane fuel, which is supplied internally by four outer wing tanks, four inner wing tanks, and two center tanks. Fuel management is mainly done by the Navigator since he is close to the fuel gauges and has an easier access to the fuel cock selectors than the pilot. Here are some general rules to follow:

1. Engine Fuel Cut-Out Handles should be IN at all times when engines are running. Pulling them closes the fuel valves and shuts down the engines.
2. Fuel Crossfeed between left and right engines is not possible; the fuel tanks on the right side can only supply the right engine, and vice-versa.
3. The Fuel Mixture Control Lever is only accessible from the pilot seat and can be used to lean out the mixture, reducing fuel consumption during cruise flight. When taking off, landing, climbing or dogfighting, it is better to leave the mixture to rich to maximize available power.
4. The Fuel Cock Selectors control which fuel tanks the engines feed from:
 - a) Select Outer Tanks during Engine Start.
 - b) Select Main Tanks (Inner + Center) during Engine Warm-Up.
 - c) Select the Fullest Tanks (Main or Outer) during taxi, takeoff and landing.
 - d) Select Outer Tanks when flying at medium altitudes (between 1000 and 15000 ft). The reason for this is that the Outer Tanks are the ones you want to empty first since their capacity is small, the outer tank fuel gauges becomes increasingly inaccurate as the fuel level decreases, and you do not want your engines to cut-out when flying 50 ft over the ground due to an erroneous fuel reading. The Outer Tanks are also not recommended to be used at high altitude (above 15000 ft) since these tanks are not pressurized without external drop tanks, which may cause engine cut-out due to fuel vaporization.
 - e) Select Main Tanks (Inner + Center) when flying at either low (below 1000 ft) or high altitudes (above 15000 ft).
 - f) Use of External Drop Tanks or the Long-Range Fuselage Tank is explained later in this section.
 - g) Fuel tanks should be consumed in this order of priority:
 - I. External Drop Tanks (provided the outer tanks have been partially emptied first)
 - II. Outer Tanks
 - III. Long-Range Fuselage Tank (If Installed)
 - IV. Main Supply (Inner + Center Tanks)

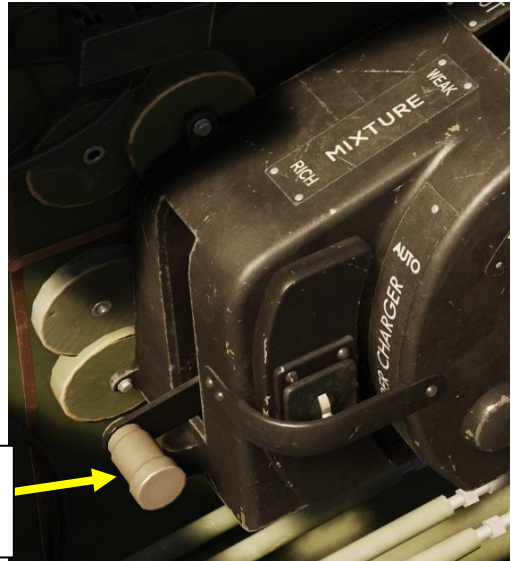

Fuel Mixture Control Lever

- *DOWN: Rich Mixture.*
- *UP: Weak Mixture*

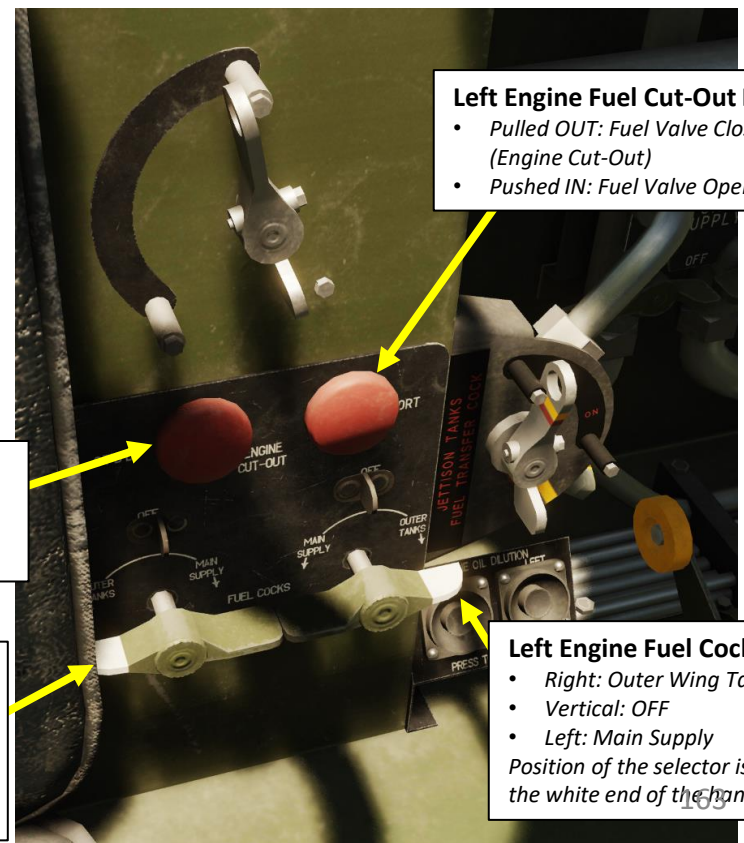

Left Engine Fuel Cut-Out Handle

- *Pulled OUT: Fuel Valve Closed (Engine Cut-Out)*
- *Pushed IN: Fuel Valve Open*

Right Engine Fuel Cut-Out Handle

- *Pulled OUT: Fuel Valve Closed (Engine Cut-Out)*
- *Pushed IN: Fuel Valve Open*

Right Engine Fuel Cock Selector

- *Left: Outer Wing Tanks*
- *Vertical: OFF*
- *Right: Main Supply*

Position of the selector is indicated by the white end of the handle.

Left Engine Fuel Cock Selector

- *Right: Outer Wing Tanks*
- *Vertical: OFF*
- *Left: Main Supply*

Position of the selector is indicated by the white end of the handle.

FUEL MANAGEMENT

FUEL TANK PRESSURIZATION

In order to prevent fuel boiling at high altitudes in warm weather conditions, the fuel system is equipped with a fuel tank pressurizer system. An aneroid valve feeds air, pressurized by a vacuum pump, into the fuel tanks. Pressurizing, however, impairs the self-sealing of the tanks, which can be problematic in case of a fuel leak.

To pressurize the permanent tanks of the **MAIN SUPPLY** (Inner and Center Fuel Tanks), set the **Fuel Tank Pressurization (Fuel Venting Cock) Control Handle to the Vertical Position (ON)**. Pressurizing is automatically regulated; the aneroid valve controls pressure from the starboard vacuum pump and progressively increases admitted air flow as increases. The valve stays shut at low altitudes.

The **Outer Tanks**, on the other hand, are only pressurized when the two following conditions are met:

- The Fuel Tank Pressurization (Fuel Venting Cock) Control Handle is
- Transfer of fuel is taking place from the wing drop tanks (Fuel Selector to Outer Tanks + Fuel Transfer Valve Control Handle OPEN).

Otherwise, when external drop tanks are not used, the Outer Tanks are NOT pressurized... even with the Fuel Venting Cock ON. In that case, vaporization within the outer tanks may cause engine cut-out at high altitudes, particularly in tropical climates.

In summary, I would recommend that you set the Fuel Tank Pressurization (Fuel Venting Cock) Control Handle ON (Vertical) unless you have an emergency (like a fuel leak) that requires you to turn it off.

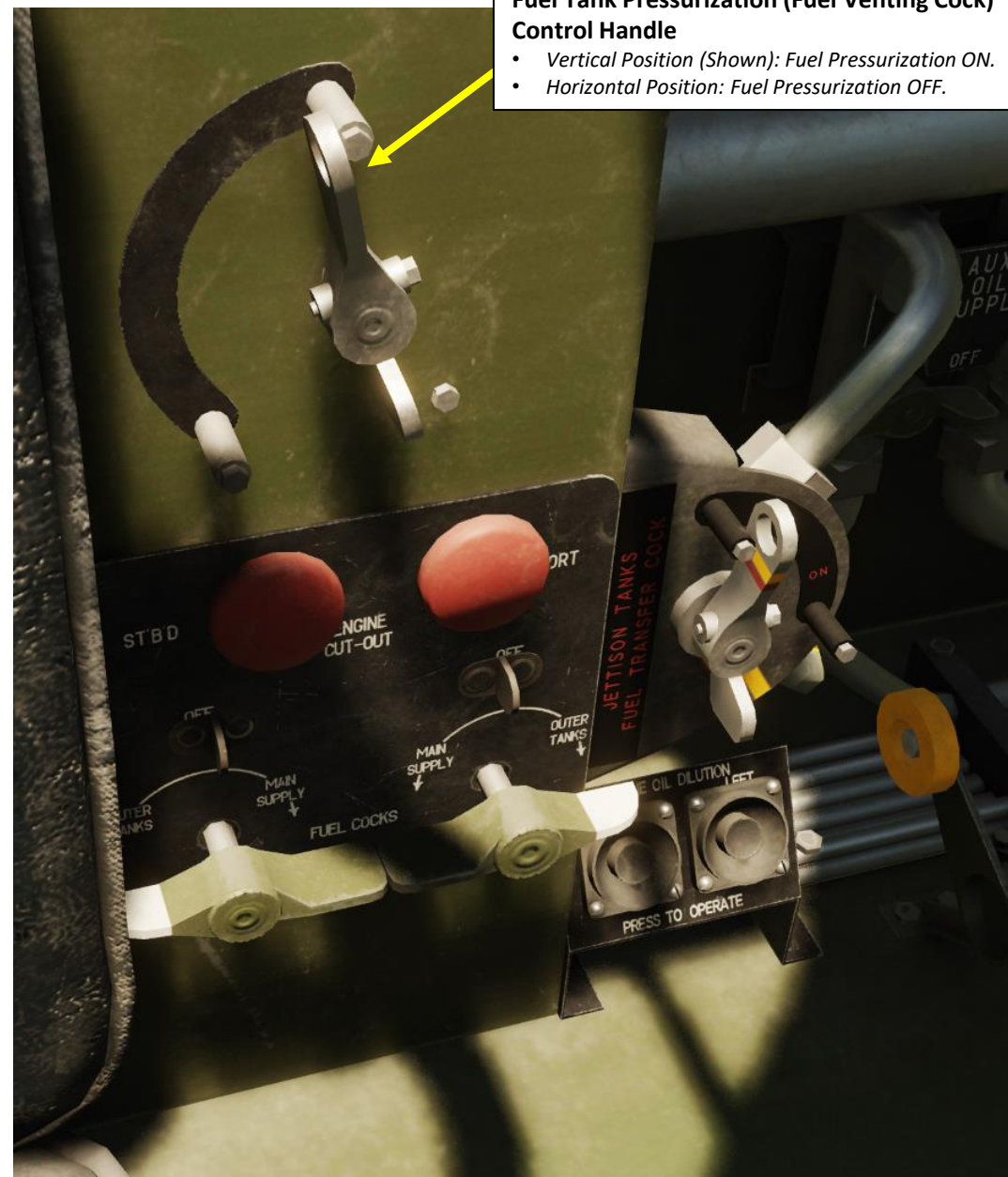

Fuel Tank Pressurization (Fuel Venting Cock) Control Handle

- Vertical Position (Shown): Fuel Pressurization ON.
- Horizontal Position: Fuel Pressurization OFF.



DH.98 MOSQUITO
FB MK VI

PART 7 – ENGINE & FUEL MANAGEMENT

FUEL MANAGEMENT EXTERNAL FUEL TANK OPERATION

1. Set Fuel Cock Selectors – OUTER TANKS.
2. Set Fuel Tank Pressurization (Fuel Venting Cock) Control Handle to the Vertical Position (ON).
 - *Note: Since the external drop tanks are not transferring fuel yet to the outer tanks, keep in mind that the outer tanks are not pressurized yet.*
3. Consume fuel from the outer tanks until fuel quantity in the outer tanks reaches 5 gal or less (nearly empty).
 - *Note: Failing to empty the outer tanks first will result in the fuel of the external tanks being vented to the atmosphere once the transfer valve opens up.*
4. Set the Fuel Transfer Valve Control Handle to the Horizontal Position (ON/OPEN). This will pressurize the outer tanks and transfer fuel from the external drop tanks to the outer tanks. The air pressure is supplied by the port vacuum pump, which is controlled by the transfer cock.
5. There is no fuel quantity indication for the external drop tanks.
6. The external drop tanks are empty once the Outer Tank Fuel Quantity starts decreasing again. In that case, it is time to switch to the Inner Tanks and jettison the drop tanks.

Interesting article on the restoration of a Mosquito's Wooden Drop Tank
<https://www.vam.ac.uk/blog/caring-for-our-collections/challenges-of-treating-a-mosquito-drop-tank>

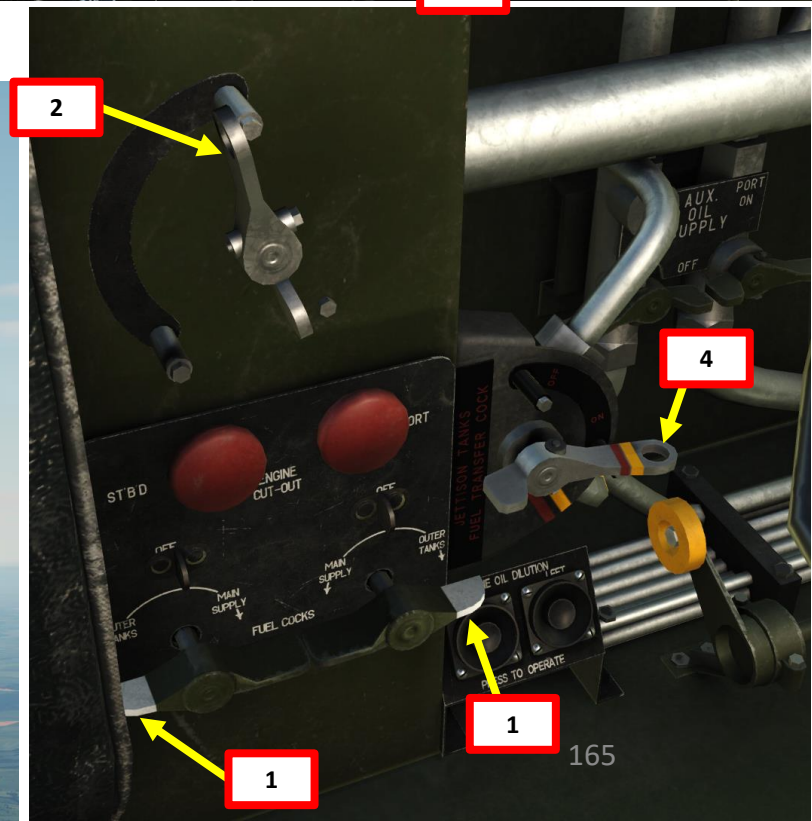

FUEL MANAGEMENT EXTERNAL FUEL TANK JETTISON

1. There is no fuel quantity indication for the external drop tanks. The external drop tanks are empty once the Outer Tank Fuel Quantity starts decreasing again.
2. Set Fuel Cock Selectors – MAIN SUPPLY
3. Set the Fuel Transfer Valve Control Handle to the Vertical Position (OFF/CLOSED).
4. Flip the safety cover of the External Wing Fuel Tank Jettison Button, then press the button to jettison drop tanks.

Note: Drop tanks should only be jettisoned in level flight without yaw, at speeds between 200 and 300 mph.

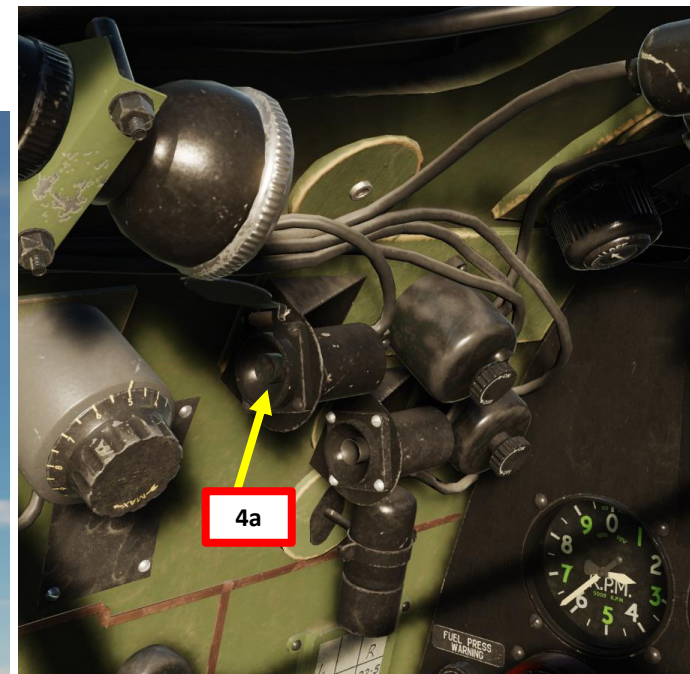
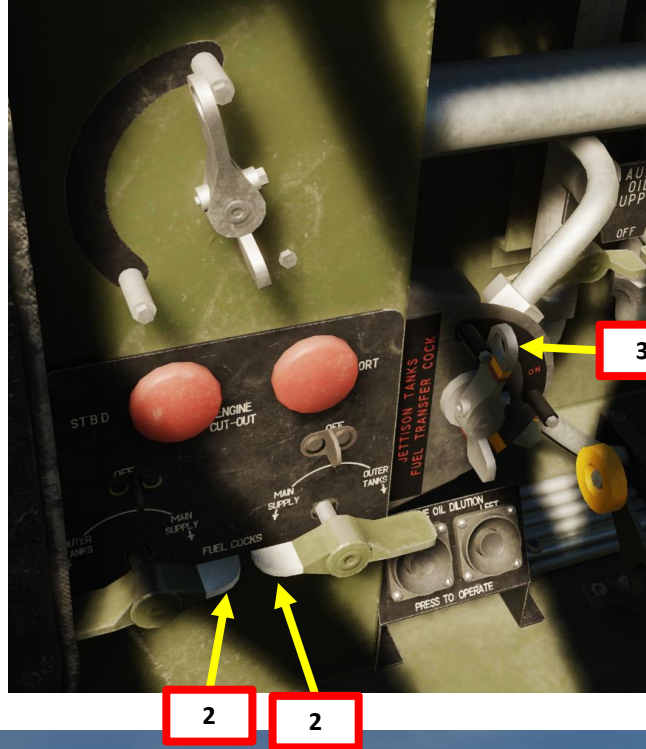

FUEL MANAGEMENT

LONG-RANGE FUEL TANK OPERATION

1. Confirm that the Long-Range Fuel Tank is installed on the aircraft by checking the Long-Range Tank Fuel Contents Gauge. The long-range tank has a capacity of 63 Imperial Gal and can be installed in the 20 mm cannon bay aft of the machineguns.
2. Set Fuel Cock Selectors – MAIN SUPPLY
3. Set Immersed Fuel Pump Switch – ON (DOWN)
4. When the Immersed Fuel Pump Warning Light illuminates, the Long-Range Tank is almost empty. Set the Immersed Fuel Pump Switch OFF (UP).
5. The engines will then take fuel from the inner and center fuel tanks (MAIN SUPPLY).

Note: the Long-Range Tank is not available in DCS yet.

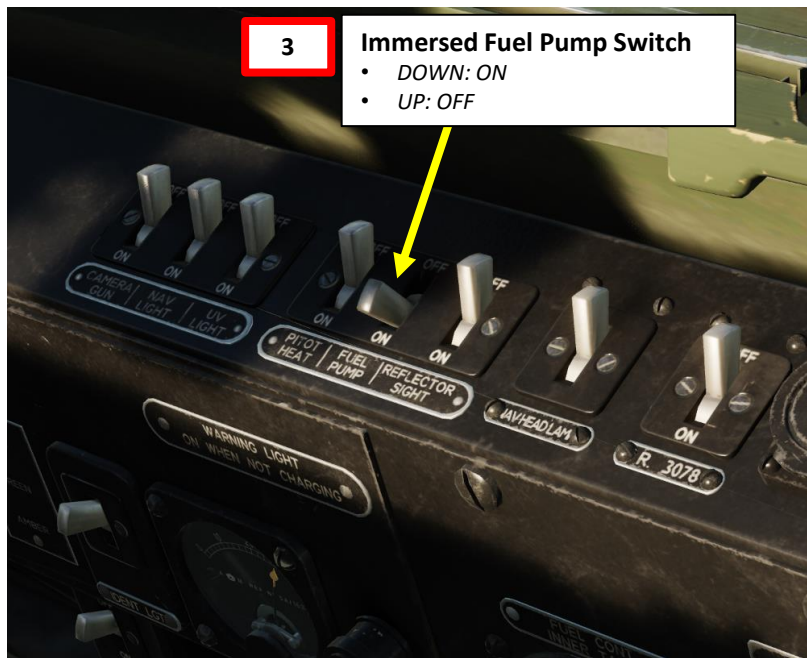

3 **Immersed Fuel Pump Switch**

- DOWN: ON
- UP: OFF



4 **Immersed Fuel Pump Warning Light**

- Light ON = Long Range Fuel Tank Pump Pressure Is Low

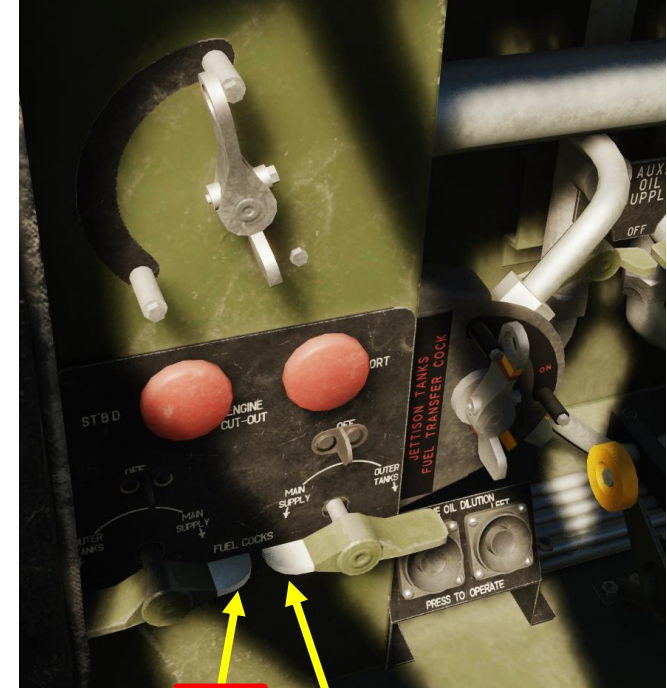

2 **2**



1

Fuel Contents Gauge (Long-Range Tank, if fitted) (Imperial Gallons)

- Beige Divisions: Fuel Quantity during flight
- Red Divisions: Fuel Quantity on ground (tail down)

AIRCRAFT AIRSPEED LIMITATIONS

Recommended Airspeeds (mph)	
Engine-Assisted Approach Speed (Both Engines Operating)	125
Glide Speed	140
Engine-Assisted Approach Speed with Flaps (Both Engines Operating)	135
Go-Around Climb Speed (Rejected Landing Climb Speed)	140
Maximum Rate-of-Climb (V _v)	175

Maximum Allowable Speeds (mph)				
	Without underwing stores or with 2 x 250 or 500 lbs bombs with standard wing bomb fairings	With 2 x 100 gal wing drop tanks	With underwing rockets or depth charges	With underwing stores
Sea Level to 10000 ft	425	380	405	350
10000 ft to 15000 ft	405	380	405	350
15000 ft to 20000 ft	370	370	370	350
20000 ft to 25000 ft	340	340	340	340
25000 ft to 30000 ft	300	300	300	300
30000 ft to 35000 ft	270	270	270	270
Bomb Doors Open				
			350	
Undercarriage Down				
			180	
Flaps not more than 25 deg Down				
			200	
Flaps Fully Down (45 deg)				
			150	



AIRCRAFT FLYING LIMITATIONS

- Recommended cruise speed when operating with both engines: 240 mph
- Recommended cruise speed when operating with a single engine: 180 mph
- Deliberate spinning is prohibited and an incipient spin should be checked by immediate recovery action.
- Although aerobatics are permitted at weights below 19100 lbs (without bomb load, underwing stores or wing drop tanks), they are not recommended owing to the possibility of damaging the special equipment.
- Controls are light and effective. Take care to avoid excessive accelerations in turns and recovery from dives. At high speeds, violent use of the rudder and large angles of yaw must be avoided.
- Maximum Weights
 - Takeoff and gentle manoeuvres: 20500 lbs
 - All forms of flying: 19000 lbs
 - Landing: 20500 lbs
- Firing of rockets is prohibited while carrying drop tanks and until at least one minute after they have been jettisoned.
- Wing drop tanks should only be jettisoned in level flight without yaw, at speeds between 200 and 300 mph.

ENGINE TORQUE EFFECT

The Mosquito does not have contra-rotating propellers, which means that the torque effect of each engine will add itself to the other's instead of cancelling it. This means that you will have to constantly compensate that torque effect with rudder input and rudder trim.

Both engines turn to the right (clockwise), which makes the aircraft want to swing towards the left. Wouldn't it have been easier to have two engines rotating in the opposite direction to help minimize the induced torque? Part of the reason behind this seemingly odd choice is that using two engines rotating in the same direction helped streamlining the production and reducing manufacturing costs, since creating a different engine variant required additional assembly lines.

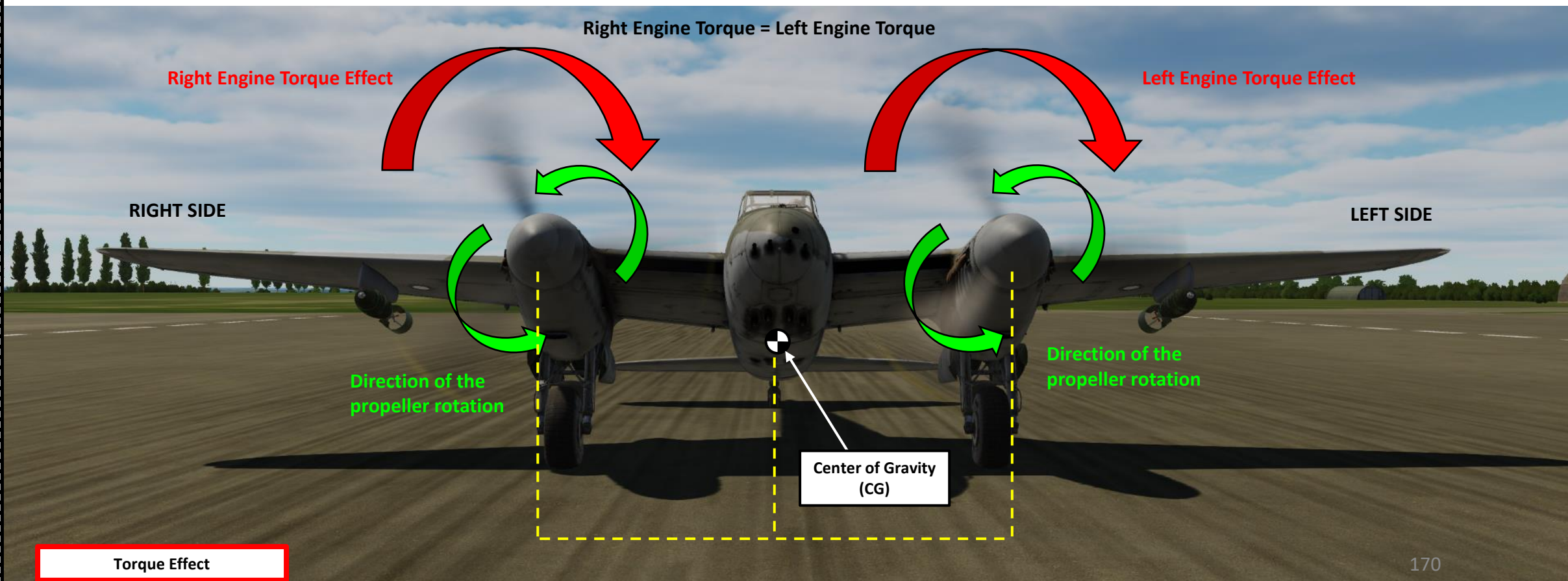



ASYMMETRIC PROPELLER LOADING EFFECT

Propeller asymmetric propeller loading is the result of dissimilar thrust from rotating propeller blades during certain flight conditions. Downward moving propeller blades have a greater local angle of attack than upward moving blades when the relative airflow striking the blades is not aligned with the thrust line. In conventional engines where the propeller rotates clockwise when viewed from the rear, asymmetric propeller loading results in the center of thrust shifting to the right of the propeller's centerline. As a result, the yaw moment of the right engine is greater than the corresponding one of the left engine (see figure below). The effects of asymmetric propeller loading are most pronounced when engines are operating at a high power setting and the airplane is flown at high angles of attack (low speeds). This means that losing the left engine has a bigger effect on the yaw moment than losing the right engine.

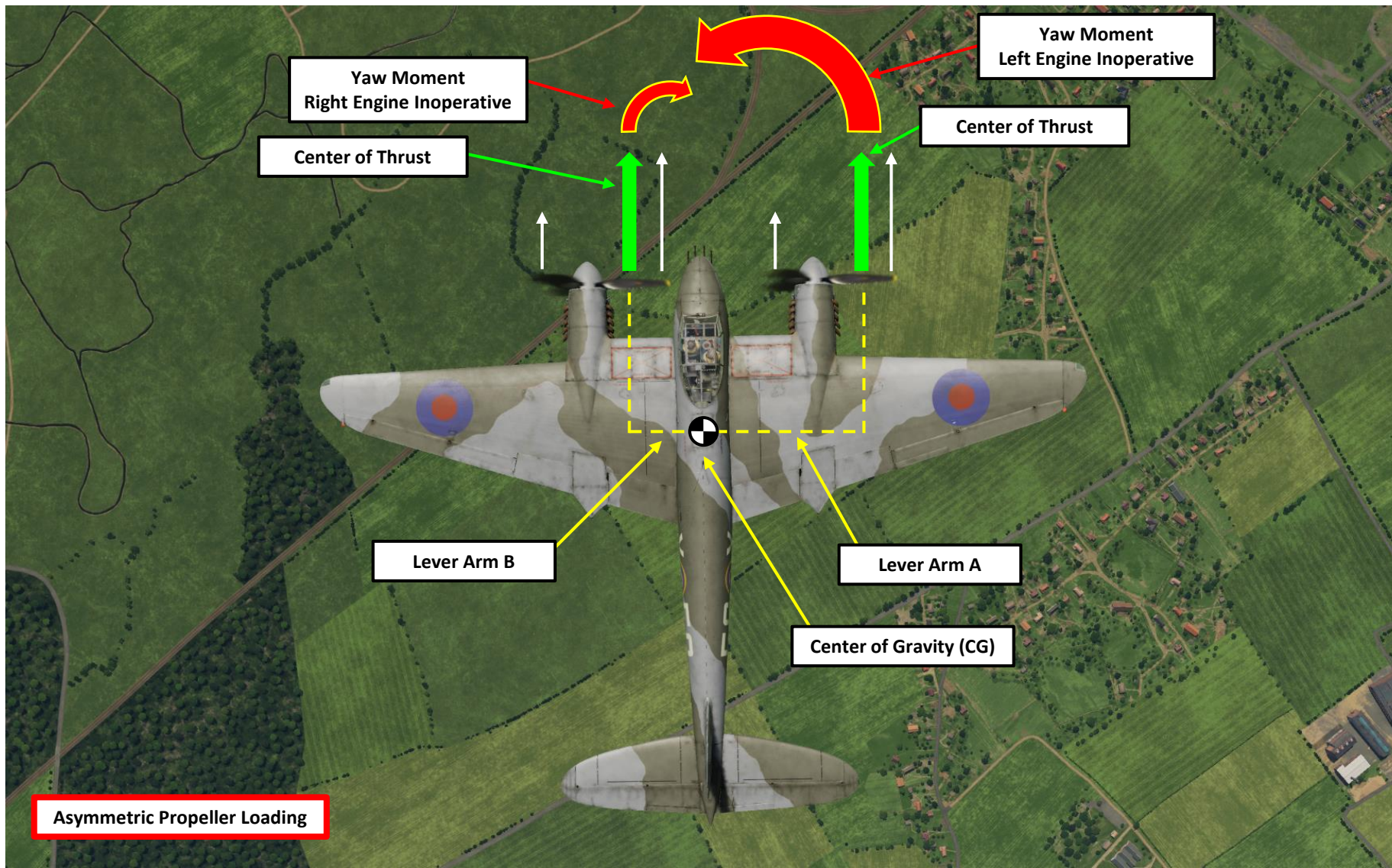



PROPELLER SLIPSTREAM EFFECT

Propeller slipstream refers to the accelerated airflow present in the wake of the propellers. As a spinning propeller produces thrust, it also imparts a spin and a lateral displacement to the airflow behind it - referred to as slipstream "swirl" or "spiraling".

If the propellers rotate clockwise (when viewed from the rear), the wake from the left propeller is displaced inboard with the result that the flow immerses the aft portion of the fuselage and tail in slipstream, as illustrated in figure below.

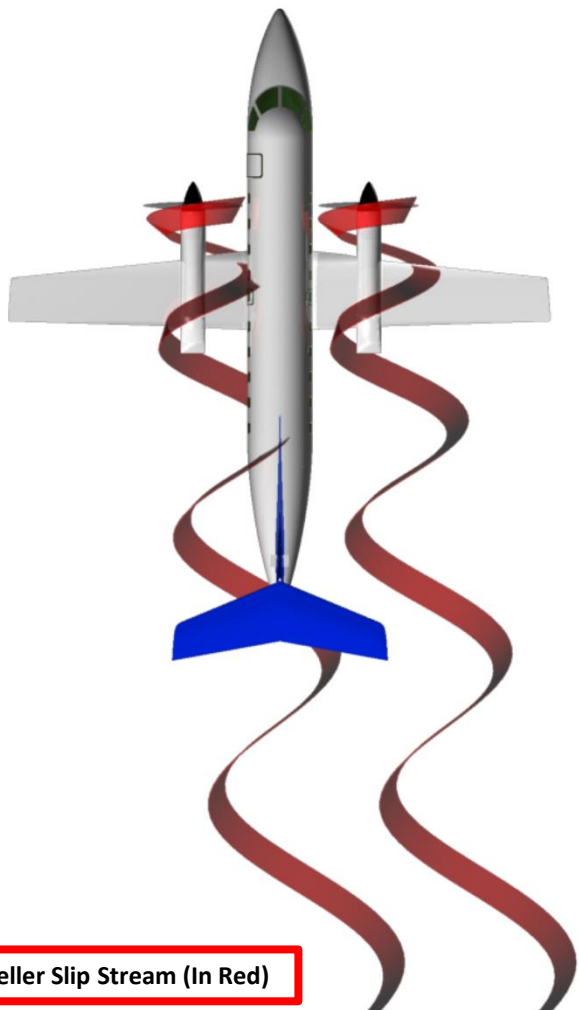

PROPELLER ASYMMETRIC LIFT DISTRIBUTION EFFECT

At high engine power, the air moving through the propellers is accelerated in order to produce the thrust. This also increases the local velocity of air flowing over the parts of the wing behind the propellers which generate more lift at a given airspeed.

The accelerated flow behind the propeller also causes a rolling phenomenon that is the result of asymmetric propeller loading. As you can see, when the center of thrust shifts right as the angle of attack is increased, the accelerated air behind the propeller shifts in a similar fashion.

Accelerated Slipstream – Roll Moment

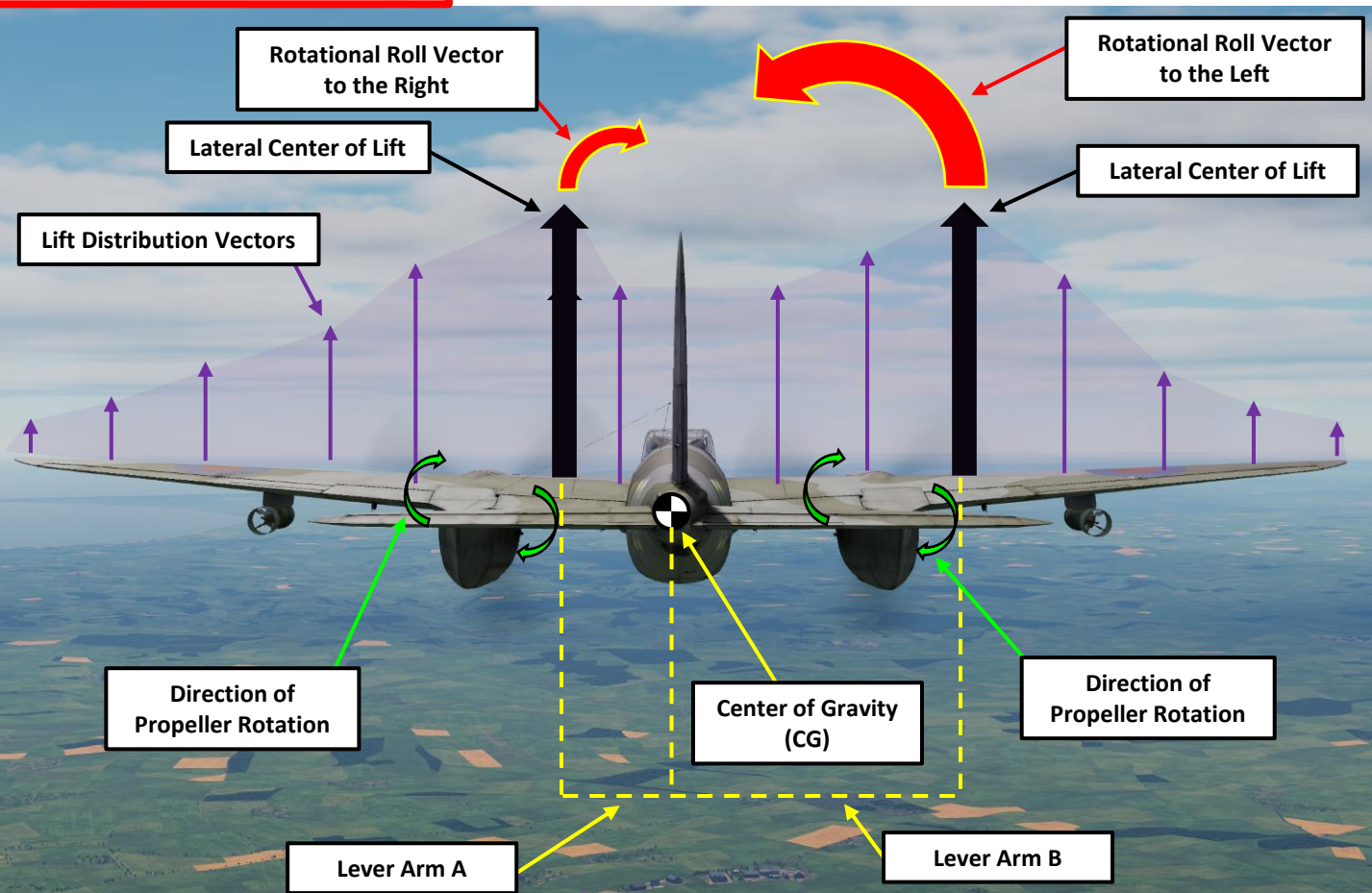

Accelerated Slipstream

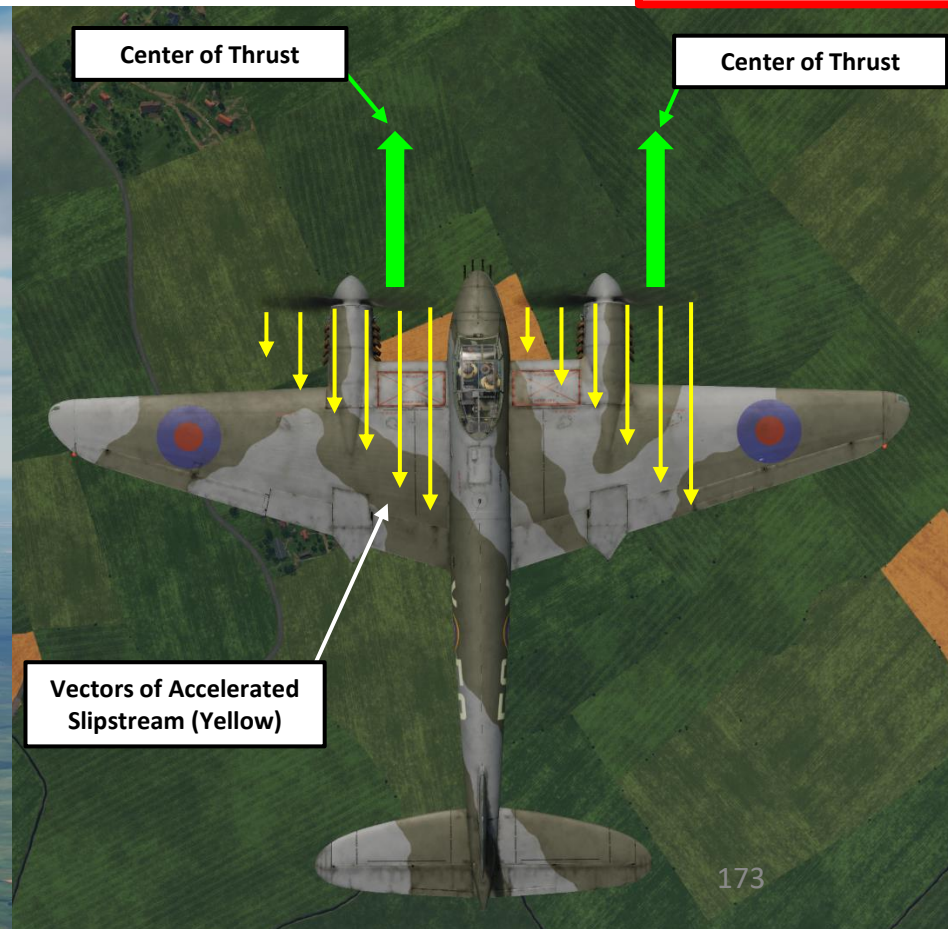

PART 10 – WEAPONS

**DH.98 MOSQUITO
FB MK VI**



ARMAMENT OVERVIEW

- 4 x Colt Browning .303 Machineguns (500 rounds per gun)
- 4 x Hispano Mk. II 20 mm Cannons (150 rounds per cannon)
- 4 x 250 lbs bombs (or 4 x 500 lbs bombs)
 - 2 in bomb bay
 - 2 under wings
- 8 x RP-3 Rocket Projectiles (3 in, with either 25 lbs or 60 lbs warheads)

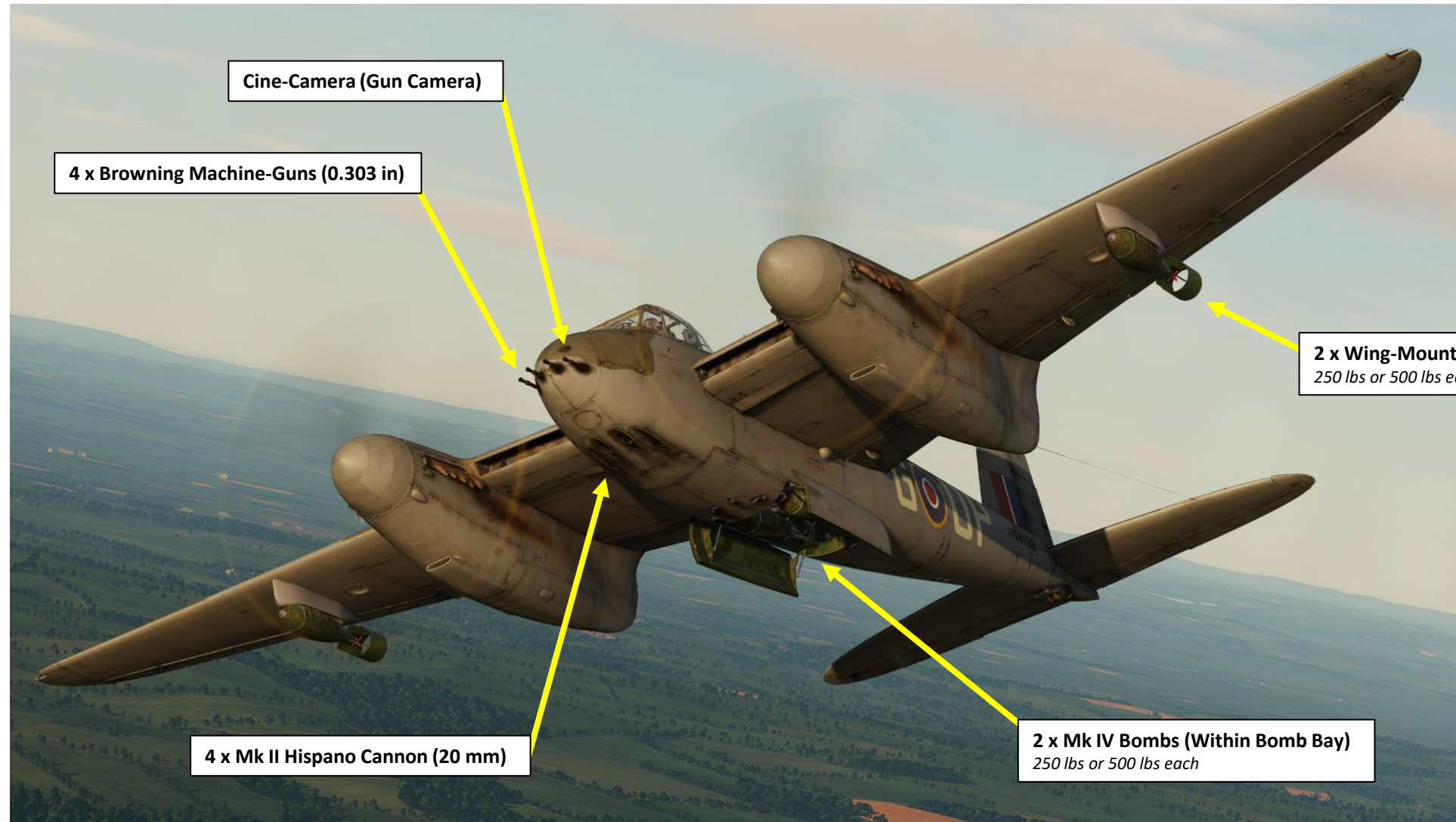

Cine-Camera (Gun Camera)

4 x Browning Machine-Guns (0.303 in)

2 x Wing-Mounted Mk IV Bombs
250 lbs or 500 lbs each

4 x Mk II Hispano Cannon (20 mm)

2 x Mk IV Bombs (Within Bomb Bay)
250 lbs or 500 lbs each



DH.98 MOSQUITO
FB MK VI

ARMAMENT OVERVIEW



8 x RP-3 Rockets (3 in)

PART 10 – WEAPONS

ARMAMENT MECHANISMS

The armament consists of four 20 mm. guns in the underside of the fuselage, and four .303 in guns and a camera gun in the nose. All guns are fired electro-pneumatically. The heat supply to the guns is controllable from the cockpit

The 20 mm guns are operated by a trigger, and the .303 in. guns by a push-switch on the control column. The gun master switch is located on the starboard instrument panel.

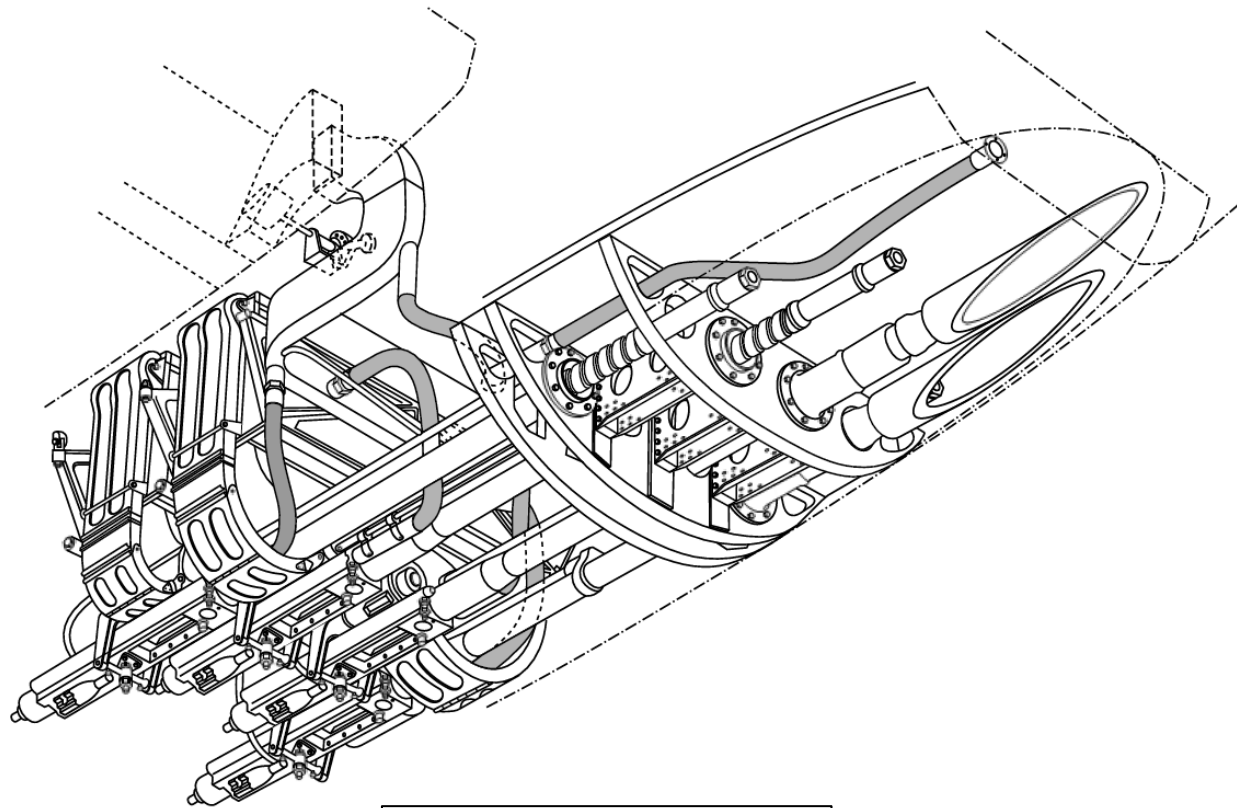

4 x Mk II Hispano Cannon (20 mm)

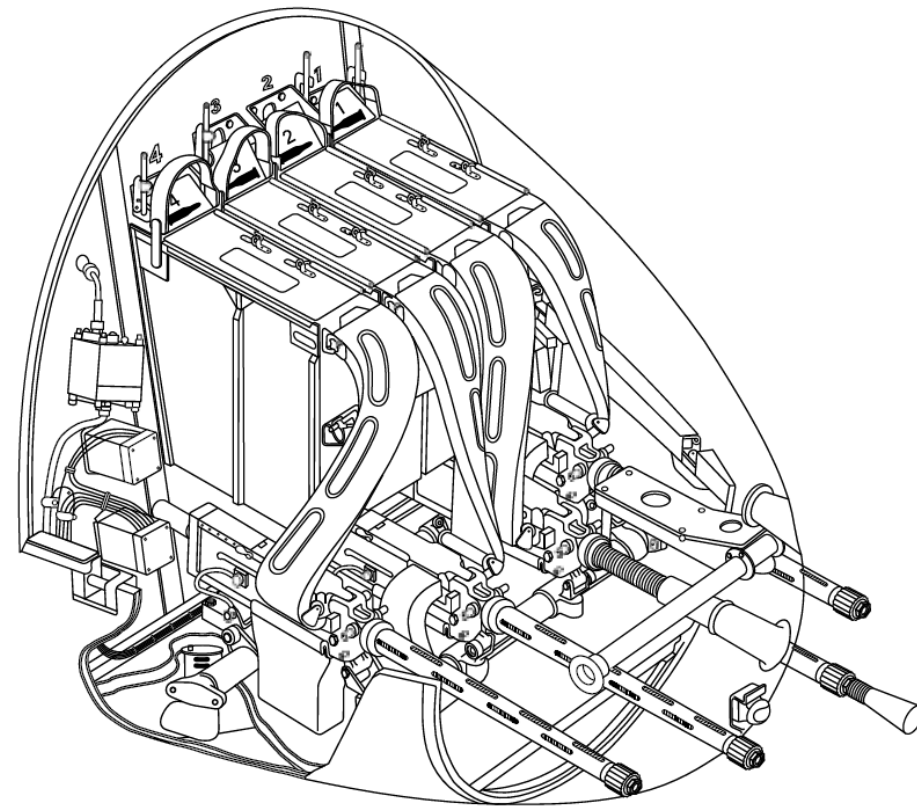

4 x Browning Machine-Guns (0.303 in)

ARMAMENT MECHANISMS

The pneumatic system operates the wheel brakes, the Browning guns, Hispano cannons, cine-camera, and flaps. Storage cylinders are kept charged by an engine-driven compressor and from them the supply is led to the various units in the system.

For the armament systems, pneumatic pressure controls the following components:

- Hispano cannons reload & firing mechanism
- Browning machineguns' firing, reloading & safety mechanism
- Camera gun
- Weapon fire buttons (on the control stick)

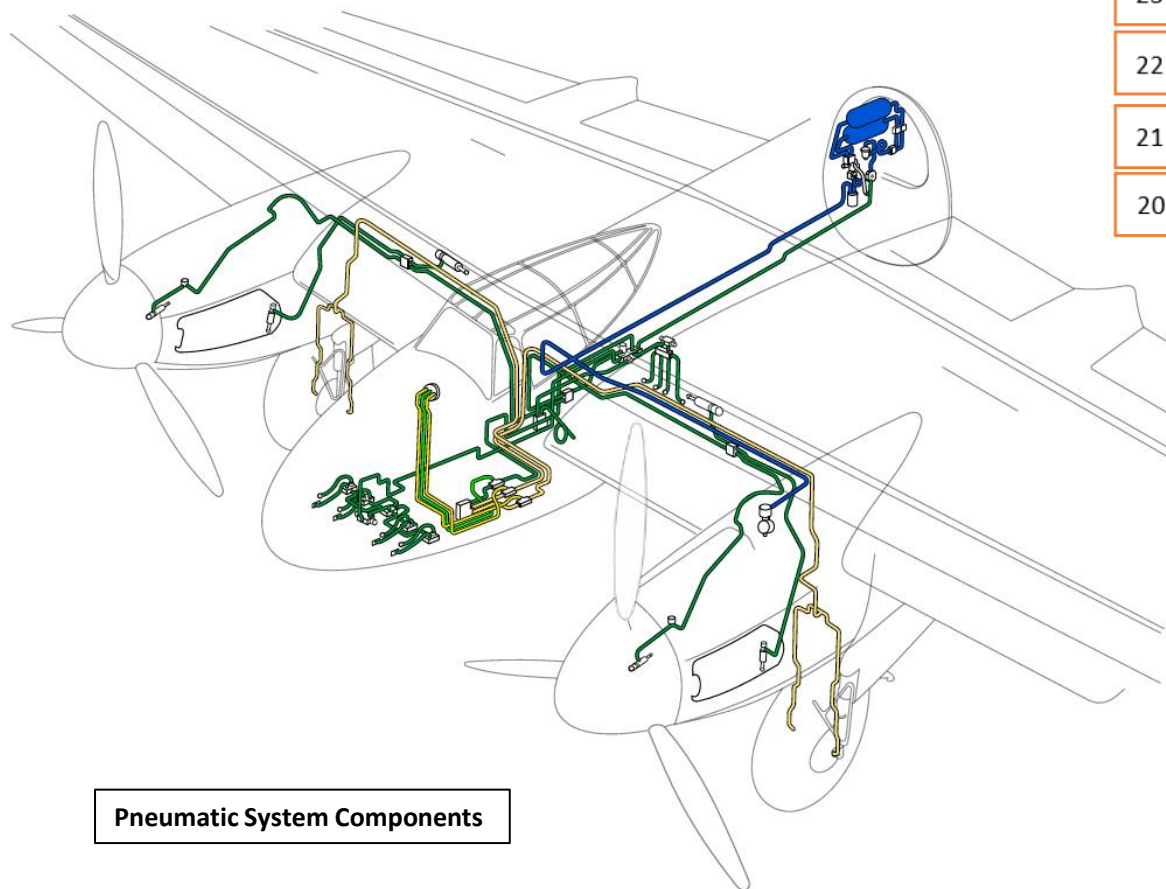

Pneumatic System Components

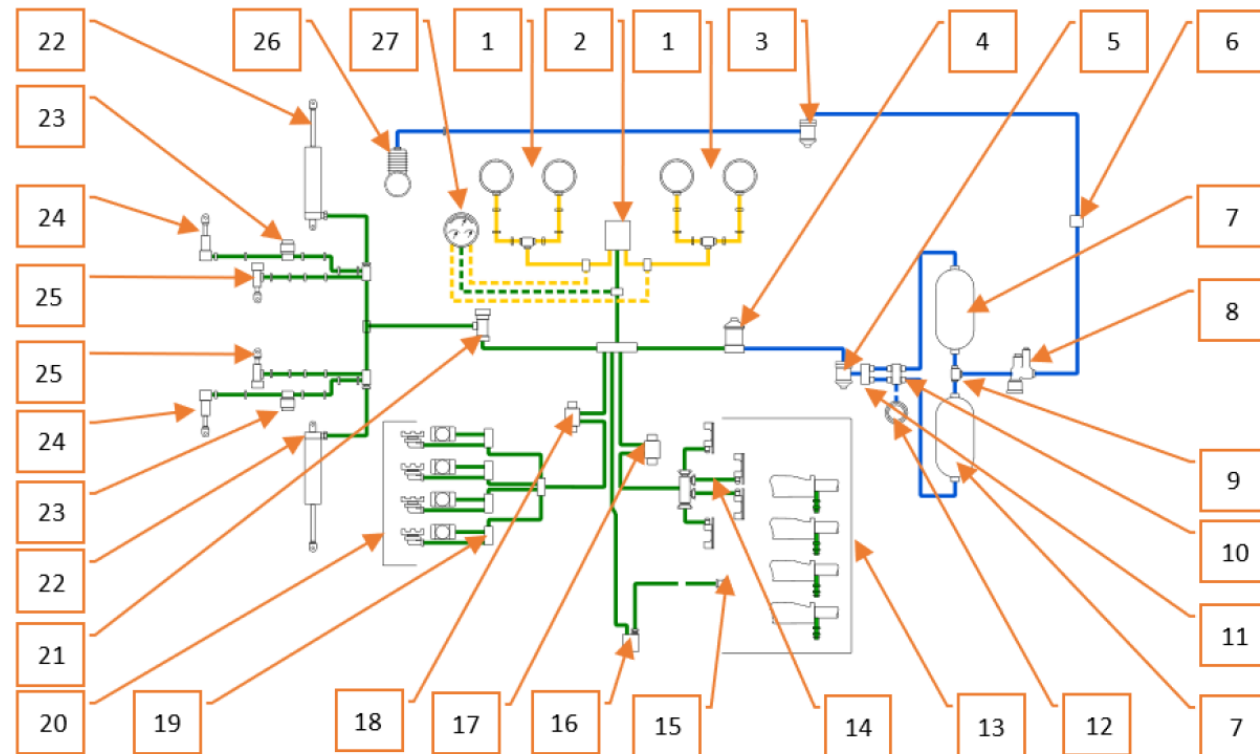

Pneumatic System

1. Wheel Brakes
2. Differential Unit
3. Oil Trap
4. Pressure Reducing Valve
5. Air Filter
6. Charging Connection
7. Dunlop air container
8. Pressure regulator Heywood type A.R.5
9. Non-Return Valves
10. Junction Block and Test Point
11. Non-Return Valves
12. Ground Check Pressure Valve
13. 20 mm Cannon Reload Mechanism
14. 20 mm Cannon Firing Control Mechanism

15. Dunlop Hose
16. Cocking Valve
17. Electro-Pneumatic Firing Valve
18. Electro-Pneumatic Firing Valve
19. Lag Valve
20. Browning .030 Block
21. Pressure Maintaining Valve
22. Pneumatic Cylinder
23. Magnetic Valve
24. Air Intake Control Ram
25. Supercharger Control Ram
26. Heywood Engine-Driven Compressor
27. Brake Pressure Gauge

BARR & STROUD MARK II GUNSIGHT - OVERVIEW

Your gunsight will show you where to shoot and when to shoot a target.

Gunsight Specifications:

1. Reticle ring diameter – angular values:
 - In degrees: 6° 44'
 - In thousandths (milliradians): 118
2. Reticle rings radius - angular values:
 - In degrees: 3° 22'
 - In thousandths (milliradians): 59
3. When shooting, this ring corresponds for allowance at an aspect of 2/4 and target speed of 200 mph (322 km/h).
4. At target aspect of 1/4, target speed should be 400 mph (644 km/h) .

	Range scale					
In hundreds of yards	1	2	3	4	5	6
Yards	100	200	300	400	500	600
Meters	91,4	182,8	274,2	365,6	457	548,4

	Base scale					
Feet	40	50	60	70	80	100
Meters	12,2	15,2	18,3	21,3	24,4	30,5

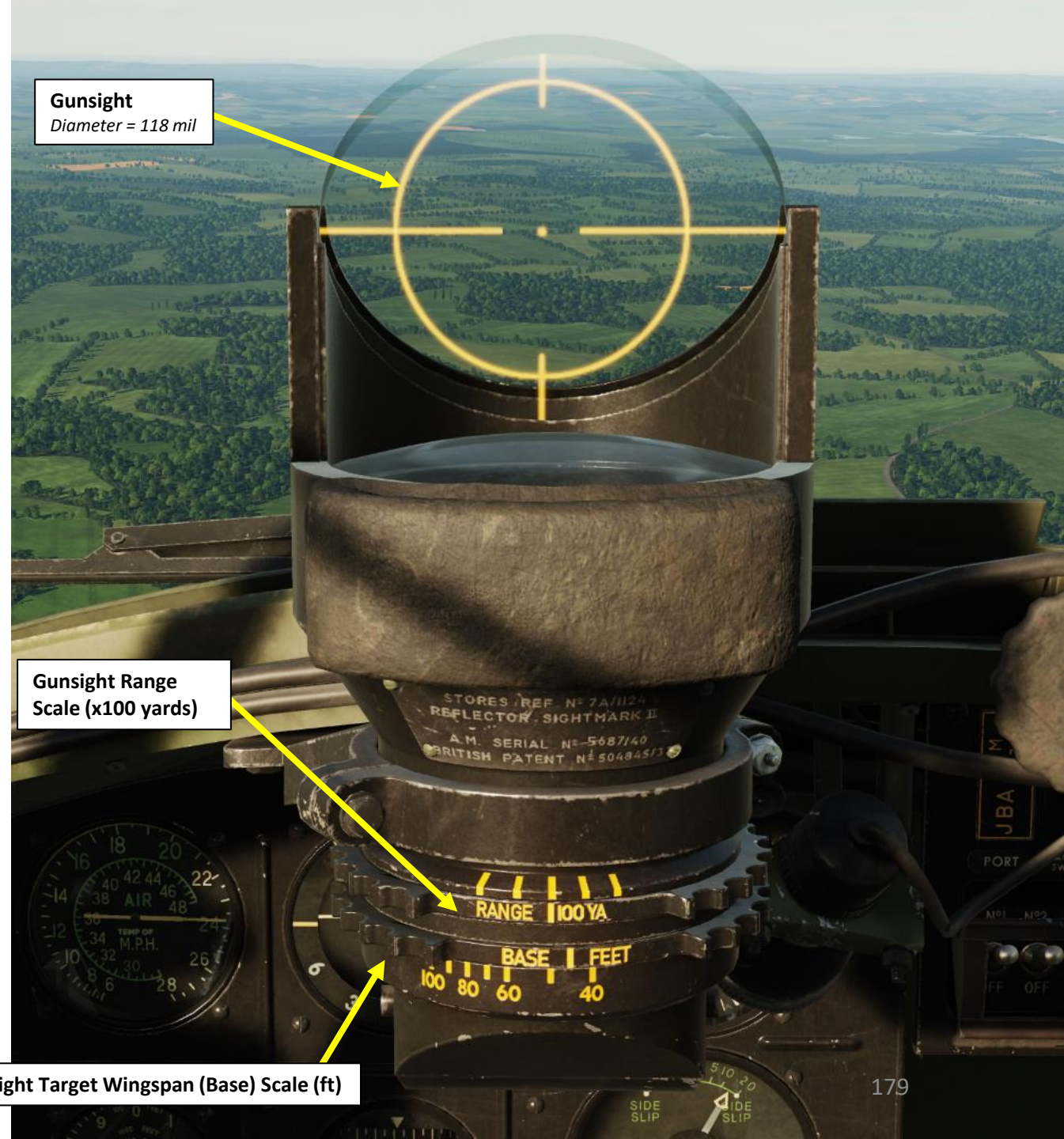

Gunsight
Diameter = 118 mil

Gunsight Range
Scale (x100 yards)

Gunsight Target Wingspan (Base) Scale (ft)

MARK II GUNSIGHT - TUTORIAL

To use the gunsight properly:

1. Set Reflector Gunsight Power switch to ON (DOWN)
2. Adjust Gunsight brightness as required
3. Set Gunsight Wingspan to 32 ft (typical FW190 and Bf.109 wingspan)
4. Set Gunsight Range to the distance you want to fire at. 300 yards is an adequate distance.
 - *Take note that in practice, it is usually the other way around. You spot a target, identify its type, then set the target wingspan and estimate its range by adjusting the Gunsight Range Control wheel.*

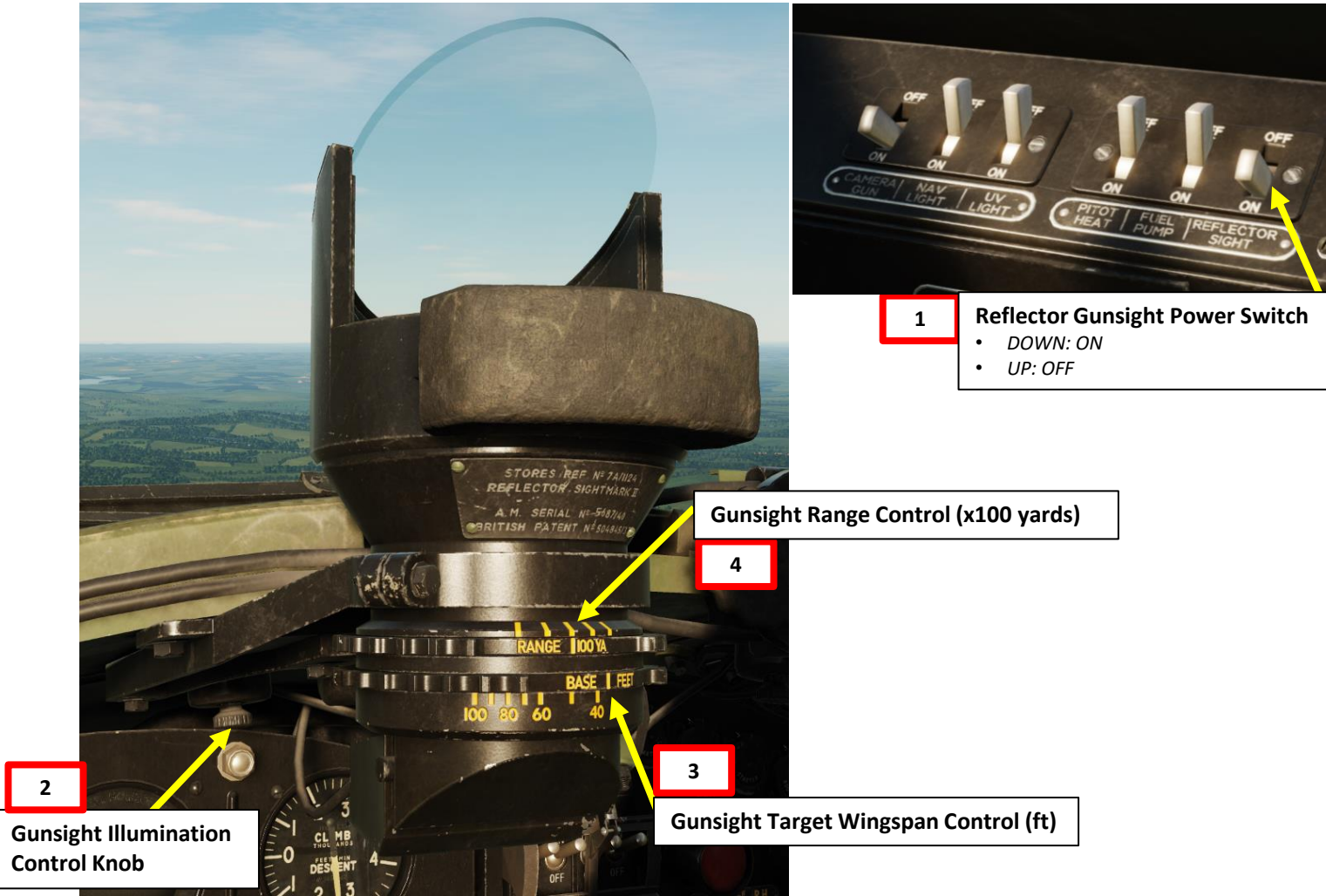

1 Reflector Gunsight Power Switch

- DOWN: ON
- UP: OFF

4 Gunsight Range Control (x100 yards)

2 Gunsight Illumination Control Knob

3 Gunsight Target Wingspan Control (ft)

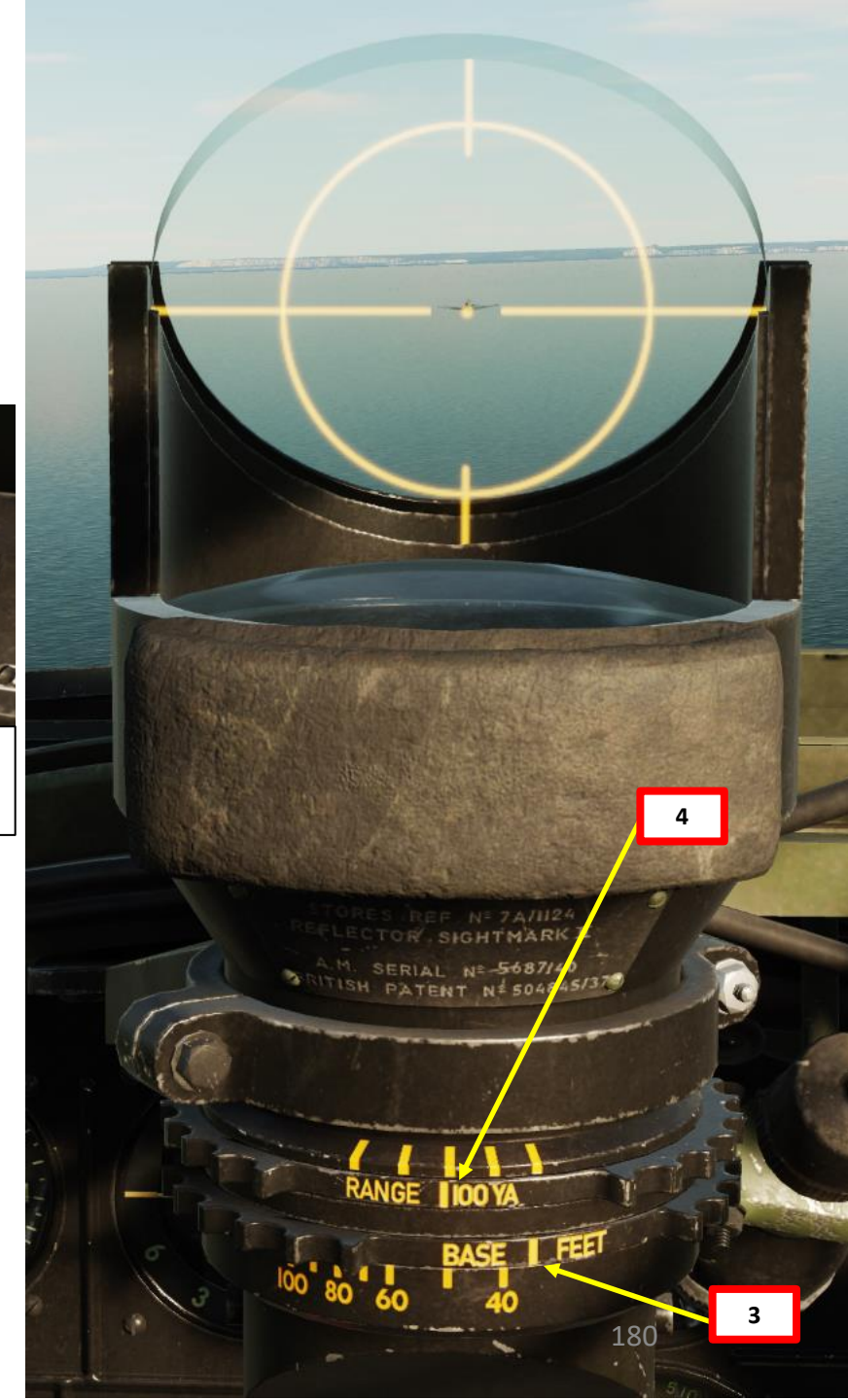

3

4

MARK II GUNSIGHT - TUTORIAL

5. The gunsight is aligned with the guns, which makes it difficult to see when sitting on the pilot seat (which isn't aligned with the gunsight). Lean on the gunsight and fit the target wings within your gunsight.
 - a) Leaning on the gunsight can be done in numerous ways (as per the Special Options tab), but my recommended method is the "Shift to aim when shoulder harness is released" option.
 - b) With this method, set a binding to "Shoulder Harness – Release/Lock". When you release the shoulder harness (lever UP), the pilot will automatically lean on the gunsight.
6. When the wing of the target fits in your gunsight, you are now in the range previously set.

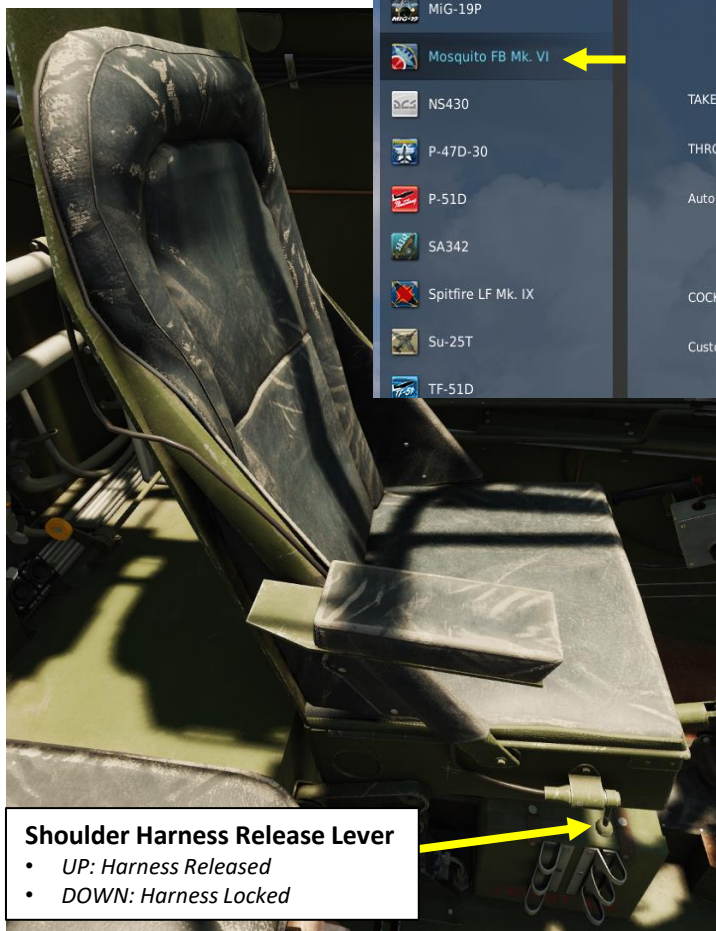
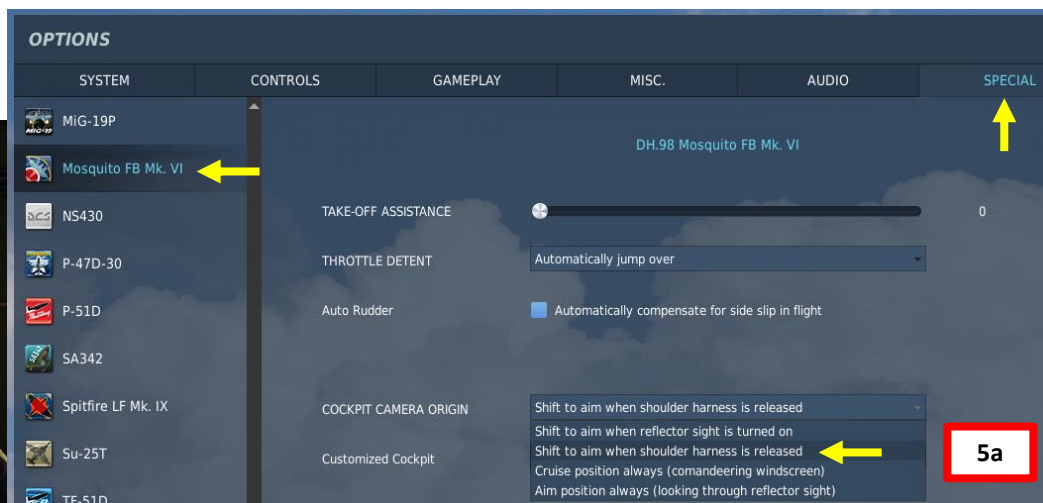
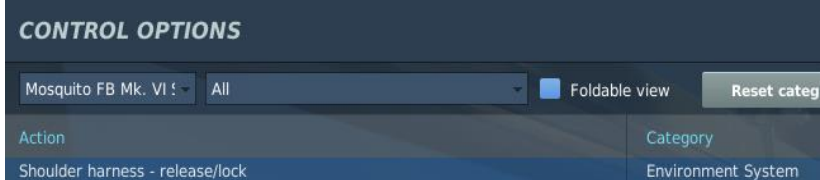

Shoulder Harness Release Lever

- UP: Harness Released
- DOWN: Harness Locked

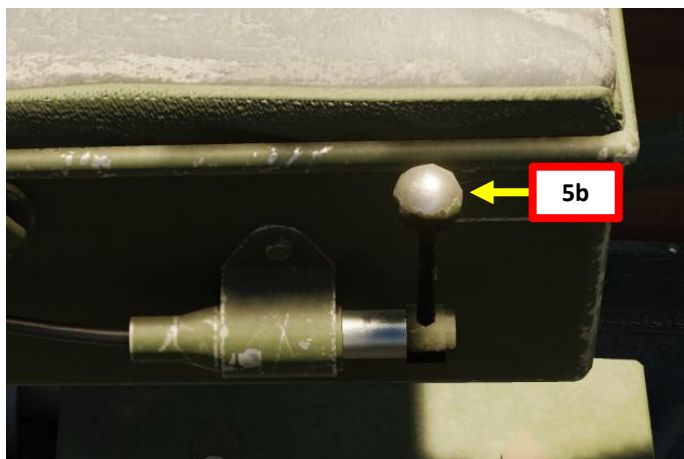

5b



Pilot Head Position – Cruise Position



Pilot Head Position – Aim Position

MARK II GUNSIGHT - RANGE ESTIMATION

Now... how do we know when the target is in range to fire? Typically, you choose a firing range/distance first (as an example, 300 yards / 275 meters), then place the fixed sight on the target and approach until it fits reference marks in “mils” (milliradians, which is an angle) for the desired firing distance.

As an example, let’s take a Bf.109, which has a wingspan (length) of about 32 ft (10 meters).

There is a rule in trigonometry that states that “in a right triangle, the tangent (tan) of an angle is the length of the opposite side divided by the length of the adjacent side”. For very small angles, simplifications can be made. I’ll spare you the math, but the bottom line is:

$$\frac{\theta}{2} = \arctan\left(\frac{L/2}{D}\right)$$

For small angles, $\arctan\left(\frac{L/2}{D}\right)$ can be approximated to $\frac{L/2}{D}$

Therefore: $\theta = \frac{L}{D}$

We know the reticle diameter represents an angle of 118 milliradians (118 thousandths of a radian, or 6° 44’ in degrees). From the equation above, we can determine what distance D_1 the target is from us when its wingspan (L_1) fits within the reticle diameter.

For a target with a length $L_1 = 10$ m that fits within the reticle angle θ_1 of 118 milliradians:

$$\theta_1 = 118 \text{ mil} = \frac{L_1}{D_1}$$

$$D_1 = \frac{L_1}{\theta_1} = \frac{10 \text{ m}}{0,118 \text{ rad}} = 85 \text{ meters}$$

For a target with a length $L_2 = 10$ m at a distance D_2 of 275 m (the range we actually want to fire at):

$$\theta_2 = \frac{L_2}{D_2} = \frac{10 \text{ m}}{275 \text{ m}} = 0.036 \text{ rad} \approx 35 \text{ mil (milliradians)}$$

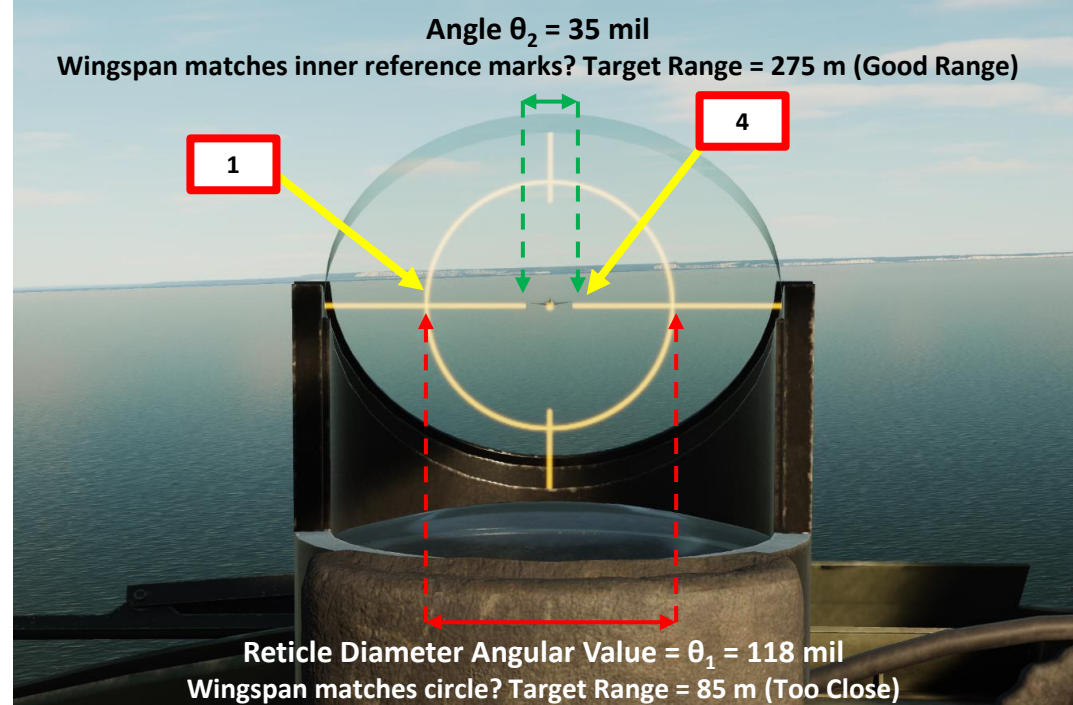
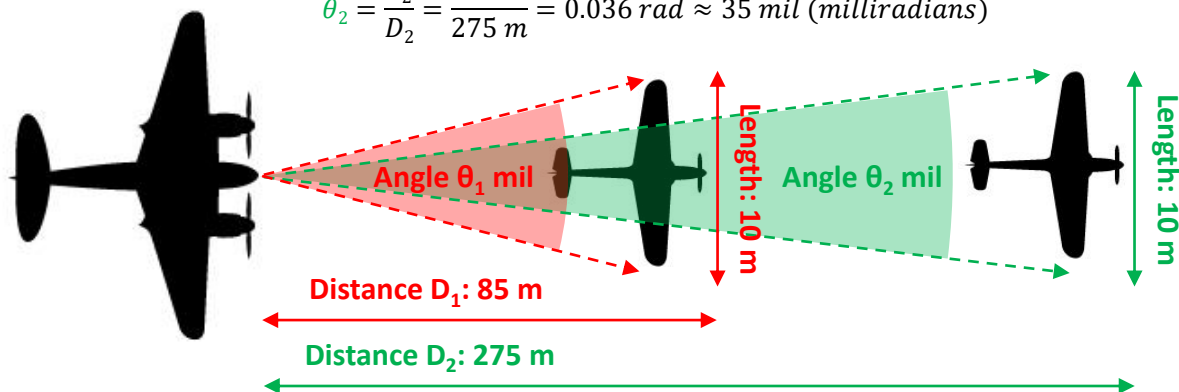

Now... how do we interpret the gunsight to estimate the range of a target?

1. We know the **reticle diameter** is 118 mil (118 thousandths of a radian, or 6° 44’ in degrees).
2. We calculated that when the wingspan of a target fits within the diameter of the reticle, we are at a range of approx. 85 meters, which is way too close.
3. Using the **RANGE** and **BASE** gunsight settings, we can set the **inner reference marks** of the gunsight to a distance of 300 yards / 275 m (optimal firing range) adjusted for a wingspan of 10 m (32 ft).
4. When target wings fit within the **reticle inner reference marks**, we know we are at the optimal firing range of 300 yards. You may fire.

HISPANO 20 MM CANNONS & BROWNING 0.303 IN MACHINEGUNS

1. Ammunition belt types are customizable via the mission editor.
2. Ensure pneumatic pressure is no less than 200 psi. Insufficient pneumatic pressure may prevent the machinegun and cannon firing mechanisms from firing properly.
3. Set Reflector Gunsight Power switch to ON (DOWN)
4. Set Cine-Camera (Gun Camera) Master Switch – ON (DOWN)
5. Adjust Gunsight brightness as required
6. Set Gunsight Wingspan to 32 ft (typical FW190 and Bf.109 wingspan)
7. Set Gunsight Range to the distance you want to fire at. 300 yards is an adequate distance.

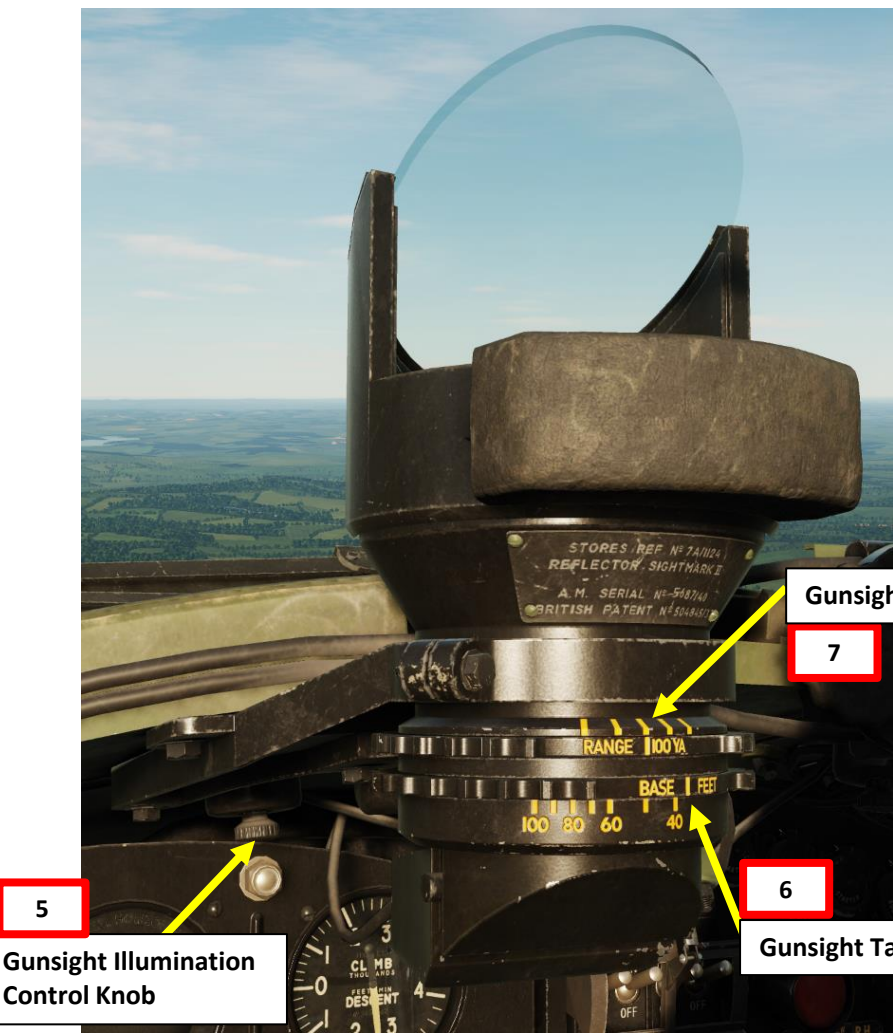

5

Gunsight Illumination Control Knob

7

Gunsight Range Control (x100 yards)

6

Gunsight Target Wingspan Control (ft)



3

Reflector Gunsight Power Switch

- DOWN: ON
- UP: OFF

Cine-Camera (Gun Camera) Master Switch

- DOWN: ON
- UP: OFF

4

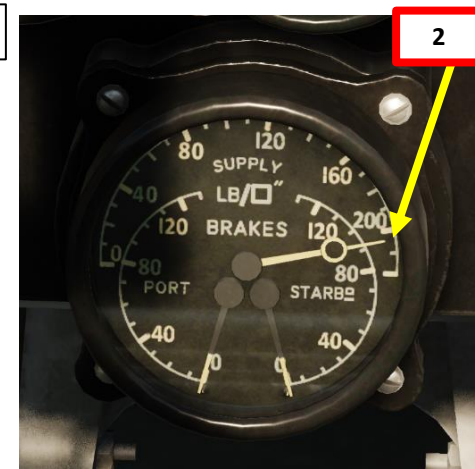

2

TYPE: Mosquito FB Mk. VI

SKILL: Player

PILOT: Aerial-1-1

TAIL #: UPGTA122

RADIO: [checked] FREQUENCY: 124 MHz AM

CALLSIGN: Enfield 1 1

HIDDEN ON MAP

HIDDEN ON PLANNER

HIDDEN ON MFD LATE ACTIVATION

CIVIL PLANE

INTERNAL FUEL: 67 %

FUEL WEIGHT: 2197 lbs

EMPTY: 14343 lbs

WEAPONS: 2471 lbs

MAX: 24251 TOTAL: 19013 lbs

78 %

CHAFF: 1

FLARE: 0

GUN: 100 %

AMMO TYPE: APIT AP/De Wilde (Tracer) - 20mm HEI/S, v

APIT AP/De Wilde (Tracer) - 20mm HEI/SAPI/APT

- BaIT Ball/De Wilde (Tracer) - 20mm HEI/SAPI/APT
- API AP/De Wilde (No Tracer) - 20mm HEI/SAPI
- Bal Ball/De Wilde (No Tracer) - 20mm HEI/SAPI
- CM - Combat Mix
- HE - Anti-Bomber
- AG - Ground Attack
- CS - No Tracers
- NO - Night Time Tracers
- TP - Target Practice

HISPANO 20 MM CANNONS & BROWNING 0.303 IN MACHINEGUNS

8. If required, set Gun Heating Lever ON (FWD).
9. The gunsight is aligned with the guns, which makes it difficult to see when sitting on the pilot seat (which isn't aligned with the gunsight). Lean on the gunsight and fit the target wings within your gunsight.
 - a) Leaning on the gunsight can be done in numerous ways (as per the Special Options tab), but my recommended method is the *"Shift to aim when shoulder harness is released"* option.
 - b) With this method, set a binding to *"Shoulder Harness – Release/Lock"*. When you release the shoulder harness (lever UP), the pilot will automatically lean on the gunsight.



Shoulder Harness Release Lever

- UP: Harness Released
- DOWN: Harness Locked



Gun Heating Lever

- FWD: ON
- AFT: OFF

8

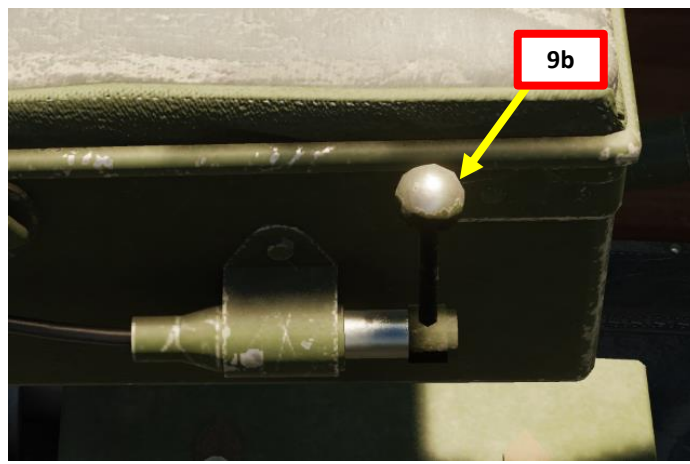

9b

HISPANO 20 MM CANNONS & BROWNING 0.303 IN MACHINEGUNS

10. Remove gun safety by flipping the Master Arm Safety Cover DOWN and setting the Gun Master Arm Switch ON (DOWN).
11. When the wing of the target fits in your gunsight, you are now in the range previously set.
12. Fire by pressing and holding the Cannon Firing Button (RALT+SPACE binding) and the Machinegun Firing Button (SPACE binding).



Cannon Firing Button
• RALT+SPACE

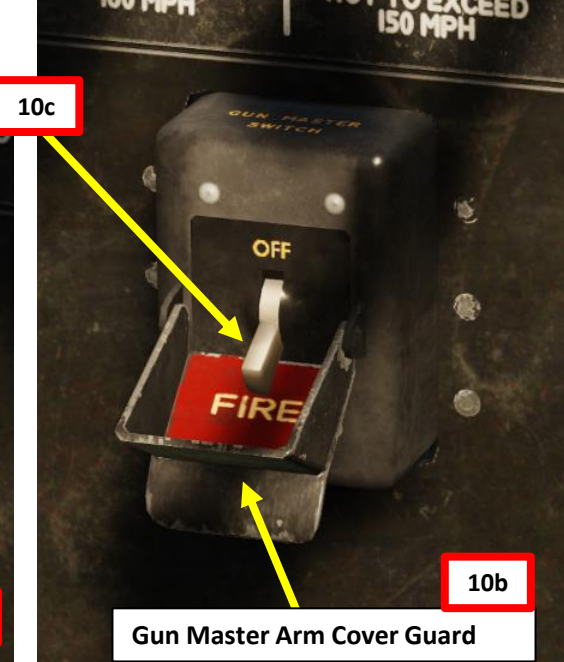
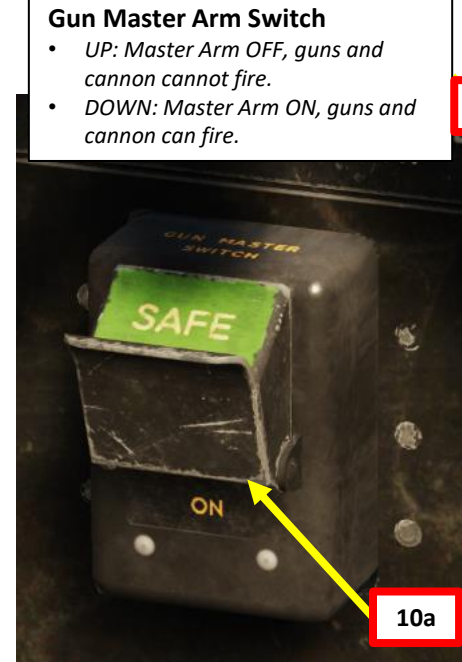

Gun Master Arm Cover Guard

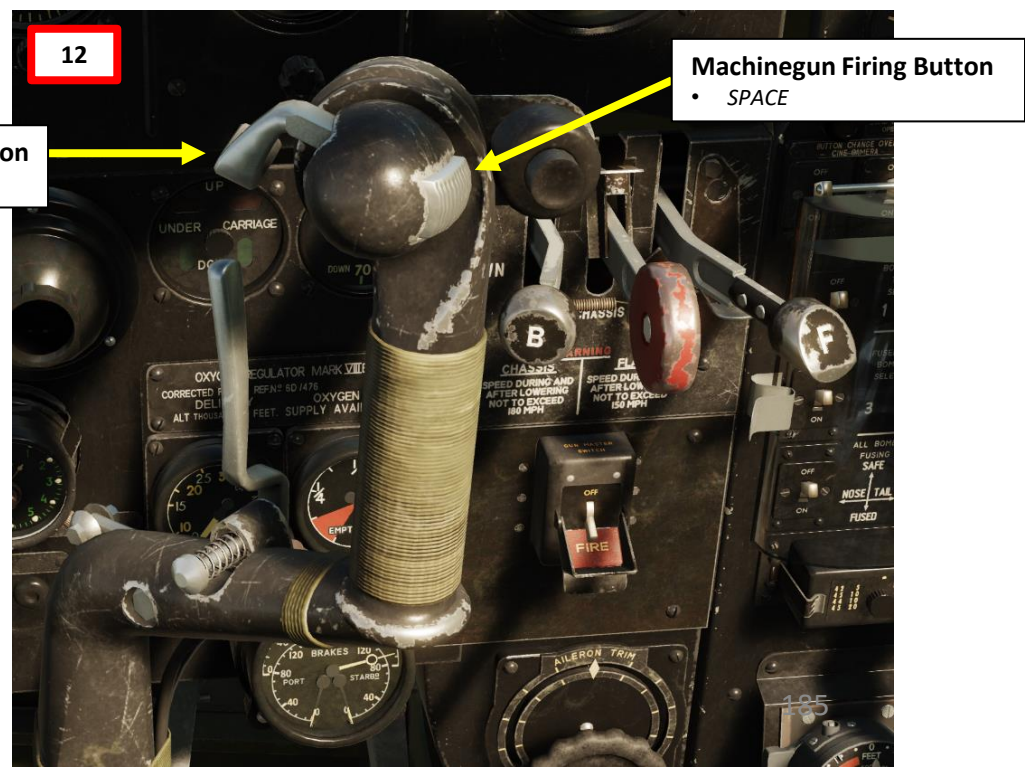

Machinegun Firing Button
• SPACE

12

HISPANO 20 MM CANNONS & BROWNING 0.303 IN MACHINEGUNS



BOMBS – OVERVIEW

The Mosquito could be equipped with a variety of bombs. Here is an overview of the different bomb types:

- **GP:** General Purpose Bomb, with a thick-walled metal casing. GP bombs have less explosive filler than Medium Capacity bombs, but more shrapnel due to the thicker case.
- **MC:** Medium Capacity Bomb, with a thin-walled metal casing. MC bombs have more explosive filler than General Purpose bombs, at the expense of less shrapnel due to the thinner case.
- **SAP:** Semi-Armor Piercing Bomb
- **Short Tail:** Some bombs had their tail shortened in order to fit within the internal bomb bay of the Mosquito.

Note: Delayed fuze bombs are not yet available.

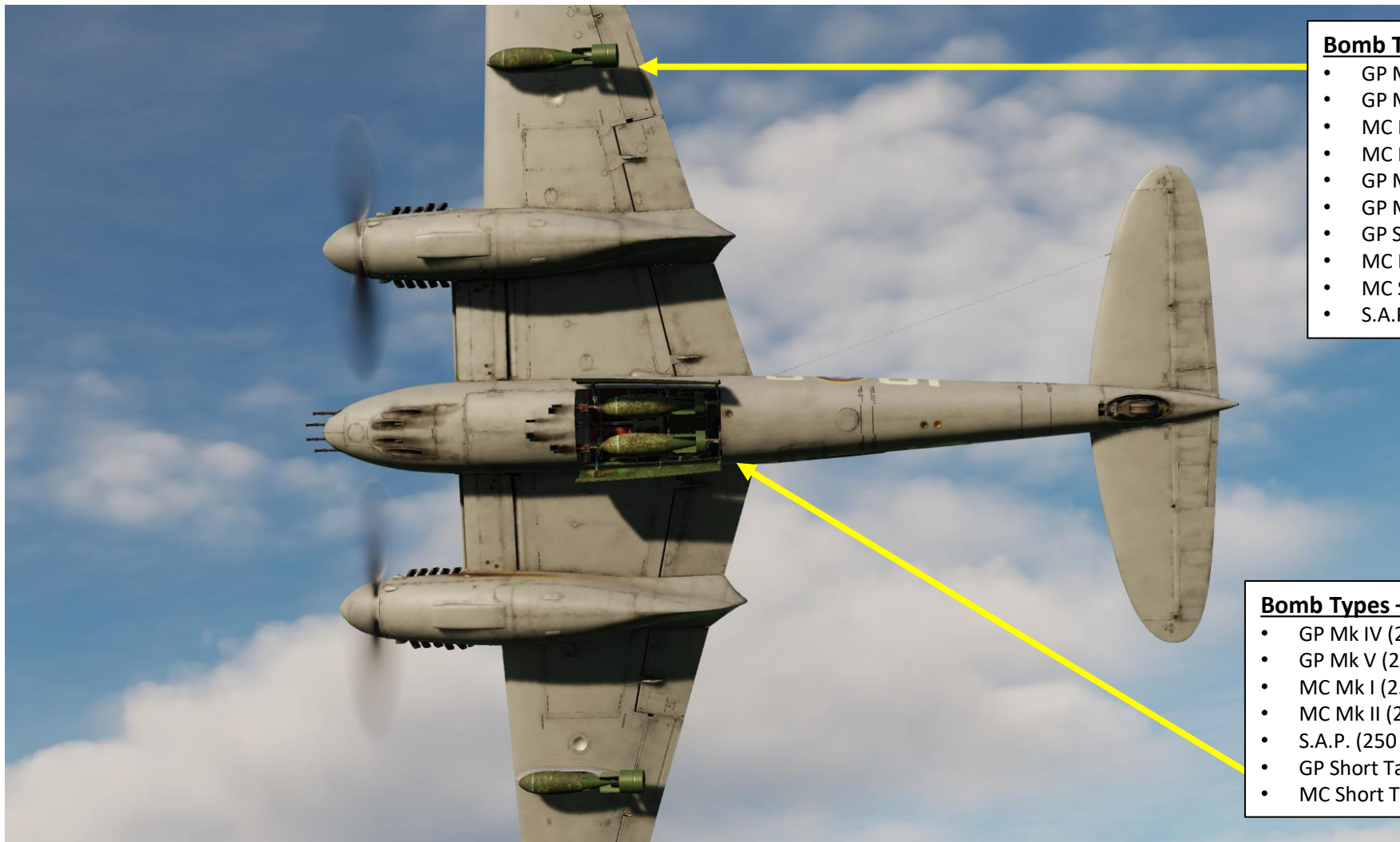

Bomb Types – Wing-Mounted

- GP Mk IV (250 lbs)
- GP Mk V (250 lbs)
- MC Mk I (250 lbs)
- MC Mk II (250 lbs)
- GP Mk IV (500 lbs)
- GP Mk V (500 lbs)
- GP Short Tail (500 lbs)
- MC Mk II (500 lbs)
- MC Short Tail (500 lbs)
- S.A.P. (500 lbs)

Bomb Types – Fuselage Bomb Bay

- GP Mk IV (250 lbs)
- GP Mk V (250 lbs)
- MC Mk I (250 lbs)
- MC Mk II (250 lbs)
- S.A.P. (250 lbs)
- GP Short Tail (500 lbs)
- MC Short Tail (500 lbs)

BOMBS – DIVE BOMBING TUTORIAL

1. Set Reflector Gunsight Power switch to ON (DOWN)
2. Open Bomb Bay Perspex Cover (depress release catch)
3. Set Bombs/Camera Changeover Switch – DOWN (ON)
4. Select desired Bombs with Selector Switches DOWN (SELECTED/ON)
 - a) Wing-Mounted Bombs – Switch 1 for Left/Port Bomb, Switch 2 for Right/Starboard Bomb
 - b) Fuselage Inner Bay Bombs – Switch 3 for Left/Port Bomb, Switch 4 for Right/Starboard Bomb
5. Set Nose Fuzing Switch – DOWN (Fuze ARMED). Most of the bombs used in this tutorial are nose-fuzed.
6. Set Tail Fuzing Switch – DOWN (Fuze ARMED). *Step not applicable since no tail-fuzed bombs are available.*

1 Reflector Gunsight Power Switch

- DOWN: ON
- UP: OFF

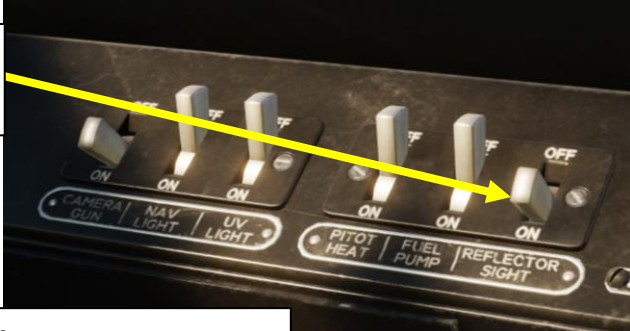

Bombs or Camera Changeover Switch

Sets the function of the Bomb Release & Gun Camera (Guncam) Button

- UP: OFF (Gun Cine Camera Selected, Bombs not Selected)
- DOWN: ON (Bombs Selected, Gun Cine Camera not Selected)

3

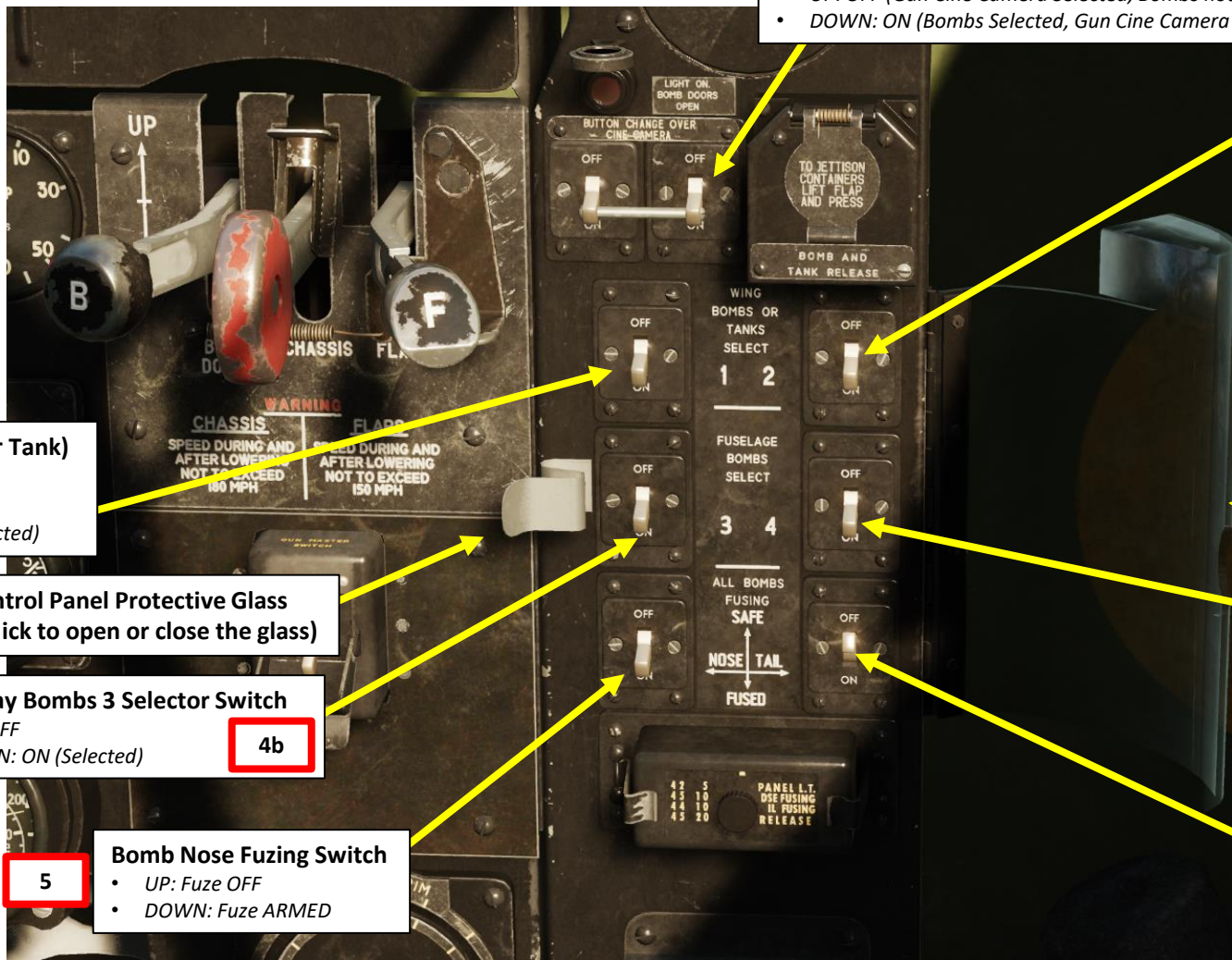

4a Wing Bombs 2 (or Tank) Selector Switch

- UP: OFF
- DOWN: ON (Selected)

4a

4a Wing Bombs 1 (or Tank) Selector Switch

- UP: OFF
- DOWN: ON (Selected)

2a Bomb Control Panel Protective Glass Handle (click to open or close the glass)

2b Bomb Control Panel Protective Glass

2b

4b Inner Bay Bombs 3 Selector Switch

- UP: OFF
- DOWN: ON (Selected)

4b

4b Inner Bay Bombs 4 Selector Switch

- UP: OFF
- DOWN: ON (Selected)

4b

5 Bomb Nose Fuzing Switch

- UP: Fuze OFF
- DOWN: Fuze ARMED

6 Bomb Tail Fuzing Switch

- UP: Fuze OFF
- DOWN: Fuze ARMED

6

BOMBS – DIVE BOMBING TUTORIAL

7. Flip Bomb Doors Warning Light Cover – UP
8. Hold Bomb Door Lever DOWN to open bomb bay doors. Max Bomb Extension Safety Speed is 350 mph.
9. When bomb bay doors are open, the Bomb Doors Warning Light should illuminate and the Bomb Door Lever should return to the NEUTRAL (Middle) Position.

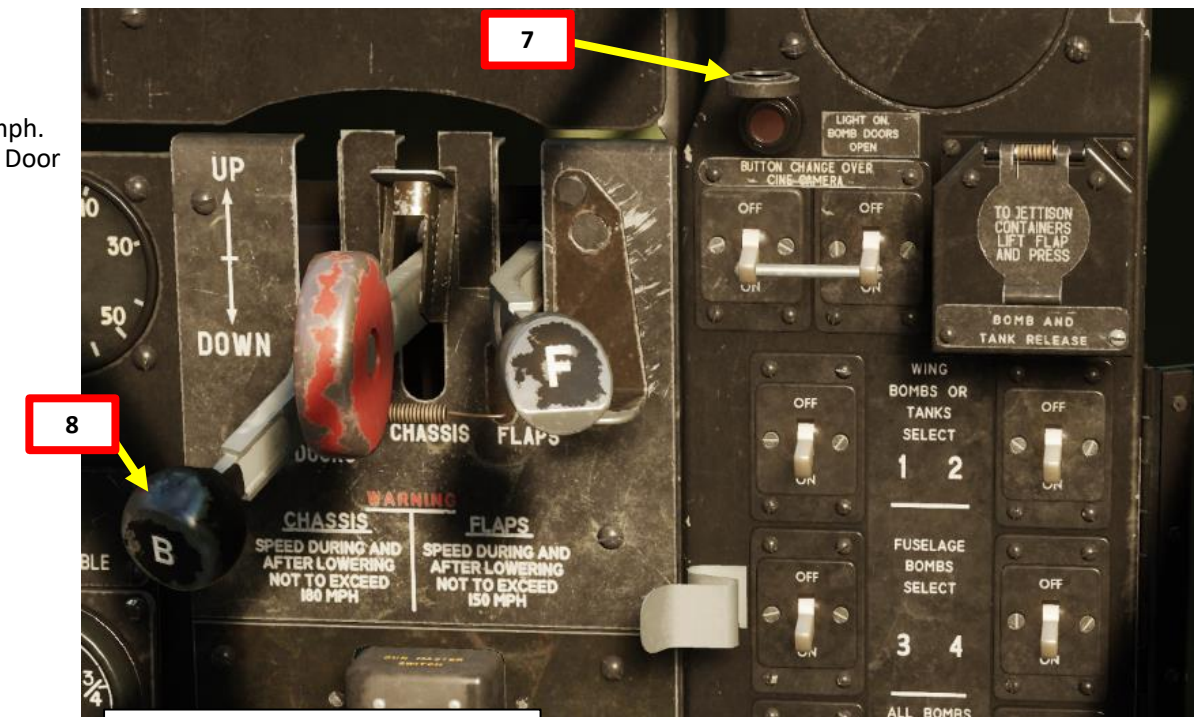

9 Bomb Doors Warning Light
Illuminates when bomb doors are OPEN





BOMBS – DIVE BOMBING TUTORIAL

10. Approach the target by flying level at an altitude between 5000 and 6000 ft, with an airspeed between 220 and 230 mph.
11. When the target disappears under the engine, perform a gentle turn under the horizon in the direction of the target.
12. While turning, regulate speed so that the target remains visible. This turn has to be very steady and made without excessive use of the rudder.



BOMBS – DIVE BOMBING TUTORIAL

13. The gunsight is aligned with the guns, which makes it difficult to see when sitting on the pilot seat (which isn't aligned with the gunsight). Lean on the gunsight and fit the target wings within your gunsight.
 - a) Leaning on the gunsight can be done in numerous ways (as per the Special Options tab), but my recommended method is the *"Shift to aim when shoulder harness is released"* option.
 - b) With this method, set a binding to "Shoulder Harness – Release/Lock". When you release the shoulder harness (lever UP), the pilot will automatically lean on the gunsight.
14. Throttle back at idle power and perform a dive between 30 and 40 degrees.
15. Line up the target with the center of the gunsight reticle. Make sure the aircraft is not slipping or the bombs may collide after bomb drop and detonate in the air.
16. Pull lead to bring the target slightly so that the target will cross the bottom arc of the reflector sight.
17. When target is lined up under the bottom arc of the reflector sight and aircraft is at an altitude of 1500 ft, release bombs by pressing the Bomb Release button on the stick ("**RSHIFT+SPACEBAR**" binding). All bombs selected will drop simultaneously.

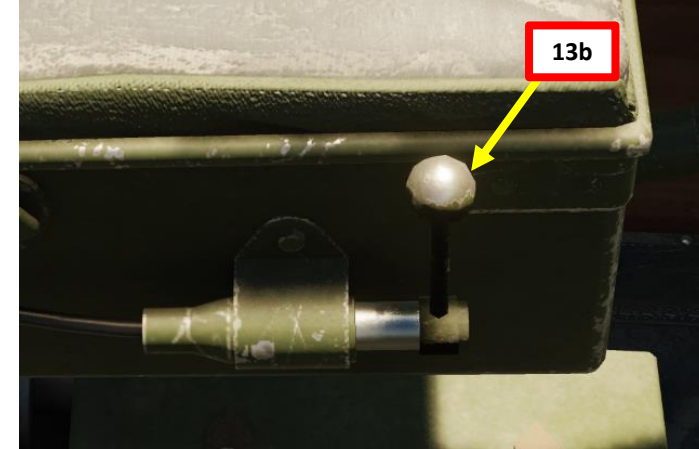

Bomb Release & Gun Camera (Guncam) Button
 • **RSHIFT+SPACE**
 The function of the button depends of the position of the Bombs or Camera Changeover Switch

BOMBS – DIVE BOMBING TUTORIAL

18. Apply full power and pull away from the blast while maintaining level flight. This will allow you to get out as quickly as possible from the orbit of enemy flak.
19. Close the bomb bay doors by holding the Bomb Door Lever UP.
20. When bomb bay doors are closed, the Bomb Doors Warning Light should extinguish and the Bomb Door Lever should return to the NEUTRAL (Middle) Position.
21. After having travelled enough distance, start climbing. Climbing immediately after the release of bombs was one of the most common mistakes and resulted in:
 - Unnecessary danger to the pilot from the enemy flak
 - Black-out
 - Wing wrinkling

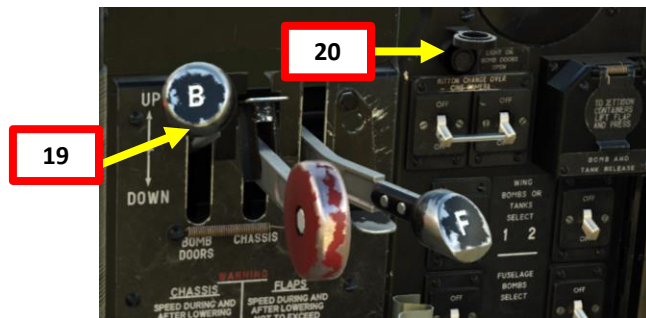



BOMBS – DIVE BOMBING TUTORIAL

Iain Christie (Sidekick) has a great demonstration on how to dive bomb in the Mosquito:
<https://youtu.be/46xe-aESMYs>

Bombing profiles are not standard and vary from pilot to pilot.

“Squinto” (also known as “TAW Prof”) created some great Bomb Depression Tables, which are available here:
<https://www.digitalcombatsimulator.com/fr/files/3319987/>

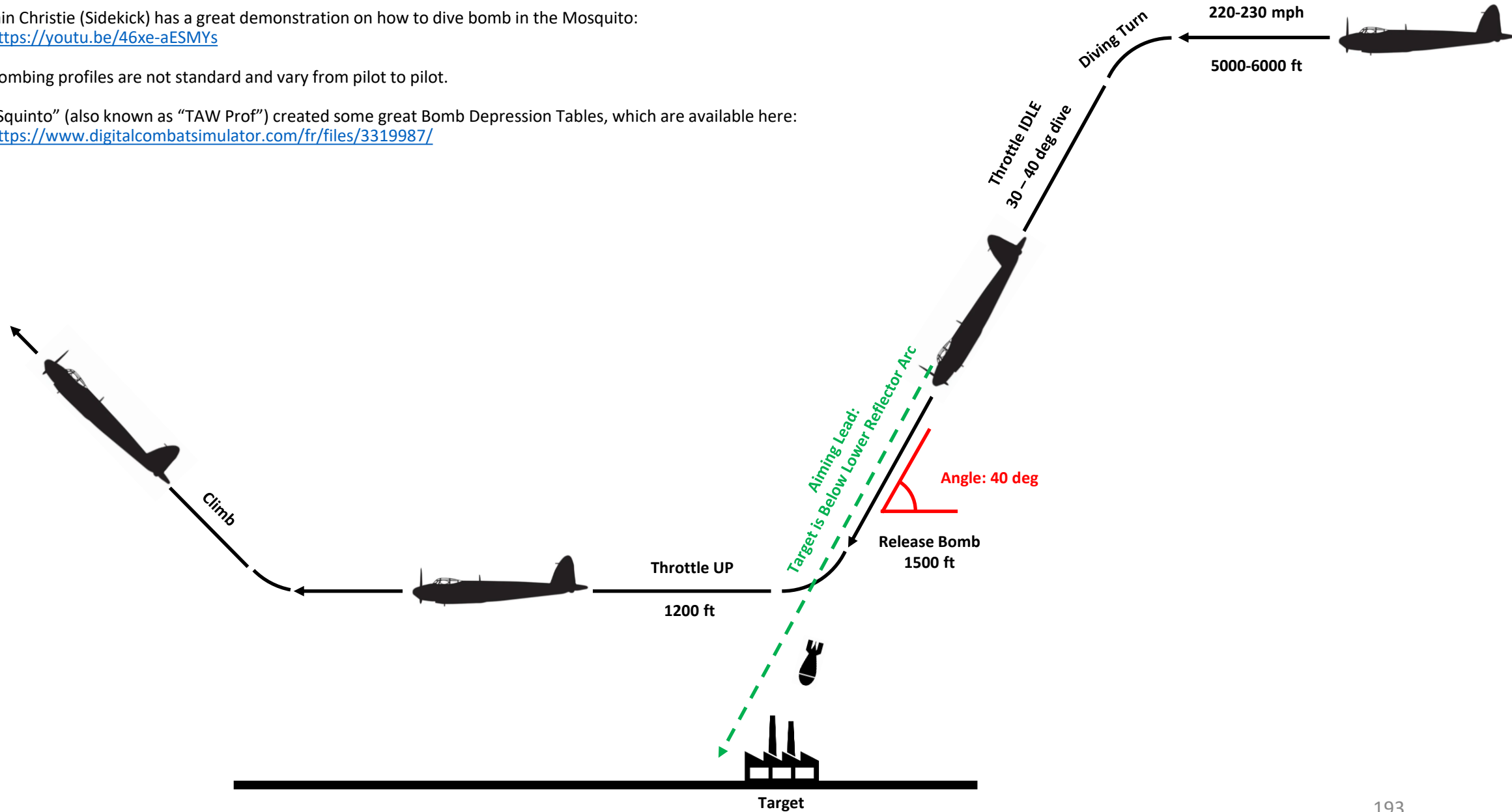

BOMBS – LOW LEVEL BOMBING TUTORIAL

- Delayed fuzes for low level bombing are not yet available.



BOMBS – SKIP BOMBING TUTORIAL

- Delayed fuzes for skip bombing are not yet available.



RP-3 ROCKET PROJECTILES (3 IN)

RP-3 Rockets come with either 25 lbs warheads or 60 lbs warheads. You can equip the following types:

- RP-3 25 lbs AP Mk I: Armor-Piercing variant with a 25 lbs warhead, used against ships.
- RP-3 60 lbs F No. 1 Mk I: Fragmentation / High Explosive variant with a 60 lbs warhead, used against infantry and light vehicles.
- RP-3 60 lbs SAP No. 2 Mk I: Semi-Armor Piercing variant with a 60 lbs warhead, used against a mix of soft targets and light vehicles.



RP-3 AP Rocket (25 lbs)



RP-3 SAP Rocket (60 lbs)



RP-3 Rocket (25 lbs)

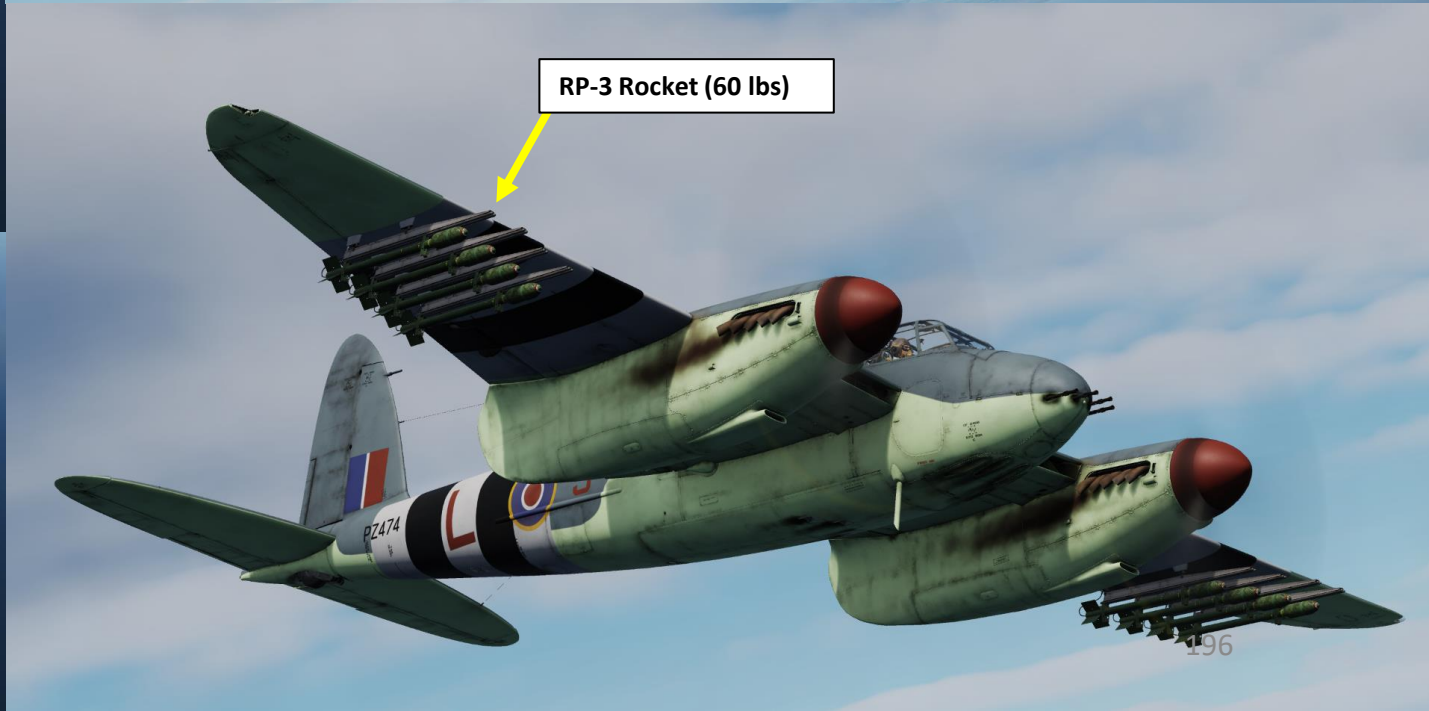

RP-3 Rocket (60 lbs)

RP-3 ROCKET PROJECTILES (3 IN)

1. Set Reflector Gunsight Power Switch – ON (DOWN)
2. Set Rocket Master Switch – ON (RIGHT)
3. Set Rocket Salvo Mode Selector Switch – As desired
 - DOWN (ON) fires all rockets when trigger is pressed
 - UP (OFF) fires a single rocket on each wing
4. Press Rocket Rail Step Button to select the rocket rail that you want to fire first in the salvo, or in case you encounter a rocket misfire or a damaged rail. The Rocket Counter indicates the number of the rail selected to fire the rocket, with “1” being the outermost rail and “4” being the innermost rail.

Reflector Gunsight Power Switch

- DOWN: ON
- UP: OFF

1



Rocket Trigger Button (LALT+SPACEBAR)

- Trigger is located on the right throttle

Rocket Master Switch

- LEFT: OFF
- RIGHT: ON

2

4a

Rocket Rail Step Button

Rocket Counter

4b

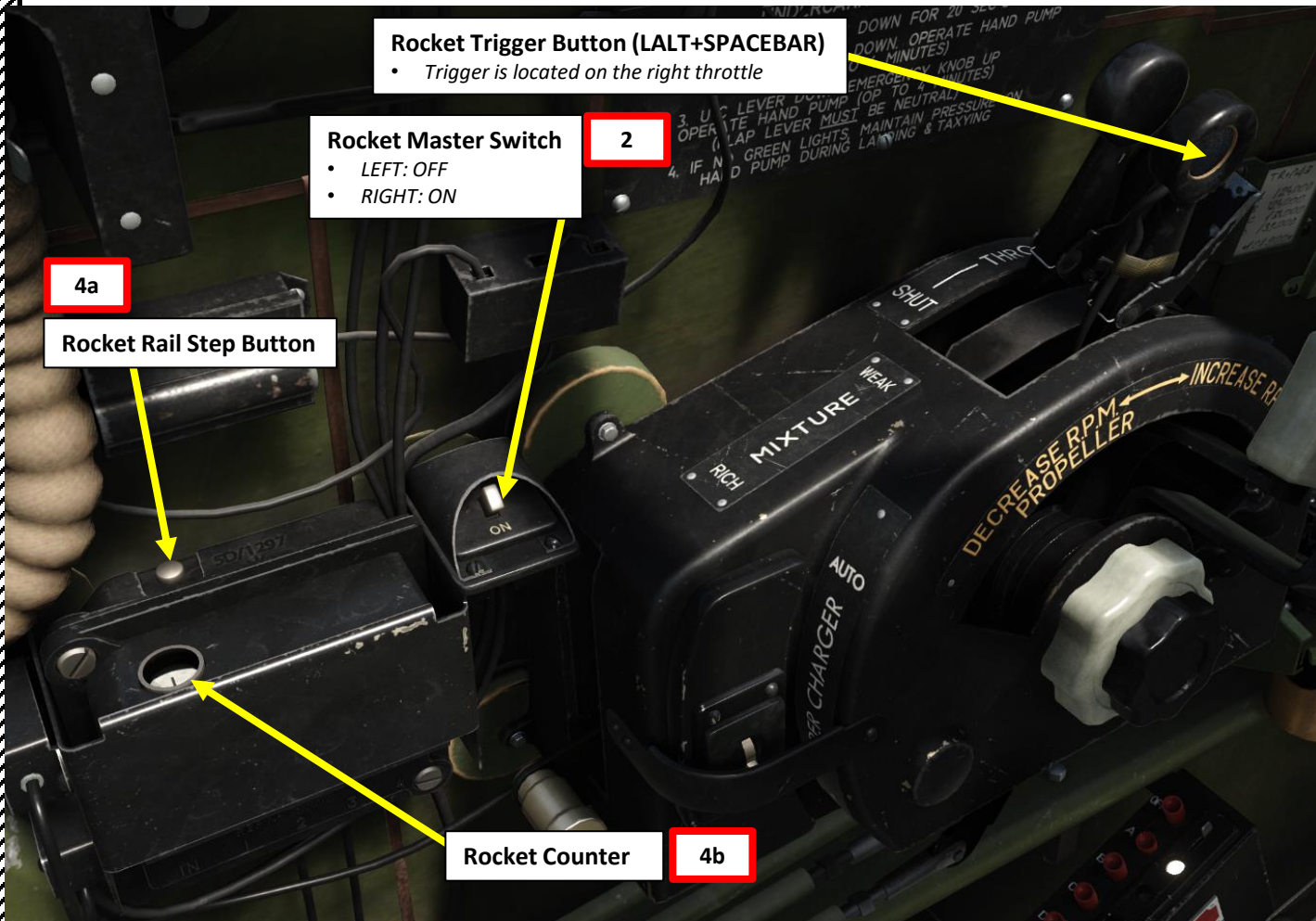

Rocket Salvo Mode Selector Switch

- DOWN: ON (Rockets fire in Salvo)
- UP: OFF (Rockets fire in pairs: one per wing)

3



RP-3 ROCKET PROJECTILES (3 IN)

5. There are many different attack profiles, but typically I would recommend starting your attack run from 3000 ft above ground level.
6. The gunsight is aligned with the guns, which makes it difficult to see when sitting on the pilot seat (which isn't aligned with the gunsight). Lean on the gunsight and fit the target wings within your gunsight.
 - a) Leaning on the gunsight can be done in numerous ways (as per the Special Options tab), but my recommended method is the "Shift to aim when shoulder harness is released" option.
 - b) With this method, set a binding to "Shoulder Harness – Release/Lock". When you release the shoulder harness (lever UP), the pilot will automatically lean on the gunsight.
7. When you have the target in sight, roll in and reduce throttle to maintain a 20 deg dive with an airspeed near 250 mph.
8. Line up the target with the center of the reticle.
 - *Note: Keep in mind that there are other available reference points and techniques to pull lead before launching rockets.*
9. Make sure you are not slipping when aiming for the target.

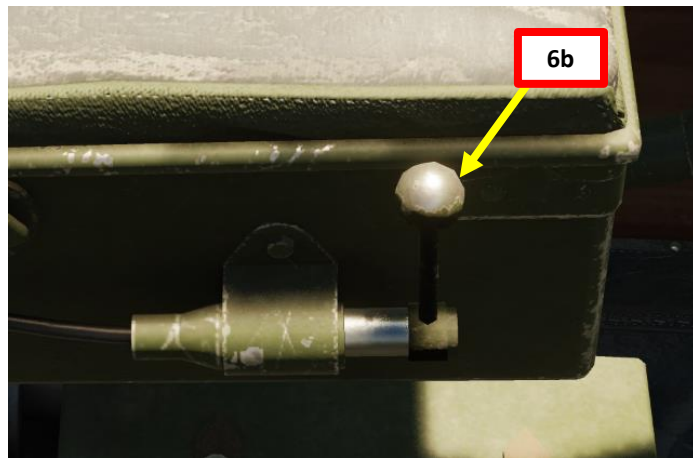

RP-3 ROCKET PROJECTILES (3 IN)

10. Pull lead to bring the target slightly so that the target will cross the bottom arc of the reflector sight.
11. When you are 1000 ft away from the target, fire rockets by pressing the Rocket Trigger Button (LALT+ SPACEBAR), which is located on the right throttle. Rockets will fire from the outer rails first, then proceed to the inner rails.
12. Apply full power and pull away from the blast. Recovery altitude should be about 75 ft above ground level.



11

Rocket Trigger Button (LALT+SPACEBAR)

- Trigger is located on the right throttle



Bottom Arc of Reflector Sight



SECTION STRUCTURE

- 1 – Radio Systems Overview
- 2 – Radio Frequency Signals Spectrum
- 3 – SCR-522 (TR1143) VHF Radio
 - 3.1 – Components
 - 3.2 – Transmission Tutorial
- 4 – T1154 & R1155 Radio Set
 - 4.1 – T1154 Transmitter & R1155 Receiver Components
 - 4.2 – Transmission & Reception Tutorial (HF with Fixed Antenna)
 - 4.3 – Transmission & Reception Tutorial (MF with Trailing Antenna)

1 – RADIO SYSTEMS OVERVIEW

The Mosquito allows both the pilot and the navigator to communicate on the radio.

The pilot can use the **SCR-522** Radio set (also referred as **TR1143**), which is a typical radio box installed on fighter planes with four preset frequencies.

The navigator, on the other hand, can use the **T1154** Radio Transmitter to choose what frequency to communicate on, and the **R1155** Radio Receiver set to choose what frequency the radio is tuned to in order to listen to a radio broadcast within a specific frequency band.

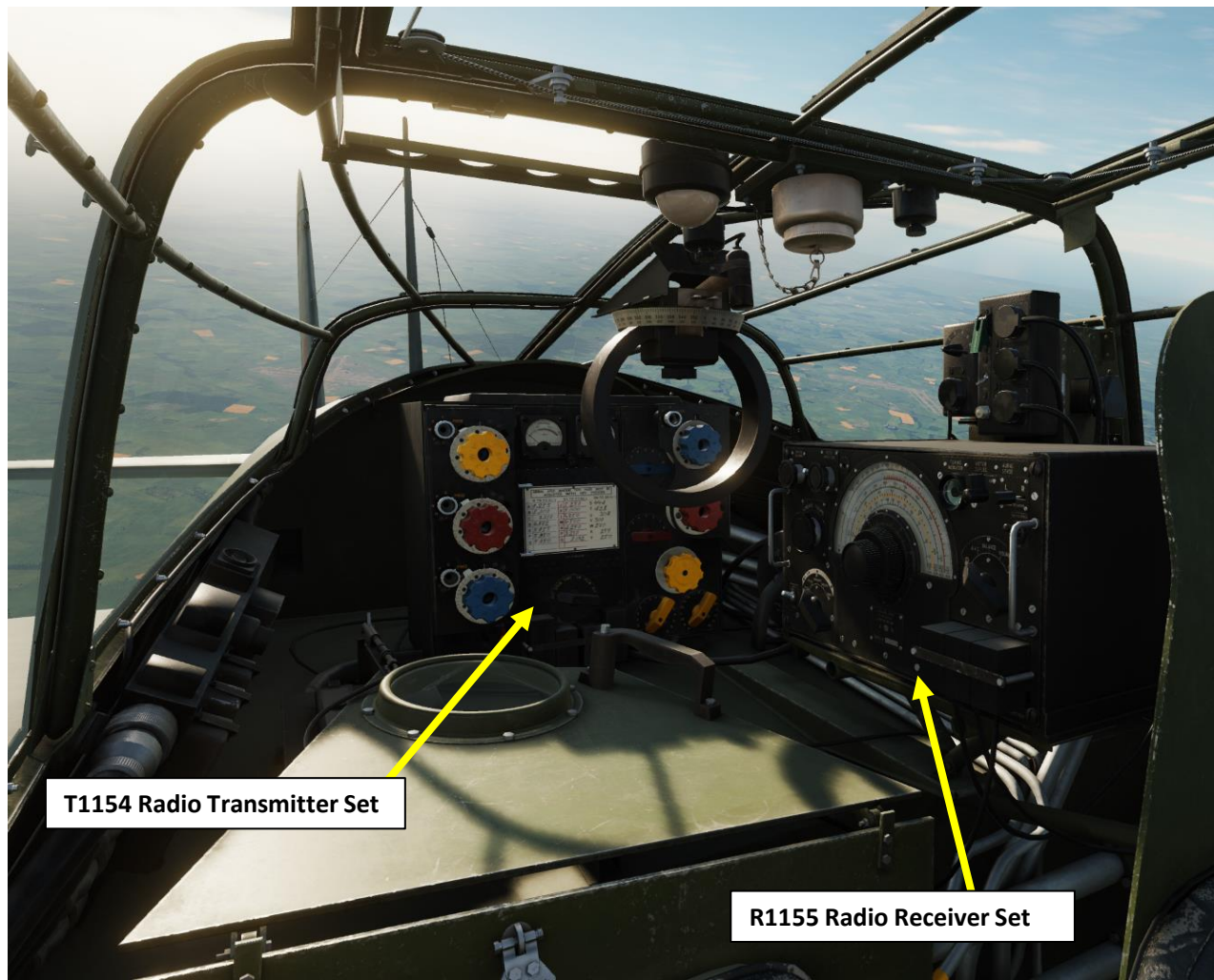

T1154 Radio Transmitter Set

R1155 Radio Receiver Set



T.1154 & R.1155 Radio Set Power Switches

Navigator Push-to-Talk Button

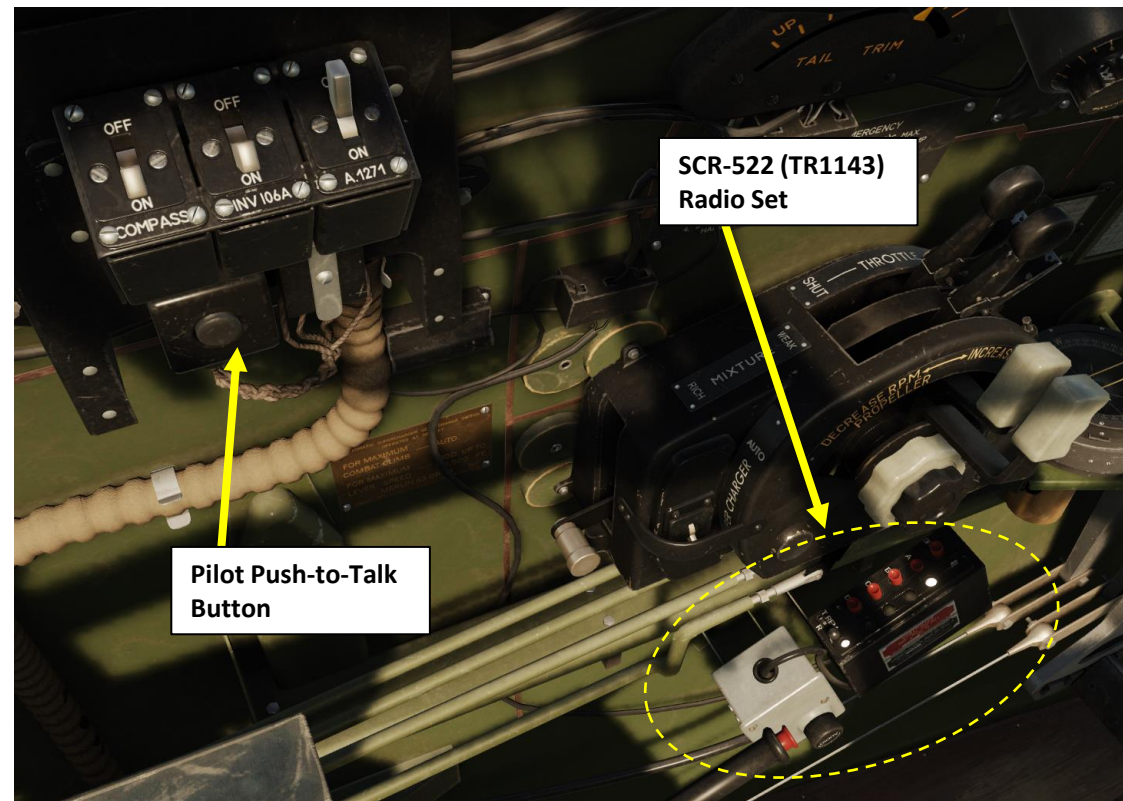

Pilot Push-to-Talk Button

SCR-522 (TR1143) Radio Set

1 - RADIO SYSTEMS OVERVIEW

T.1154 & R.1155 Inter-Unit Cabling

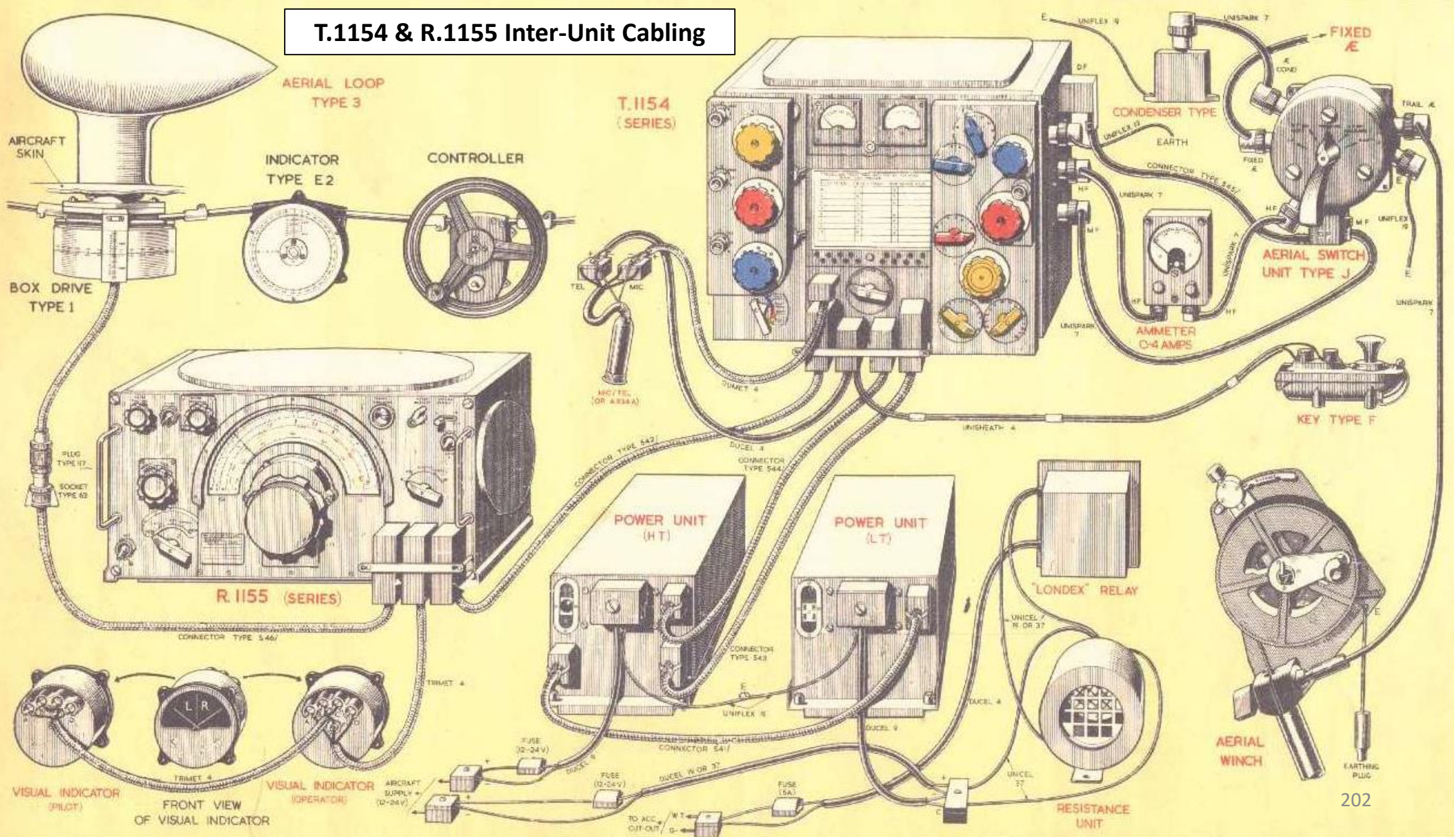

2 – RADIO FREQUENCY SIGNALS SPECTRUM

The Mosquito's radios can pick up a number of different frequency bands. This is the kind of radio set you would have installed on other long-range bombers like the Lancaster. An interesting question to ask would be... what were these frequencies used for? Luckily, a gentleman called John Fallows (VE6EY) wrote an interesting article titled "WW2 Signals Spectrum – A Quick Survey", which explains what you could expect to hear on the radio bands between 1939 and 1945.

See this link for reference: <http://play.fallows.ca/wp/radio/shortwave-radio/ww2-signals-spectrum-detail/>

Signal Spectrum Below 2 MHz (VLF, LF, MF)

(covered by the R1155 radio receiver range and by the T1154 radio transmitter yellow range 3)

Low and medium frequency waves (LF and MF) provide reliable communication up to 1,000 km by ground wave, especially over water. High power is required to overcome atmospheric noise, especially in tropical areas. Good skywaves can span oceans. Very long frequency waves (VLF) have the added benefit of penetrating into salt water for a short distance.

Navies used high power LF to communicate with ships at 100 – 500 kHz. Germany used LF for naval and air force homing and navigation, as well as some high power VLF for sending instructions to submarines, such as "Goliath". Goliath was a VLF transmitter used by the Kriegsmarine U-boats and was capable of transmitting power between 100 and 1000 kW. Also, LF was used by armored forces for regimental signals. Most transmissions were done by Morse code, a method used in telecommunication to encode text characters as standardized sequences of two different signal durations, called *dots* and *dashes*, or *dits* and *dahs*.

Signal Spectrum From 2 to 12 MHz (Lower HF)

(covered by the R1155 radio receiver range, and by the T1154 radio transmitter blue range 1 and red range 2)

Lower HF frequencies were the work horse for military communications over all distances, especially at night and during winter when absorption is lower. Both ground and sky waves were used, and "skip zones" were avoided by NVIS arrangements (Near Vertical Incidence Skywaves). All forms of modulation were used including W/T (wireless telegraphy), R/T (radio telephony) and data. U-boats used 10 and 12 MHz for long distance communication at night. Luftwaffe did long range navigation, and artillery and infantry ran low power communications. Some V1 missiles sent telemetry on these frequencies.

The Allies ran AM infantry man-pack, walkie talkies and mobile rigs on 5 – 9 MHz. British tanks communicated over 2-6 MHz in the early stages of the war. During the Battle of Britain, Spitfires used 5 MHz for air-to-air and air-to-ground. Interestingly, during this period, German fighters used R/T while bombers used W/T. Even though they were on similar frequencies, they could not communicate with each other during the air battles.

Long and short distance communication by warships was common in 2-5 MHz. LORAN (Long-Range Navigation) navigation showed up at 2 and 11 MHz, which was a hyperbolic radio navigation system developed in the United States. It was similar to the UK's GEE system but operated at lower frequencies in order to provide an improved range up to 1,500 miles (2,400 km) with an accuracy of tens of miles. Fun fact: this was also the spectrum used by most spy suitcase radios.

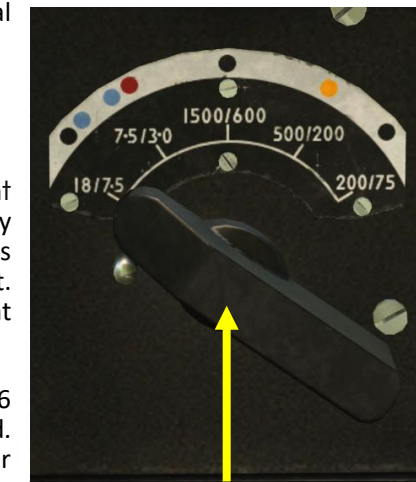
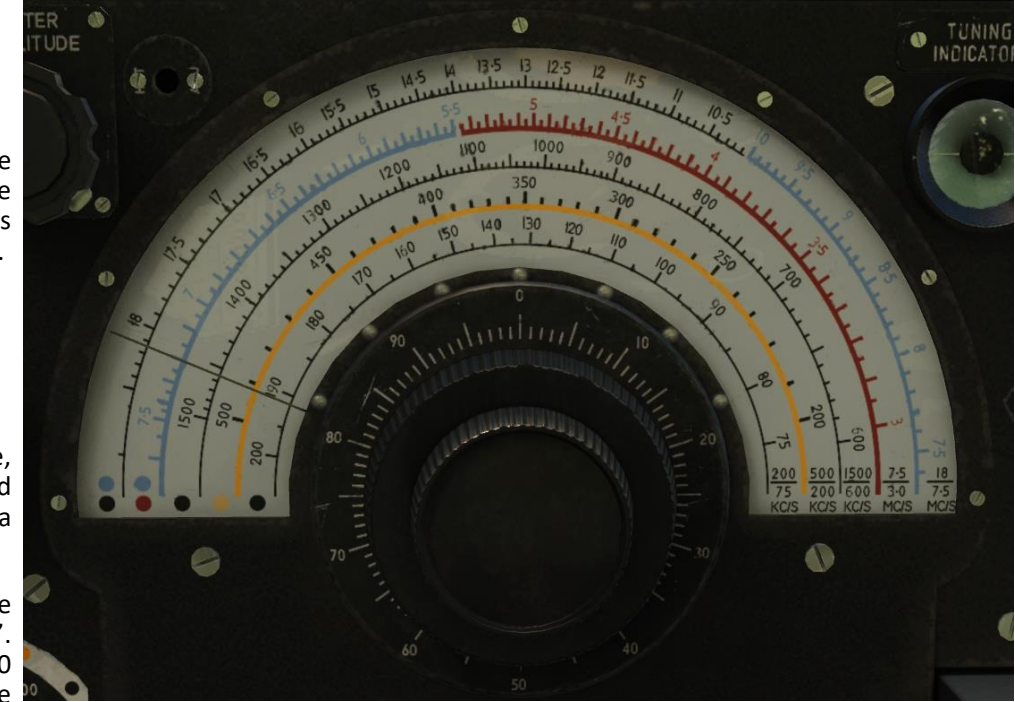

R1155 Radio Receiver Set Frequency Range Switch

- **18/7.5:** Range from 18.5 MHz to 7.5 MHz (H/F)
- **7.5/3.0:** Range from 7.5 MHz to 3.0 MHz (H/F)
- **1500/600:** Range from 1500 KHz to 600 KHz (M/F)
- **500/200:** Range from 500 KHz to 200 KHz (M/F)
- **200/75:** Range from 200 KHz to 75 KHz (M/F)

T1154 Radio Frequency Range Selector (S1)

- **Blue Range 1:** 10.0 MHz to 5.5 MHz
- **Red Range 2:** 5.5 MHz to 3.0 MHz
- **Yellow Range 3:** 500 KHz to 200 KHz

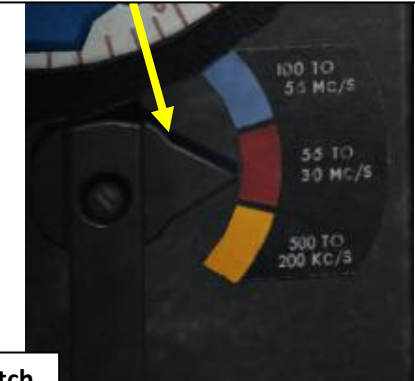



2 – RADIO FREQUENCY SIGNALS SPECTRUM

Signal Spectrum From 12 to 25 MHz (Upper HF)

(HF covered by the R1155 radio receiver range, but not covered by T1154 radio transmitter)

During sunspot highs (a natural phenomenon that occurs due to magnetic activities on the Sun's surface), certain HF frequencies are mainly long distance using skywaves. In radio communication, "skywave" (or "skip") refers to the propagation of radio waves reflected or refracted back toward Earth from the ionosphere, an electrically charged layer of the upper atmosphere. Since it is not limited by the curvature of the Earth, skywave propagation can be used to communicate beyond the horizon, at intercontinental distances. It is mostly used in the shortwave frequency bands.

Interestingly, both the Allied and German militaries tried a lot of short range communication within this frequency band. The venerable Sherman tank did its R/T in upper HF, as did much of German armor. Wehrmacht short range infantry and close support showed up at 20 MHz. Both Japanese and German naval forces did long distance around 16 MHz. Britain's Chain Home radar system blanketed frequencies between 20-30 MHz.

Signal Spectrum From 25 to 75 MHz (Lower VHF)

(Not covered by the DCS Mosquito radios)

The Lower VHF band wave reception is line-of-sight over distances up to 100 km. Some skip can occur during sunspot highs, but mostly the cause of longer distances is ducting. Atmospheric ducting is a mode of propagation of electromagnetic radiation, usually in the lower layers of Earth's atmosphere, where the waves are bent by atmospheric refraction. In over-the-horizon radar, ducting causes part of the radiated and target-reflection energy of a radar system to be guided over distances far greater than the normal radar range. It also causes long distance propagation of radio signals in bands that would normally be limited to line of sight.

Americans were fast with the development of FM tactical communications, especially to mitigate ignition noise in vehicles. FM backpacks used 28-52 and 40-48 MHz. Popular vehicular FM covered 20-28 MHz. Similar frequency use occurred with German tanks and low power infantry backpacks, although more on AM. Navy and U-Boats did short range voice. American navy used this band for Talk Between Ships (tactical). Sharing this band was navigation. German bombing beams ran on 30-35 and 60 MHz. Meanwhile, the Allies GEE Bomber Navigation system covered 20-85 MHz.

Signal Spectrum From 75 MHz and Up (VHF, UHF)

(VHF covered by the SCR-522 radio)

By the end of the Battle of Britain, the RAF moved to 100-124 Mhz. British ground forces took on low power R/T on 229-241 MHz. The Germans used UHF for military phone networks and infantry truck mounted voice and teletype.

But mostly, it was radar. Early US radar operated on 105 and 205 MHz. (That Pearl Harbor radar station in the movie was was the SCR-270 on 105 Mhz.) These frequencies were also used for gun control. Chain Home Low operated at 200 MHz during Battle of Britain. Early German radar was also on these frequencies, while Soviets used 75 MHz. OBOE navigational transponders were on 200 MHz.

3 – SCR-522 (TR1143) VHF RADIO

3.1 – COMPONENTS

The Mosquito is equipped with a SCR-522 type VHF radio, which is an American-built TR1143 british radio manufactured as part of the Lend Lease agreement between the United Kingdom and the United States. Radio frequencies are preset in the mission editor in 4 different channels and cannot be tuned manually during flight; you have to use these 4 preset frequencies.

**RADIO FREQUENCY RANGE:
100 - 156 MHz**

Maximum Radio Range

Altitude, Feet	Range, Miles
1000	30
3000	70
5000	80
10000	120
15000	150
20000	180

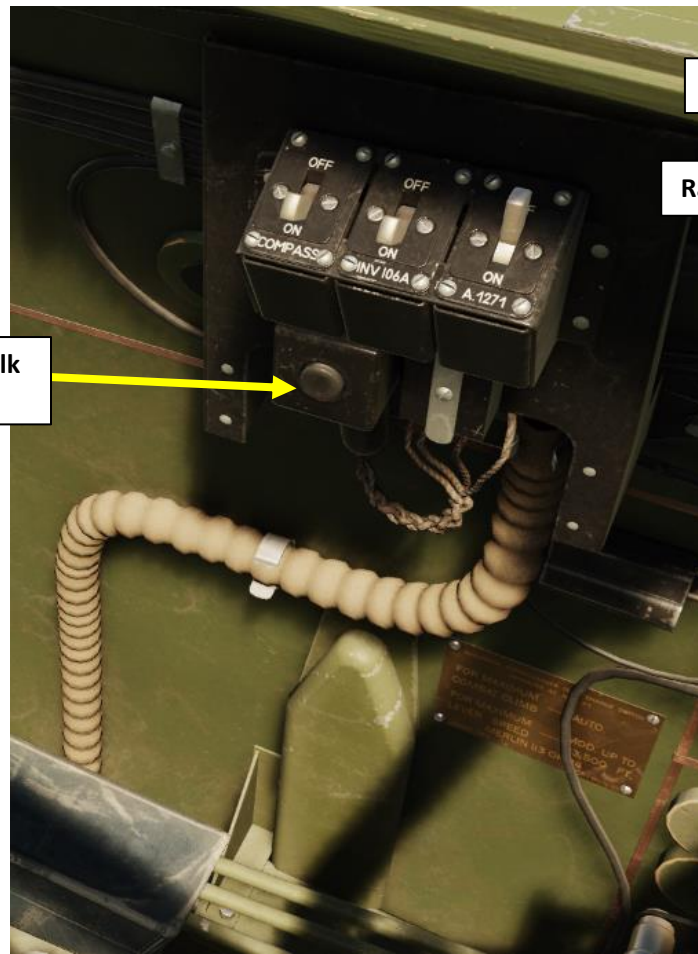
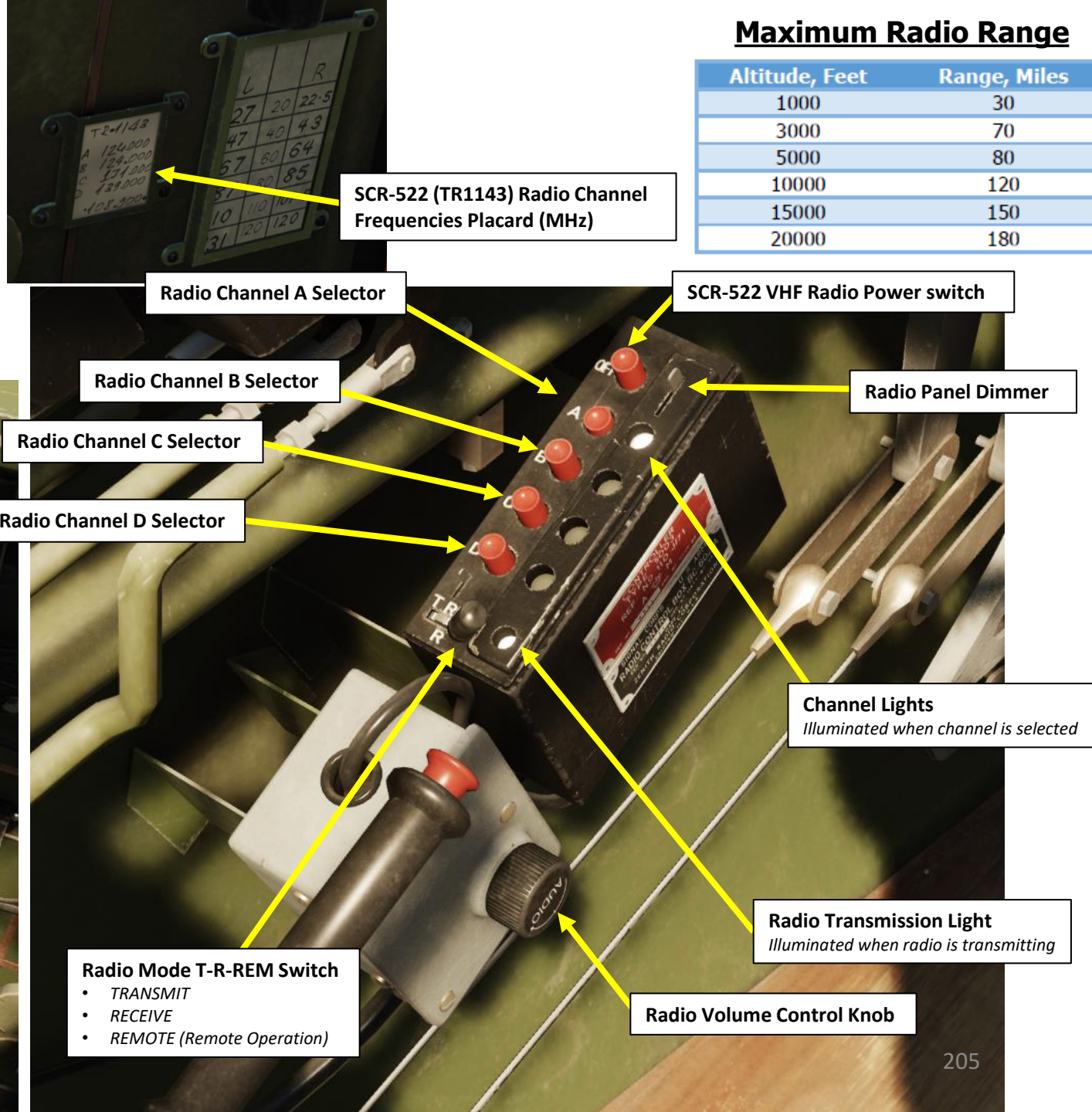

3 – SCR-522 (TR1143) VHF RADIO

3.2 – TRANSMISSION TUTORIAL

To use the SCR-522 radio:

1. Set the radio transmit-receive switch to REM (Remote Operation)
2. Select desired channel (A, B, C or D)
3. Adjust Volume knob – As required
4. Press the “COMM – Push to Talk” binding “RALT+ /” to transmit.

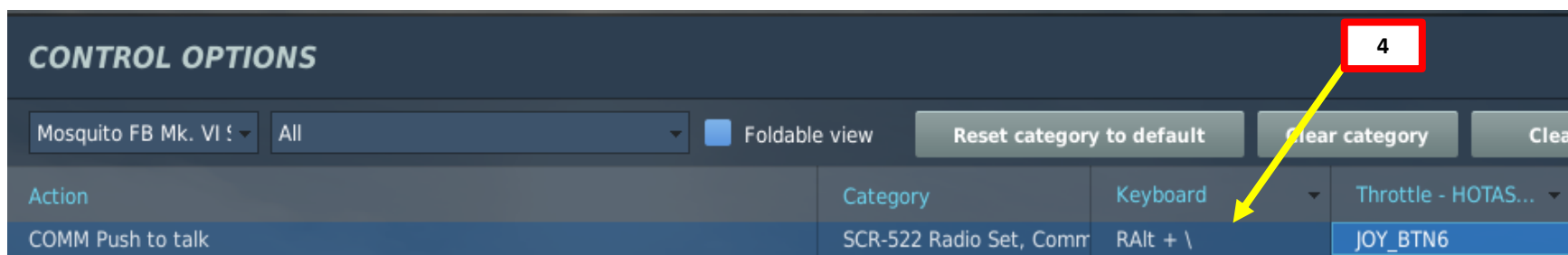
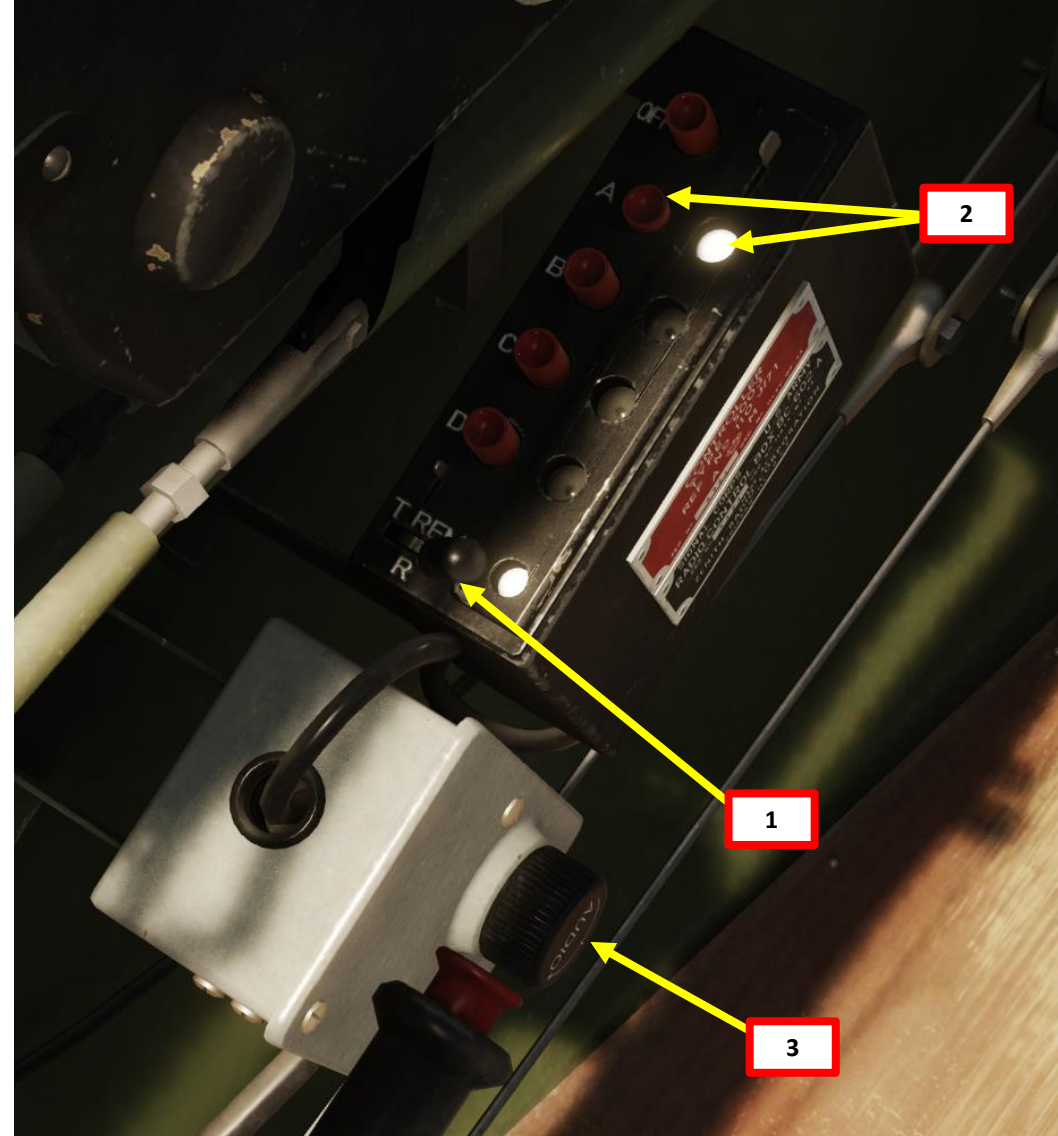
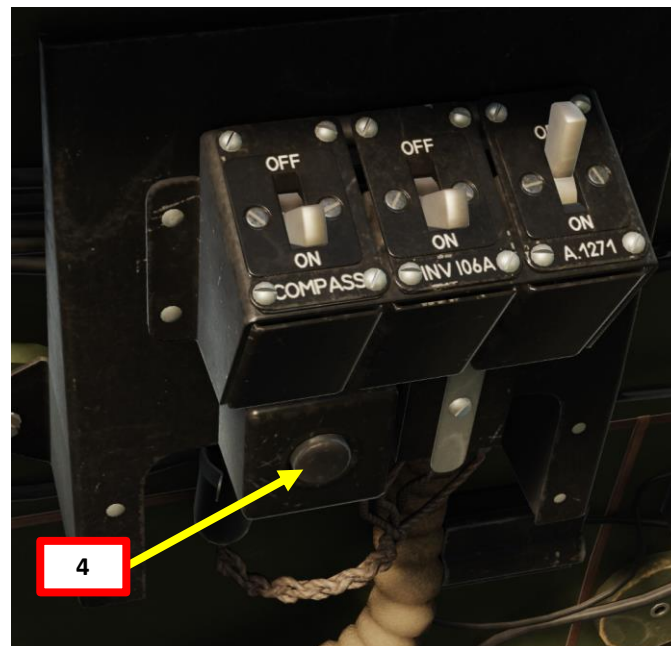

3 – SCR-522 (TR1143) VHF RADIO

3.2 – TRANSMISSION TUTORIAL

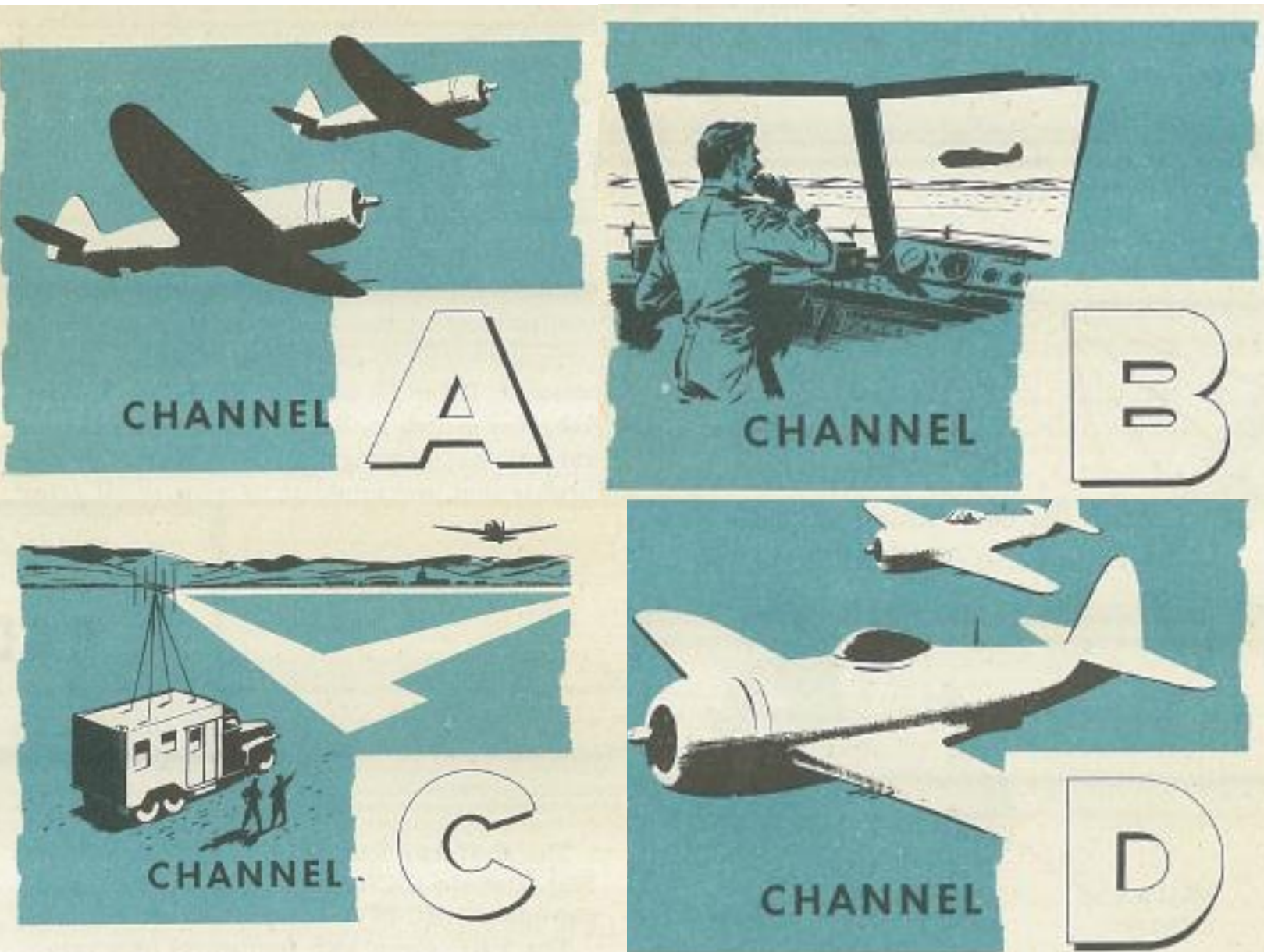

Channel A:

- Plane-to-plane communication on local flights
- Communication with controller in your own region.

Channel B:

- Common to all VHF-equipped control towers. It is normally used to contact the control tower for takeoff and landing instructions

Channel C:

- Frequently used in contacting homing stations

Channel D:

- Plane-to-plane contact between a pilot practicing fighter instrument flying and his safety pilot.
- Normally used for plane-to-ground contact with D/F (Directional Finding) stations. The pip-squeak (contactor), used in conjunction with the D/F fixing provides controllers and intercepts officers with an accurate minute-by-minute position report of your plane. The contactor clock consists of a dial and two switches.

4 – T1154 & R1155 RADIO SET

4.1 – T1154 TRANSMITTER & R1155 RECEIVER COMPONENTS

The navigator can access the rear compartment and use the R1155 receiver to select what radio frequency to receive and the T1154 transmitter to select what radio frequency to transmit on.



T1154 Radio Transmitter Set

R1155 Radio Receiver Set

4 – T1154 & R1155 RADIO SET

4.1 – T1154 TRANSMITTER & R1155 RECEIVER COMPONENTS

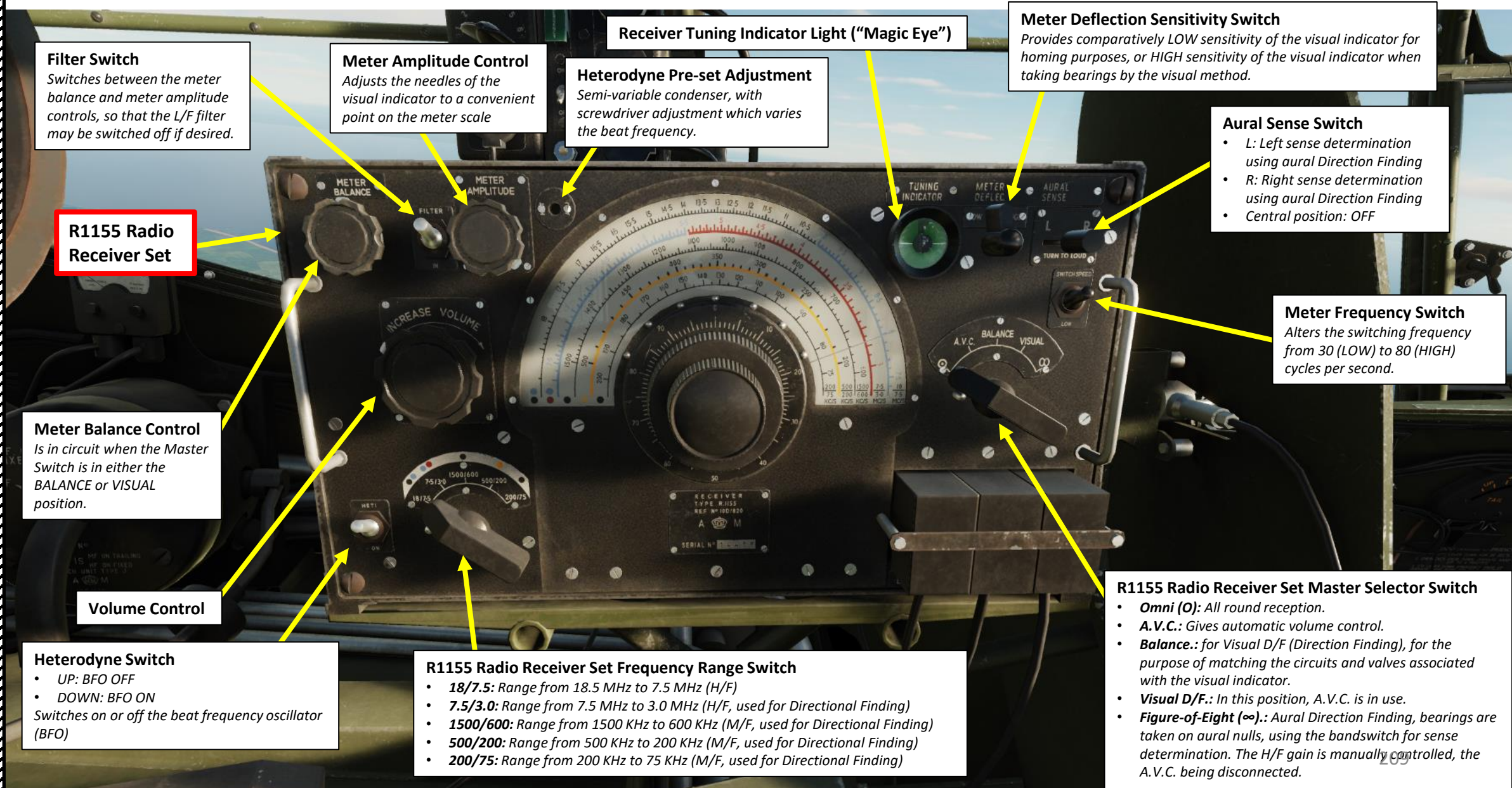

Filter Switch
Switches between the meter balance and meter amplitude controls, so that the L/F filter may be switched off if desired.

Meter Amplitude Control
Adjusts the needles of the visual indicator to a convenient point on the meter scale

Heterodyne Pre-set Adjustment
Semi-variable condenser, with screwdriver adjustment which varies the beat frequency.

Receiver Tuning Indicator Light ("Magic Eye")

Meter Deflection Sensitivity Switch
Provides comparatively LOW sensitivity of the visual indicator for homing purposes, or HIGH sensitivity of the visual indicator when taking bearings by the visual method.

Aural Sense Switch

- L: Left sense determination using aural Direction Finding
- R: Right sense determination using aural Direction Finding
- Central position: OFF

R1155 Radio Receiver Set

Meter Frequency Switch
Alters the switching frequency from 30 (LOW) to 80 (HIGH) cycles per second.

Meter Balance Control
Is in circuit when the Master Switch is in either the BALANCE or VISUAL position.

R1155 Radio Receiver Set Master Selector Switch

- **Omni (O):** All round reception.
- **A.V.C.:** Gives automatic volume control.
- **Balance.:** for Visual D/F (Direction Finding), for the purpose of matching the circuits and valves associated with the visual indicator.
- **Visual D/F.:** In this position, A.V.C. is in use.
- **Figure-of-Eight (∞):** Aural Direction Finding, bearings are taken on aural nulls, using the bandswitch for sense determination. The H/F gain is manually controlled, the A.V.C. being disconnected.

Volume Control

Heterodyne Switch

- UP: BFO OFF
- DOWN: BFO ON

Switches on or off the beat frequency oscillator (BFO)

R1155 Radio Receiver Set Frequency Range Switch

- **18/7.5:** Range from 18.5 MHz to 7.5 MHz (H/F)
- **7.5/3.0:** Range from 7.5 MHz to 3.0 MHz (H/F, used for Directional Finding)
- **1500/600:** Range from 1500 KHz to 600 KHz (M/F, used for Directional Finding)
- **500/200:** Range from 500 KHz to 200 KHz (M/F, used for Directional Finding)
- **200/75:** Range from 200 KHz to 75 KHz (M/F, used for Directional Finding)

4 – T1154 & R1155 RADIO SET

4.1 – T1154 TRANSMITTER & R1155 RECEIVER COMPONENTS

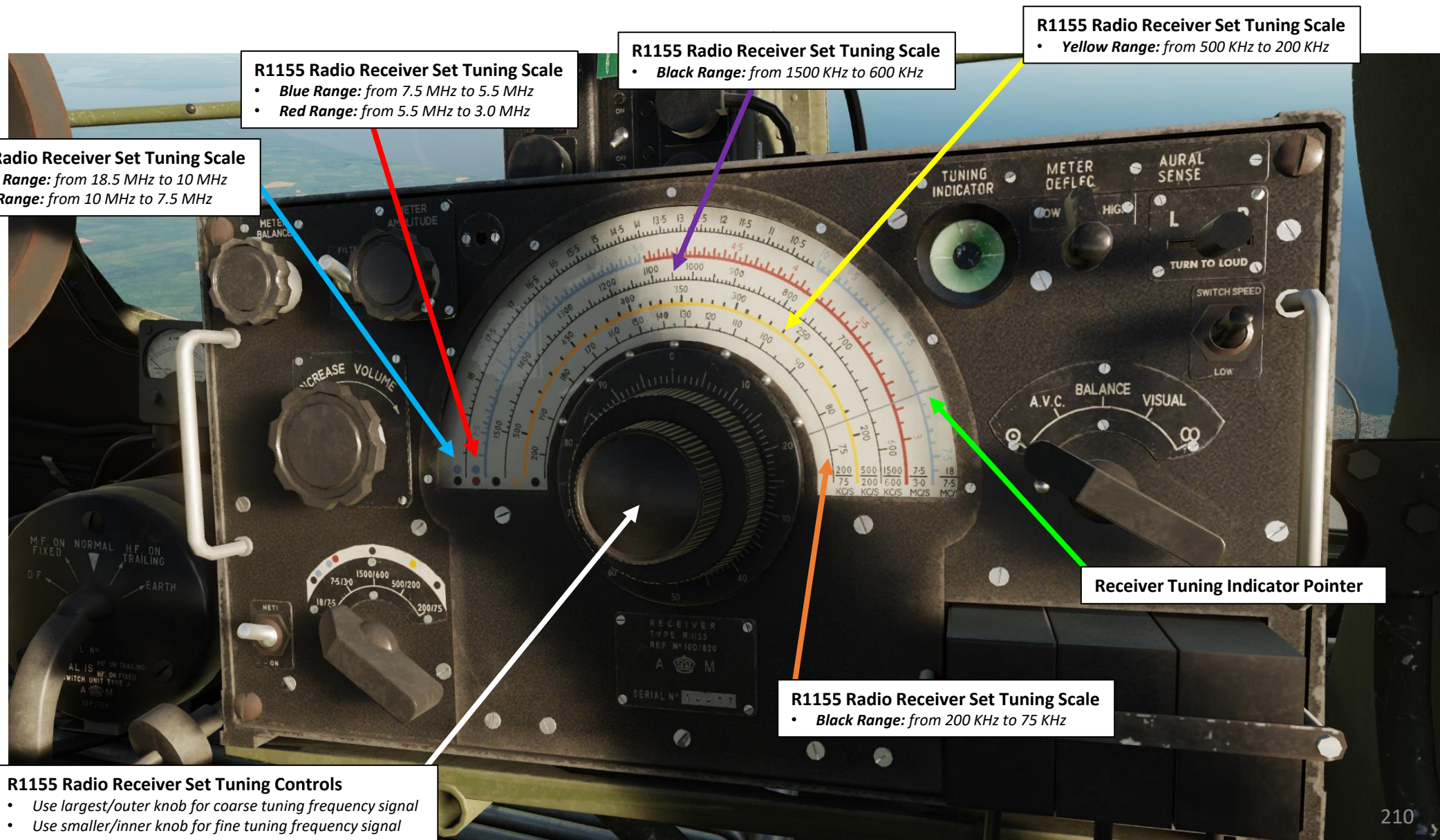

R1155 Radio Receiver Set Tuning Scale

- **Black Range:** from 18.5 MHz to 10 MHz
- **Blue Range:** from 10 MHz to 7.5 MHz

R1155 Radio Receiver Set Tuning Scale

- **Blue Range:** from 7.5 MHz to 5.5 MHz
- **Red Range:** from 5.5 MHz to 3.0 MHz

R1155 Radio Receiver Set Tuning Scale

- **Black Range:** from 1500 KHz to 600 KHz

R1155 Radio Receiver Set Tuning Scale

- **Yellow Range:** from 500 KHz to 200 KHz

Receiver Tuning Indicator Pointer

R1155 Radio Receiver Set Tuning Scale

- **Black Range:** from 200 KHz to 75 KHz

R1155 Radio Receiver Set Tuning Controls

- Use largest/outer knob for coarse tuning frequency signal
- Use smaller/inner knob for fine tuning frequency signal

4 – T1154 & R1155 RADIO SET

4.1 – T1154 TRANSMITTER & R1155 RECEIVER COMPONENTS

Receiver Tuning Indicator Light (“Magic Eye”)

A magic eye tube is an electronic vacuum tube that provides visual indication, usually in the form of green light, on an area called the target inside the tube. The target is partially illuminated with the exception of the shadow area, which varies in size and shape depending on the signal applied to the tube. The phrase "magic eye" became a trade-mark of Radio Corporation of America in the mid 1930s, who introduced the tube as a visual tuning aid for radio receivers. Other names for the magic eye tube included "tuning eye" and "cat's eye" as well as its technical name, cathode ray indicator. Occasionally, skeptics or pundits would call it an "idiot lamp".

The first broad application of the magic eye was as a tuning indicator in radio receivers, to give an indication of the relative strength of the received radio signal, to show when a radio station was properly tuned in.

Reference: <http://www.magicvetubes.com/>

Large Shadow Area Weak Signal

Scenario 1: Radio is turned on, but a very weak signal on the reception frequency is received.

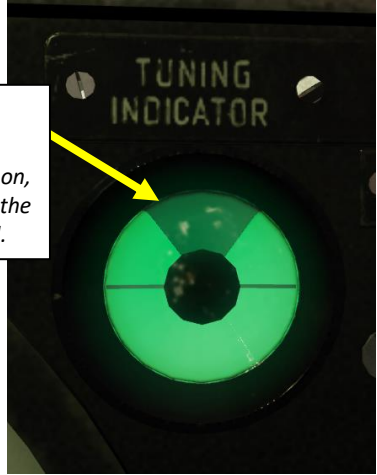

Smaller Shadow Area Strong Signal

Scenario 2: Radio is turned on, and a strong signal on the reception frequency is received.

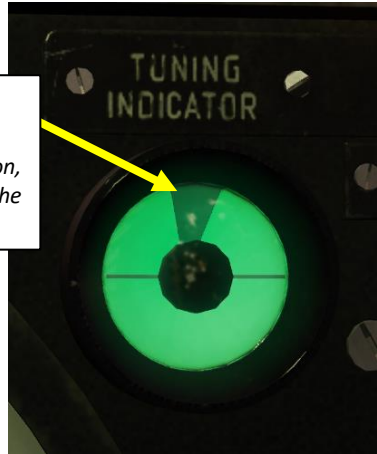

Radio is OFF

Scenario 3: Radio is turned off. Magic Eye is extinguished.

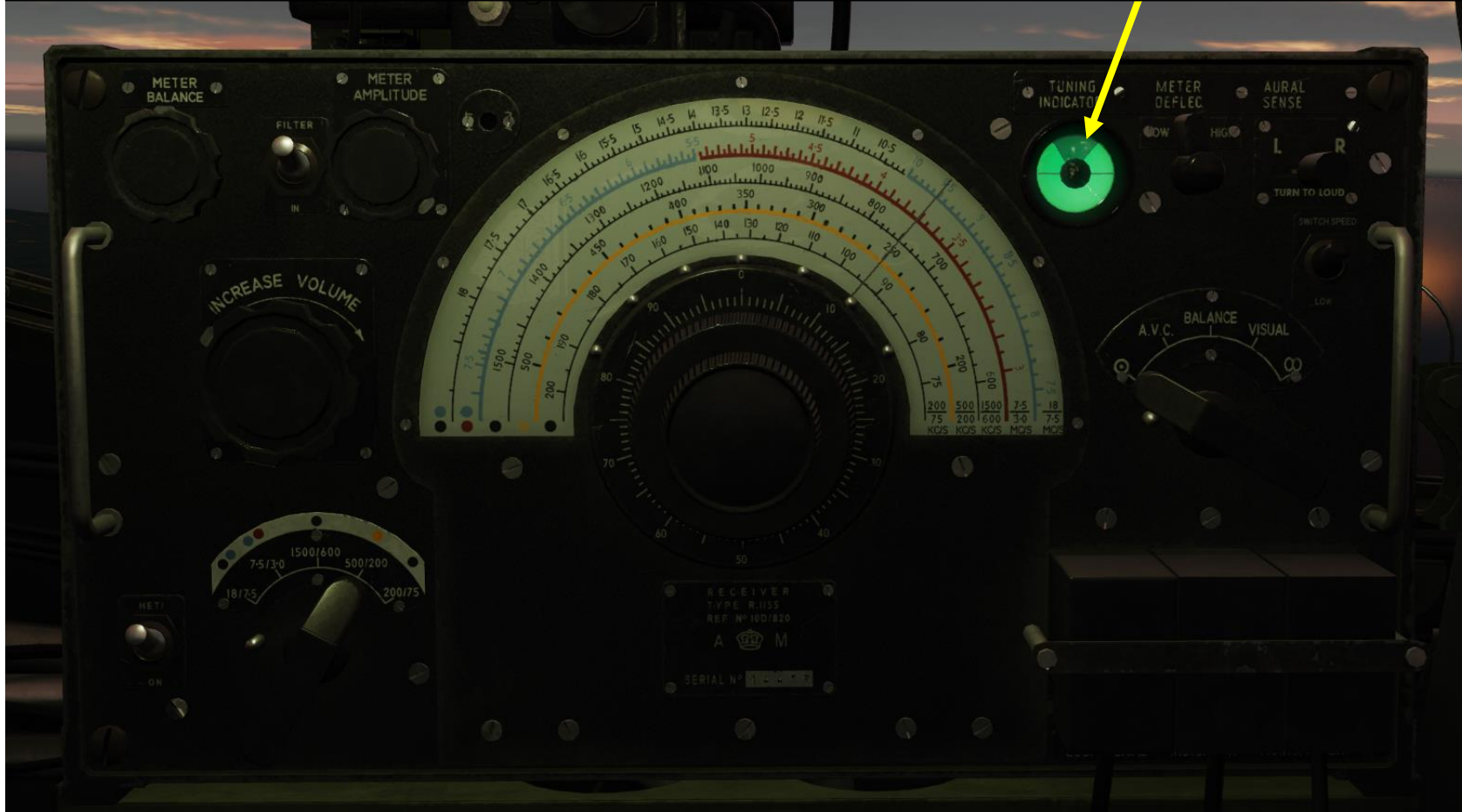
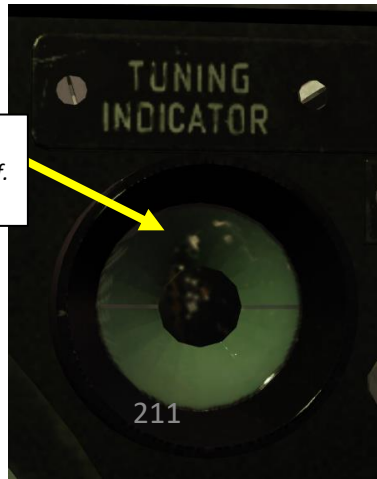

4 – T1154 & R1155 RADIO SET

4.1 – T1154 TRANSMITTER & R1155 RECEIVER COMPONENTS

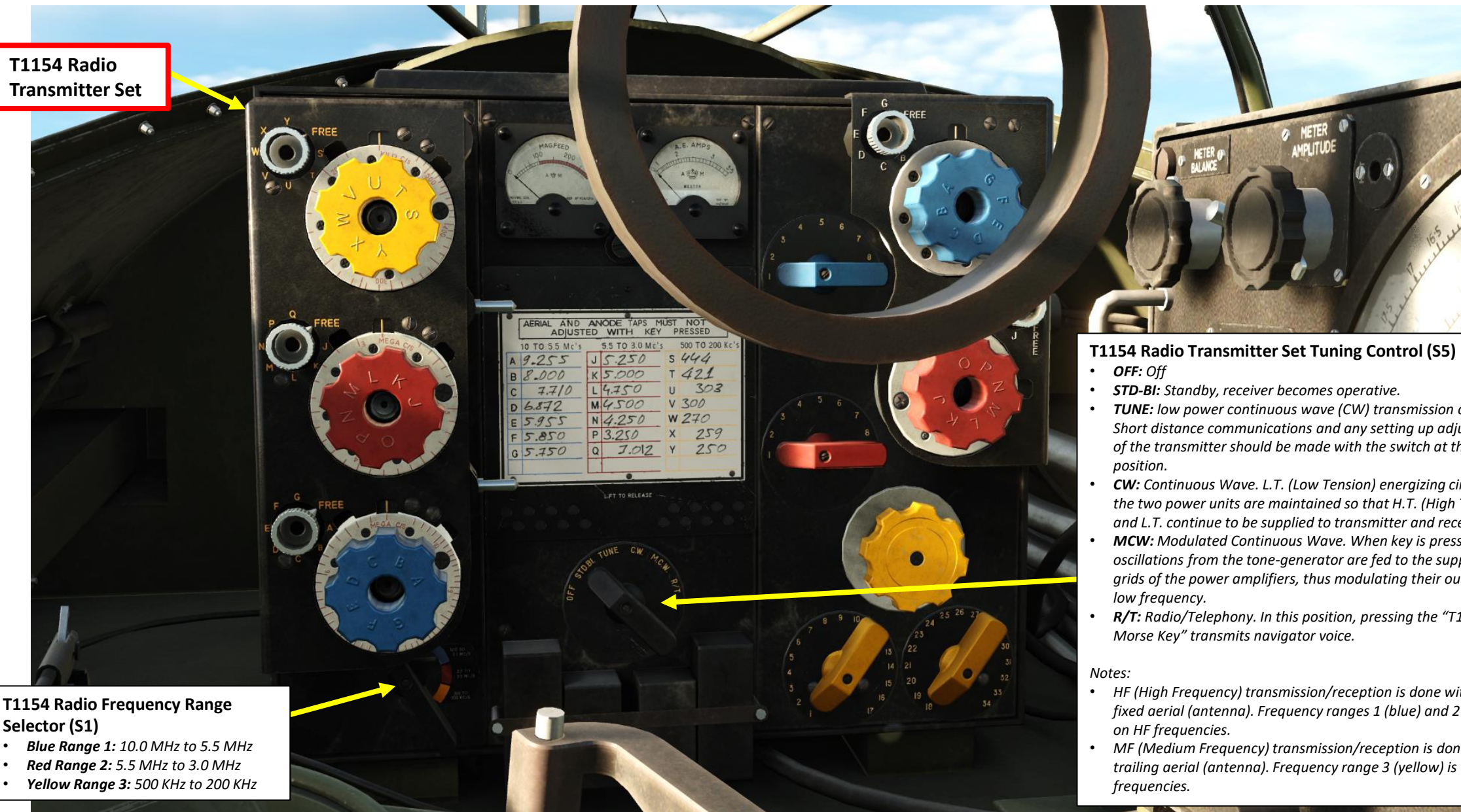

T1154 Radio
Transmitter Set

T1154 Radio Frequency Range
Selector (S1)

- **Blue Range 1:** 10.0 MHz to 5.5 MHz
- **Red Range 2:** 5.5 MHz to 3.0 MHz
- **Yellow Range 3:** 500 KHz to 200 KHz

AERIAL AND ANODE TAPS MUST NOT
ADJUSTED WITH KEY PRESSED

10 TO 5.5 Mc's		5.5 TO 3.0 Mc's		500 TO 200 Kc's	
A	9.255	J	5.250	S	444
B	8.000	K	5.000	T	421
C	7.710	L	4.750	U	303
D	6.872	M	4.500	V	300
E	5.955	N	4.250	W	270
F	5.850	P	3.250	X	259
G	5.750	Q	3.012	Y	250

T1154 Radio Transmitter Set Tuning Control (S5)

- **OFF:** Off
- **STD-BI:** Standby, receiver becomes operative.
- **TUNE:** low power continuous wave (CW) transmission occurs. Short distance communications and any setting up adjustments of the transmitter should be made with the switch at this position.
- **CW:** Continuous Wave. L.T. (Low Tension) energizing circuits of the two power units are maintained so that H.T. (High Tension) and L.T. continue to be supplied to transmitter and receiver.
- **MCW:** Modulated Continuous Wave. When key is pressed, oscillations from the tone-generator are fed to the suppressor grids of the power amplifiers, thus modulating their output at low frequency.
- **R/T:** Radio/Telephony. In this position, pressing the "T1154 Radio Morse Key" transmits navigator voice.

Notes:

- HF (High Frequency) transmission/reception is done with the fixed aerial (antenna). Frequency ranges 1 (blue) and 2 (red) are on HF frequencies.
- MF (Medium Frequency) transmission/reception is done with the trailing aerial (antenna). Frequency range 3 (yellow) is on MF frequencies.

4 – T1154 & R1155 RADIO SET

4.1 – T1154 TRANSMITTER & R1155 RECEIVER COMPONENTS

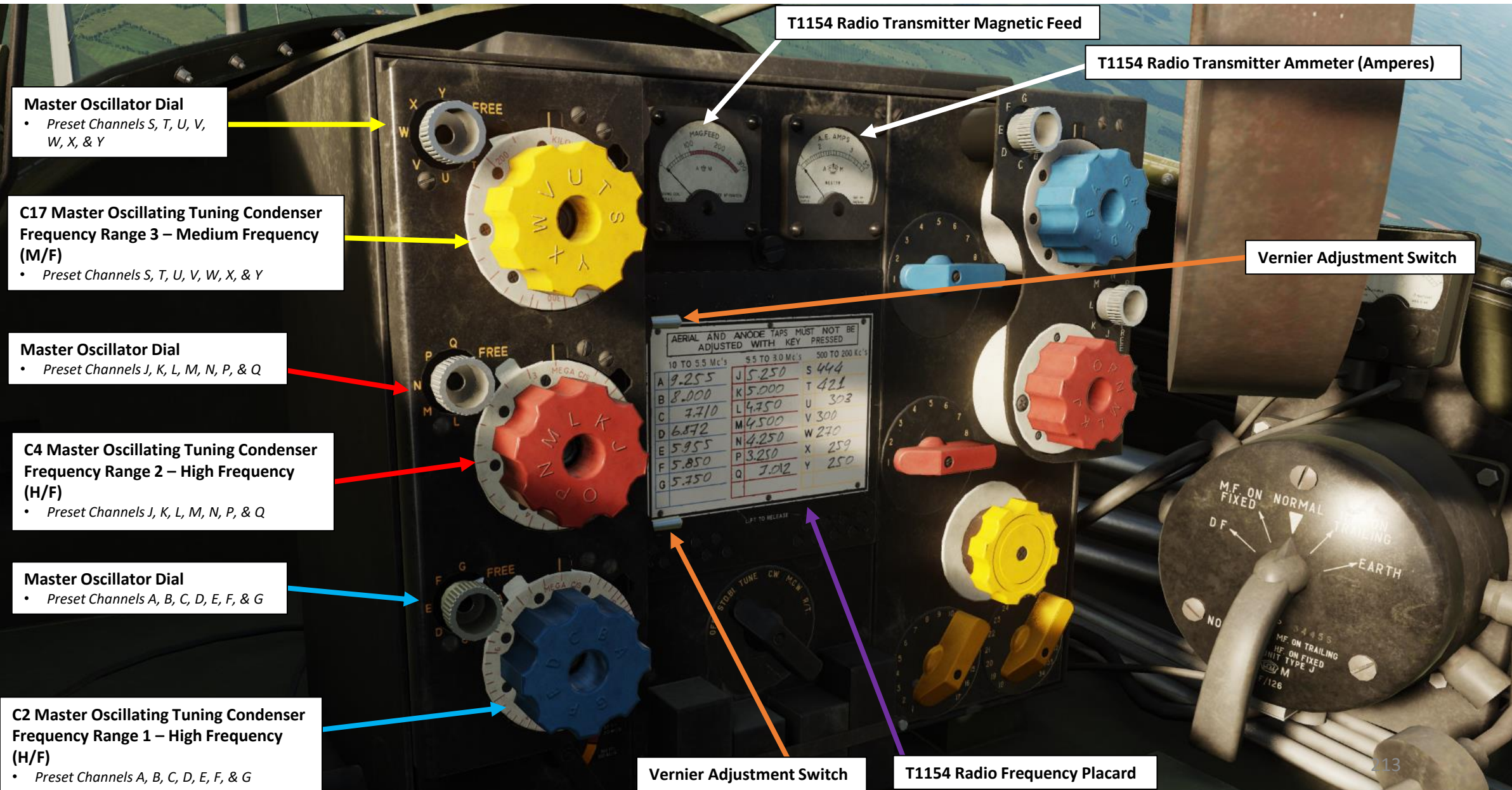

4 – T1154 & R1155 RADIO SET

4.1 – T1154 TRANSMITTER & R1155 RECEIVER COMPONENTS

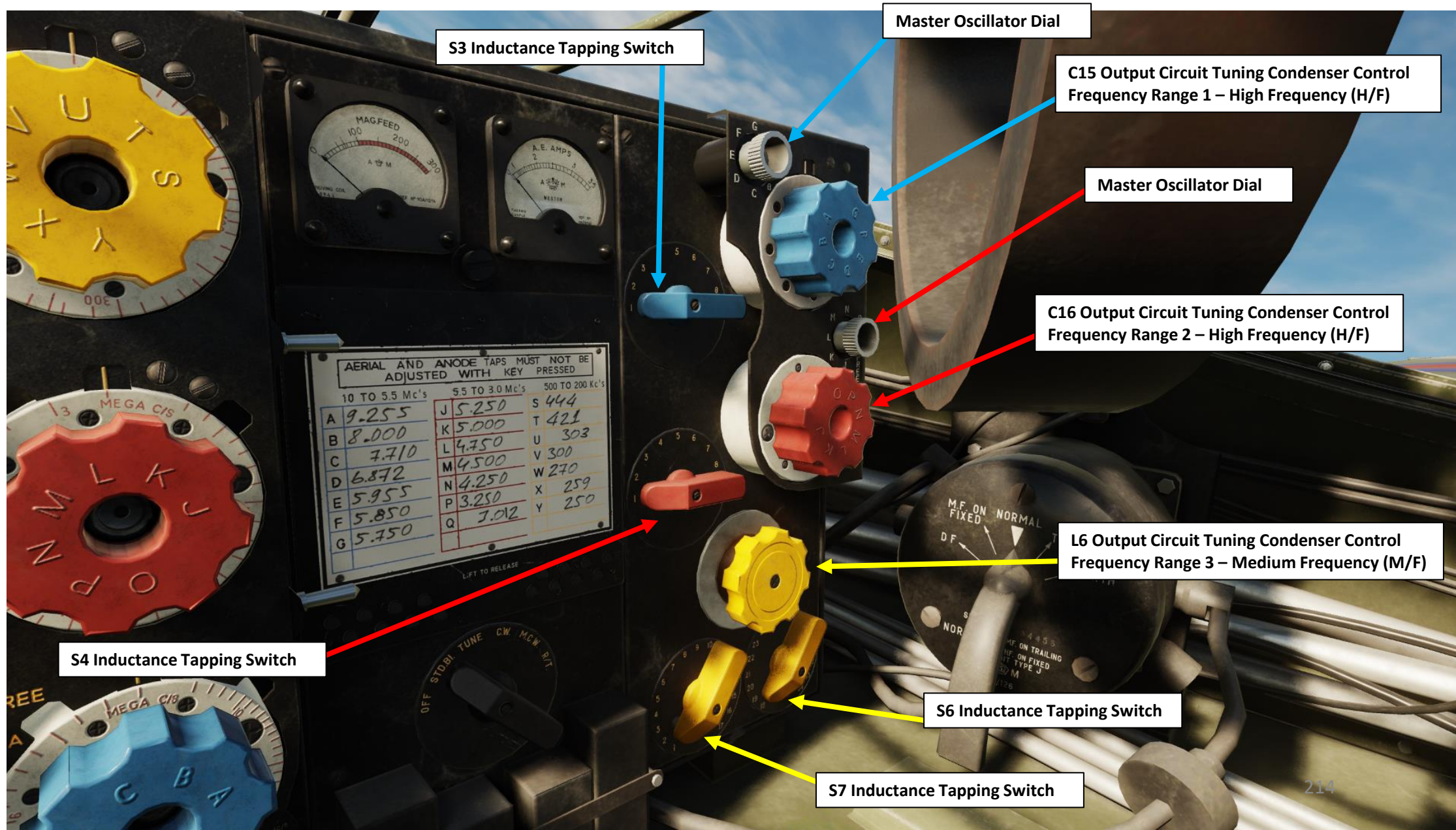

4 – T1154 & R1155 RADIO SET

4.1 – T1154 TRANSMITTER & R1155 RECEIVER COMPONENTS

The **Inductance Tapping controls** are used to connect the aerial (antenna) to any of the output circuit inductances.

See this video for more information: <https://youtu.be/KSylo01n5FY>

The **Condenser controls** (also known as “variable capacitors”) are used to adjust radio transmitter frequencies. The oscillator frequency is also tuned when its associated condenser is being tuned.

See this video for more information: <https://youtu.be/adTdkM7Brs>

The **Oscillator controls** are used to stabilize radiated frequency of the condenser/capacitor.

See this video for more information: <https://youtu.be/yCwKB0Wvi-o>

The **Vernier controls** are used for frequency adjustment of +/- 1%.

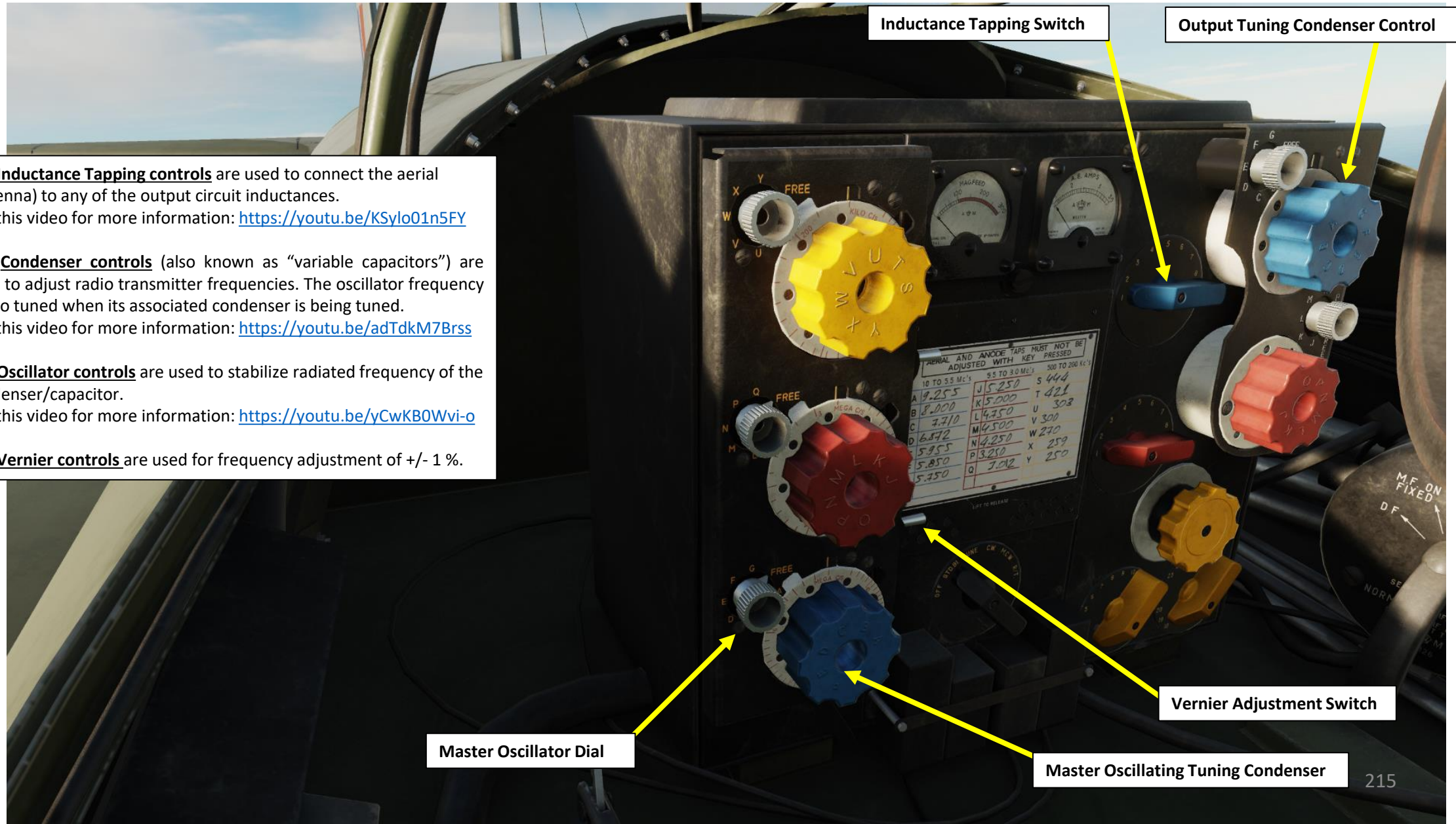

Master Oscillator Dial

Master Oscillating Tuning Condenser

4 – T1154 & R1155 RADIO SET

4.1 – T1154 TRANSMITTER & R1155 RECEIVER COMPONENTS

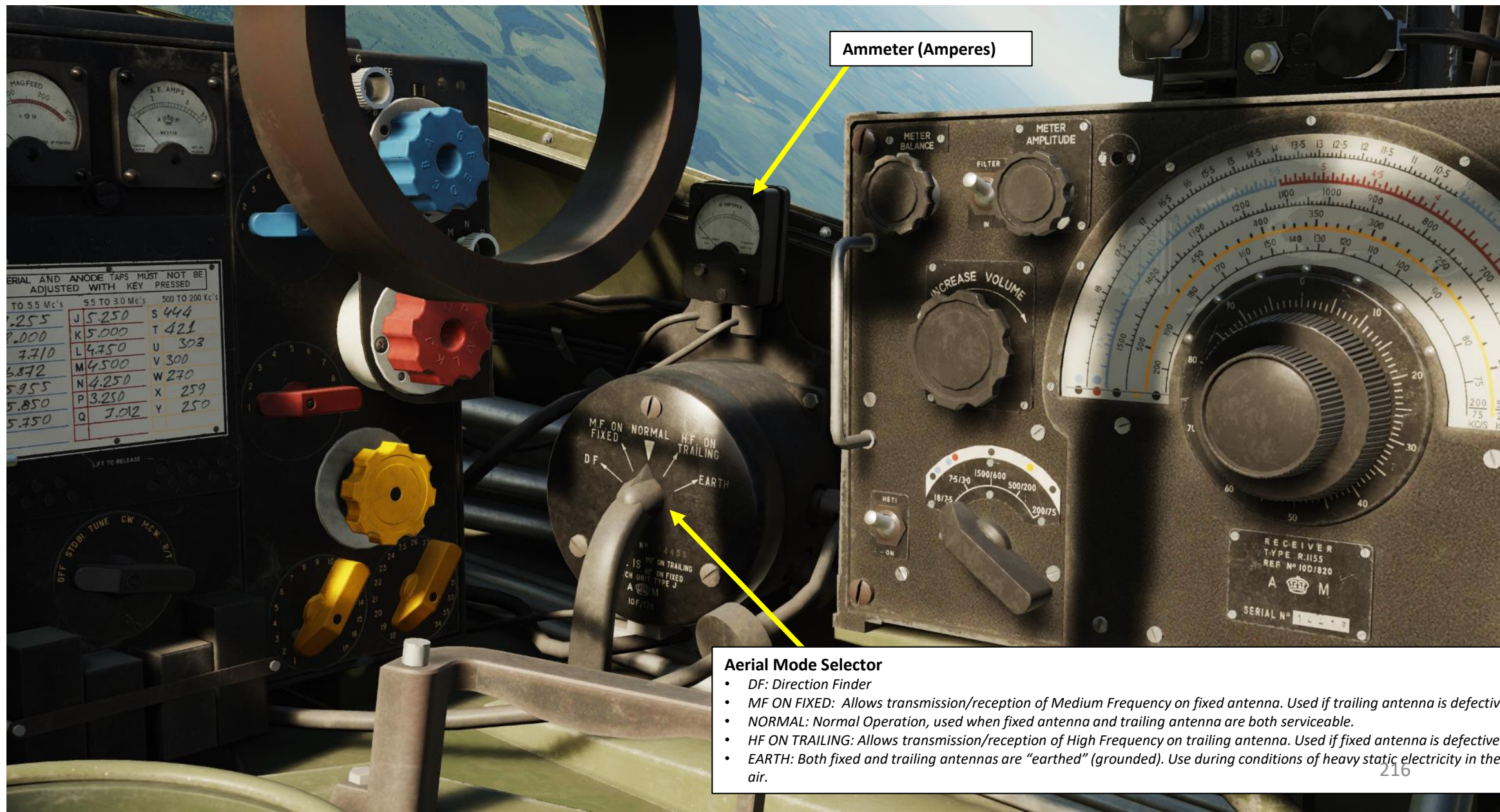

Ammeter (Amperes)

Aerial Mode Selector

- *DF*: Direction Finder
- *MF ON FIXED*: Allows transmission/reception of Medium Frequency on fixed antenna. Used if trailing antenna is defective.
- *NORMAL*: Normal Operation, used when fixed antenna and trailing antenna are both serviceable.
- *HF ON TRAILING*: Allows transmission/reception of High Frequency on trailing antenna. Used if fixed antenna is defective.
- *EARTH*: Both fixed and trailing antennas are “earthed” (grounded). Use during conditions of heavy static electricity in the air.

4 – T1154 & R1155 RADIO SET

4.1 – T1154 TRANSMITTER & R1155 RECEIVER COMPONENTS

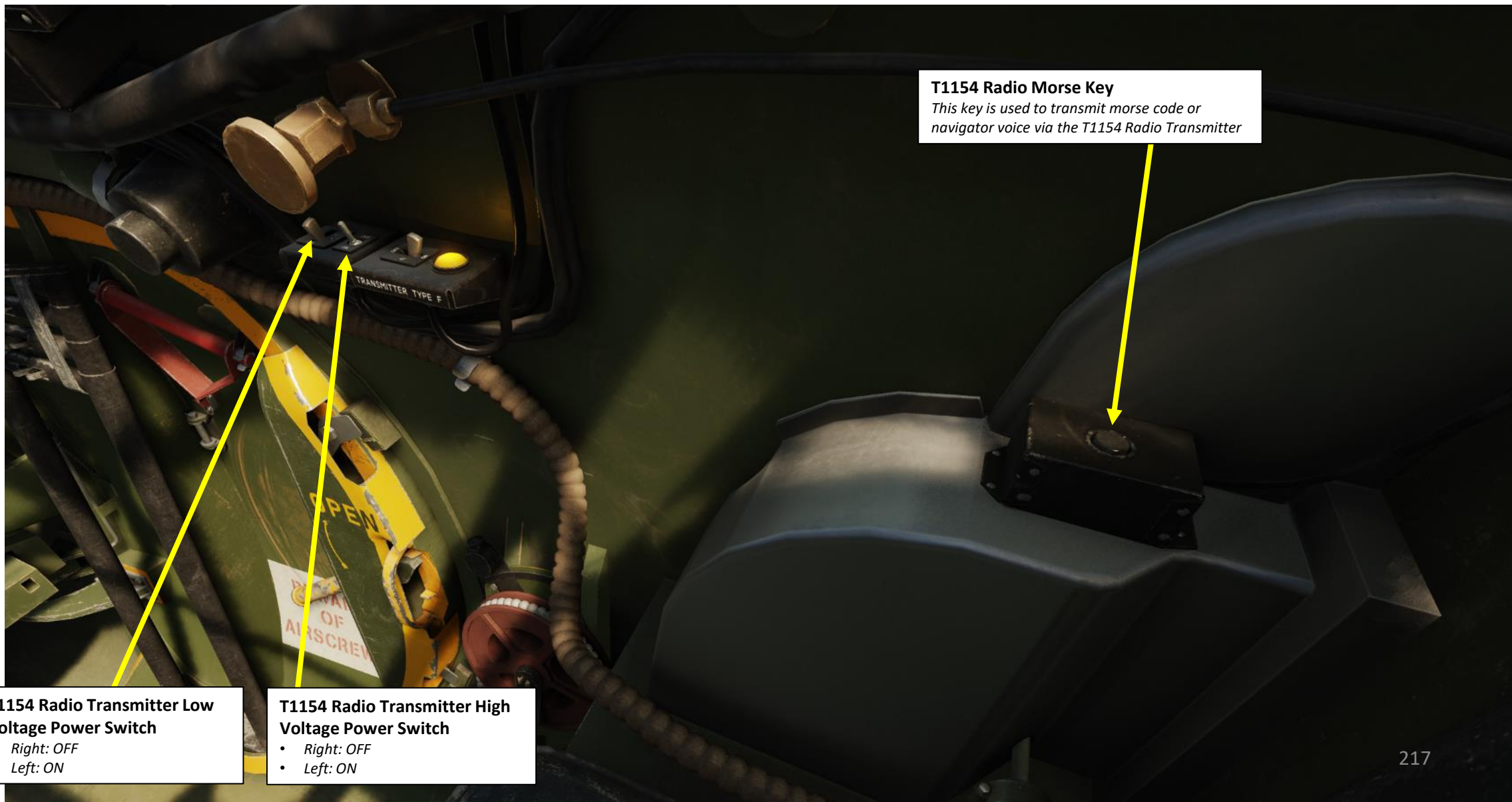

T1154 Radio Morse Key
This key is used to transmit morse code or navigator voice via the T1154 Radio Transmitter

T1154 Radio Transmitter Low Voltage Power Switch
• Right: OFF
• Left: ON

T1154 Radio Transmitter High Voltage Power Switch
• Right: OFF
• Left: ON

4 – T1154 & R1155 RADIO SET

4.1 – T1154 TRANSMITTER & R1155 RECEIVER COMPONENTS

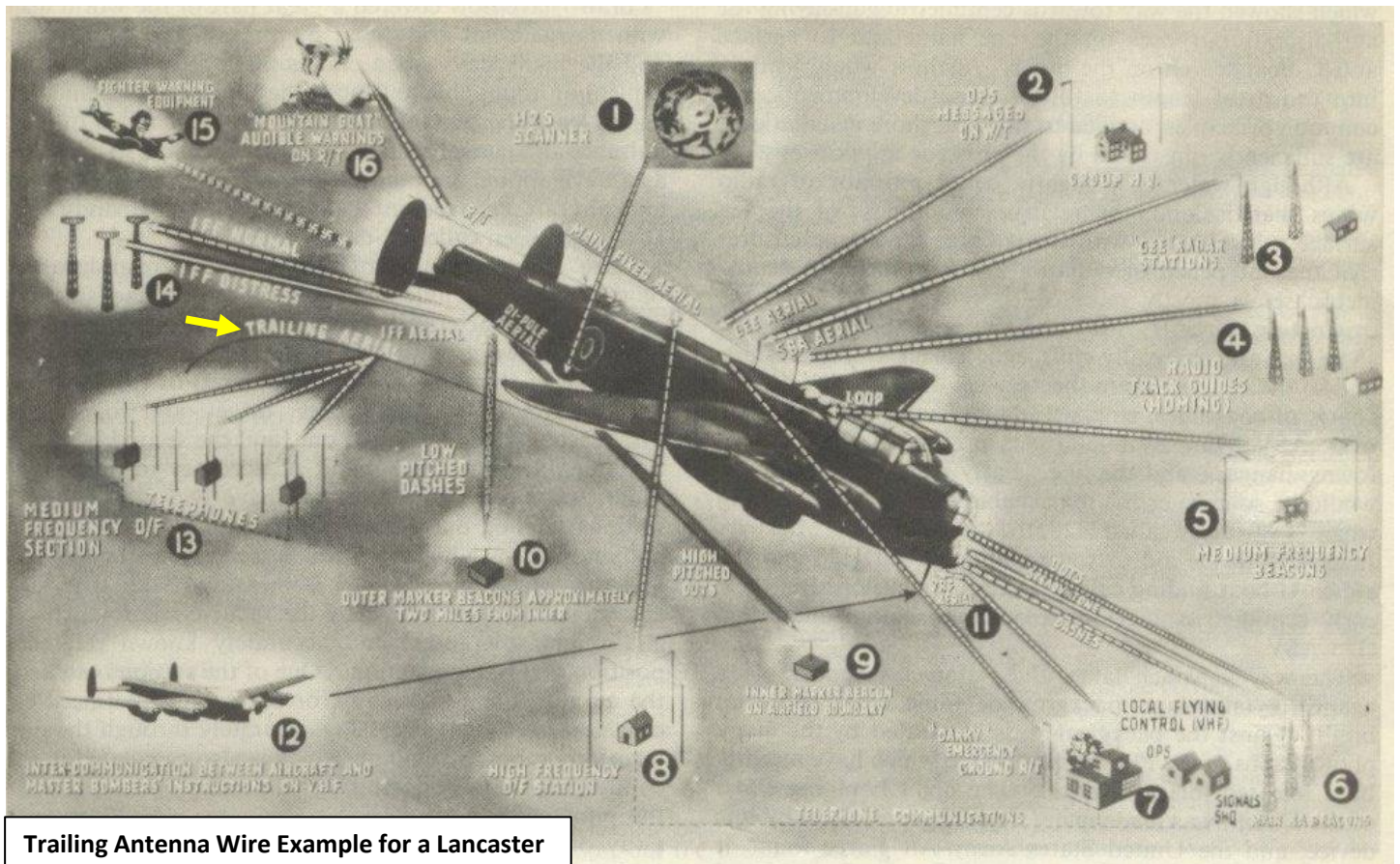

Trailing Antenna Wire Example for a Lancaster

MF Trailing Antenna Wire
In certain variants of the Mosquito, in order to communicate on MF (medium frequencies), a long "trailing" antenna had to be reeled out of the plane. The antenna would have to be reeled back in in order to avoid having the wire tangled up in trees or electrical power lines.

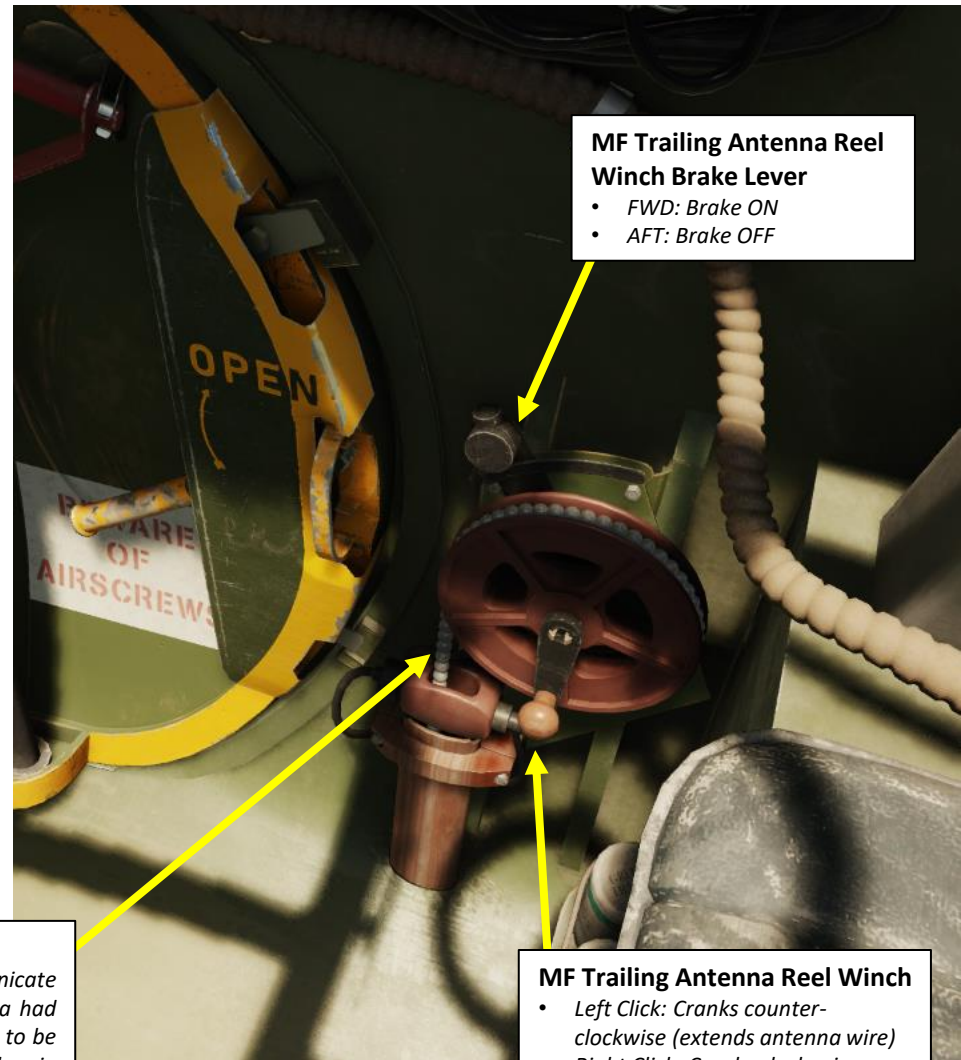

MF Trailing Antenna Reel Winch Brake Lever

- FWD: Brake ON
- AFT: Brake OFF

MF Trailing Antenna Reel Winch

- Left Click: Cranks counter-clockwise (extends antenna wire)
- Right Click: Cranks clock-wise (retracts antenna wire)

4 – T1154 & R1155 RADIO SET

4.2 – TRANSMISSION & RECEPTION TUTORIAL (HF)

In this tutorial, we will communicate with the **Manston Control Tower**, which is set to a **HF (High Frequency) range of 3.975 MHz** (or MegaCycles/Second). We will need to set both the T1154 Transmitter to transmit our request to the tower and the R1155 Receiver to receive the tower's response. You can have preset frequencies for three frequency ranges, but these frequencies are set via the Mission Editor. It is possible to manually adjust a frequency, but it isn't necessarily recommended due to the difficulty to be precise.

Since we cover a frequency in the second frequency range (red range), we will use the fixed antenna. The T1154/R1155 radio can cover three sets of frequency ranges:

- **Blue Range 1 (HF, with Fixed Antenna):** 10.0 MHz to 5.5 MHz
- **Red Range 2 (HF, with Fixed Antenna):** 5.5 MHz to 3.0 MHz
- **Yellow Range 3 (MF, with Trailing Antenna):** 500 KHz to 200 KHz

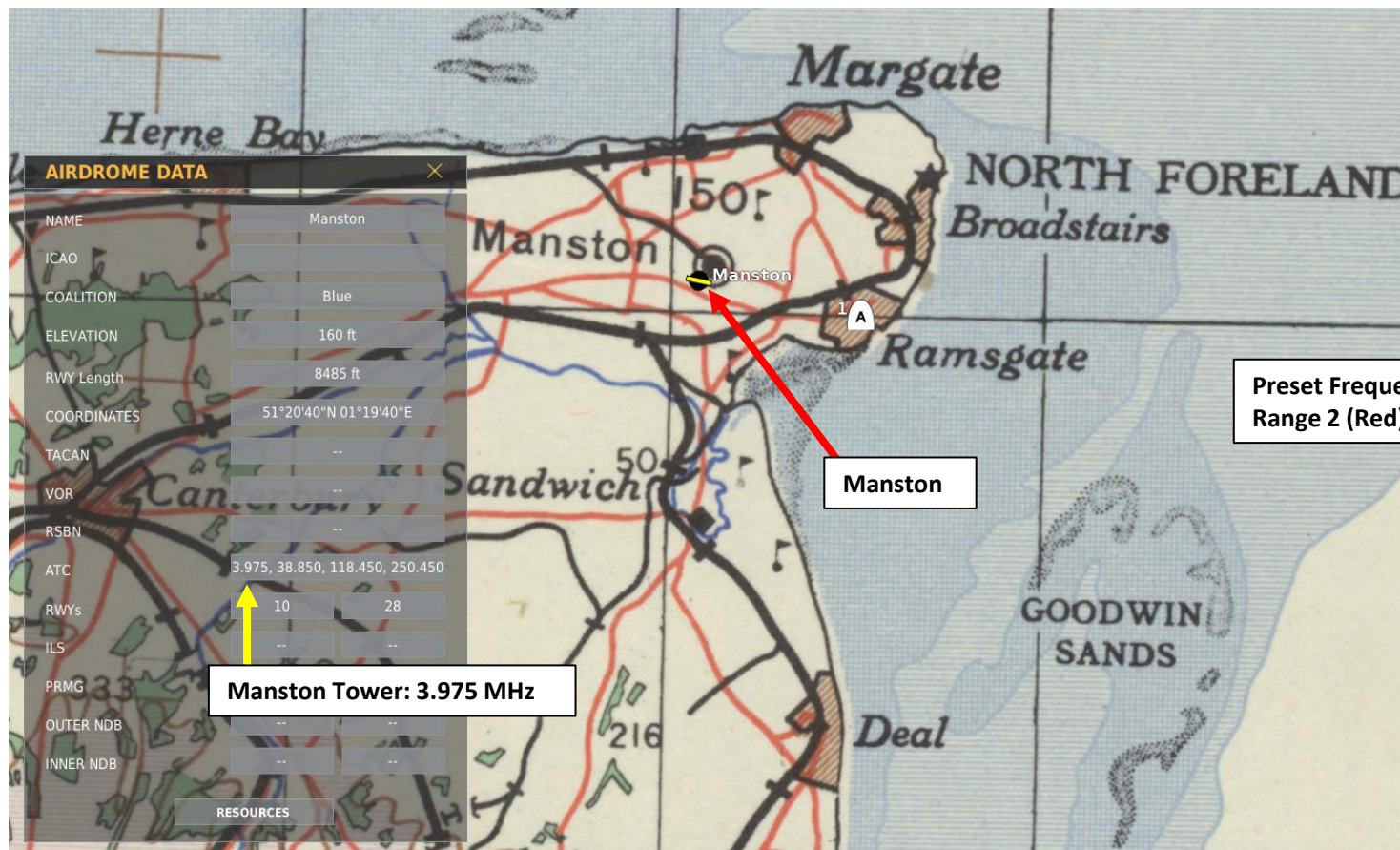

Preset Frequency "P"
Range 2 (Red) 3.975 MHz

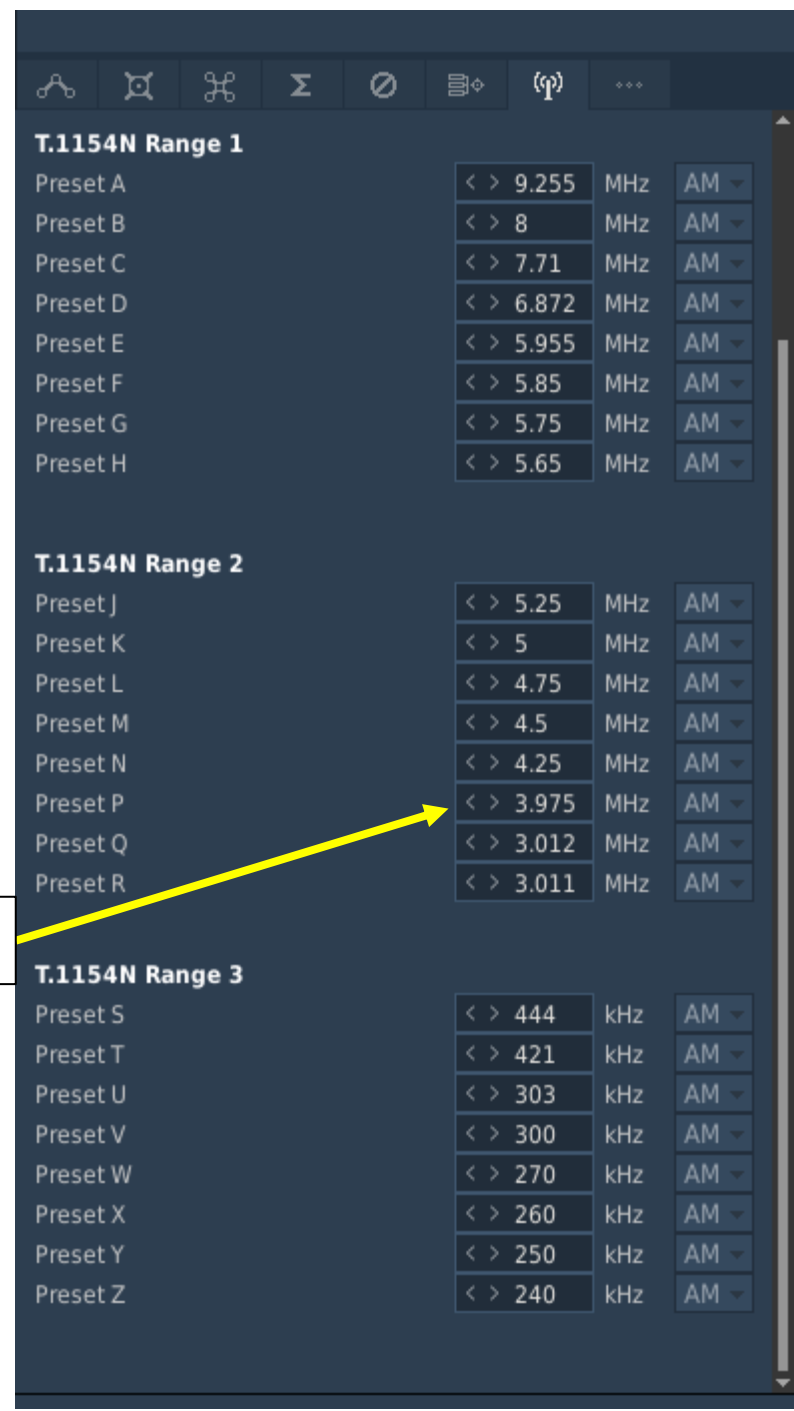

4 – T1154 & R1155 RADIO SET

4.2 – TRANSMISSION & RECEPTION TUTORIAL (HF)

1. Select the Navigator Seat by pressing “2”.
2. Set T1154 Radio Transmitter Low Voltage Power Switch – ON (LEFT)
3. Set T1154 Radio Transmitter High Voltage Power Switch – ON (LEFT)
4. Lower the armored headrest of the navigator seat to access the radio compartment by clicking on the headrest handle.
5. In low visibility conditions, I would advise you to turn on the Dome Light and use the flashlight (LALT+L).

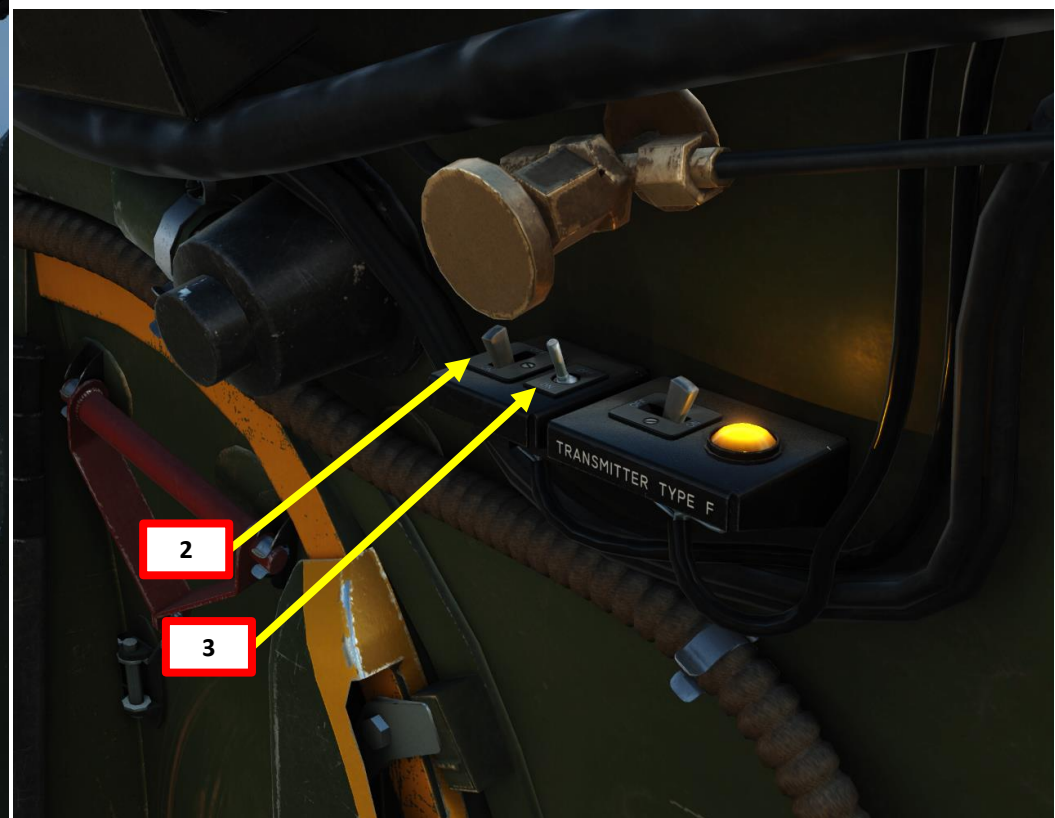
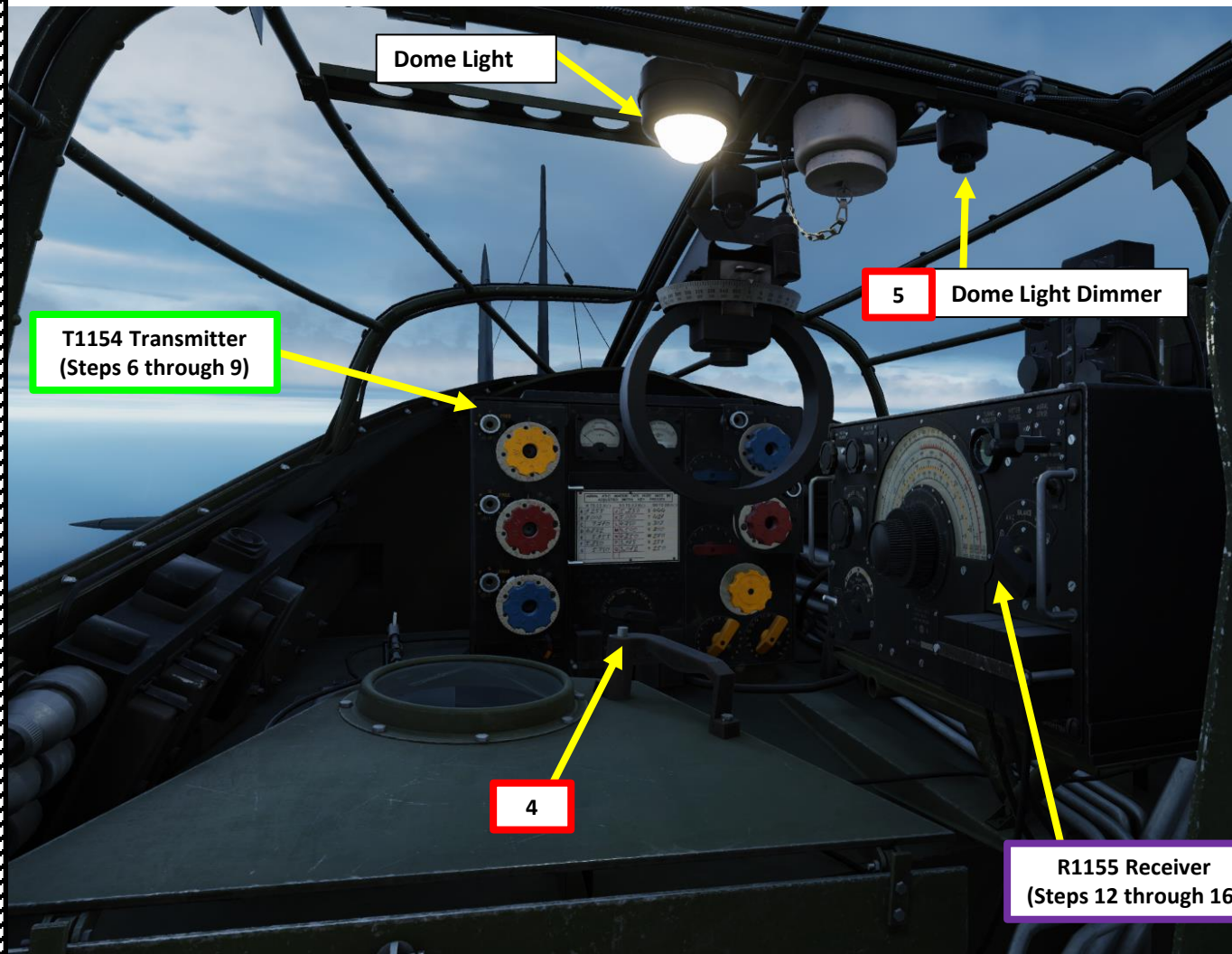

4 – T1154 & R1155 RADIO SET

4.2 – TRANSMISSION & RECEPTION TUTORIAL (HF)

6. Set T1154 Radio Transmitter Set Tuning Control knob to STD-BI (Standby) position, then to TUNE position.
7. Set T1154 Radio Frequency Range Selector to the required frequency range. We want to transmit on Preset Channel "P", which is in the No. 2 Range (Red). Check the placard on the T1154 set to see which preset channel is in which range according to its color code.
8. To select Preset Frequency "P" (Frequency Range 2, Red):
 - a) Set Range 2 Master Oscillator Dial to "P".
 - b) Turn Range 2 Master Oscillating Tuning Condenser until it "clicks" (click-stop mechanism) when reaching the preset position near 3.975 MHz.
 - When the condenser "clicks", it becomes locked into position and can only be moved if the associated Master Oscillator Dial is reset to "FREE".
 - c) Use Vernier Adjustment Switch for fine tuning if required.
 - d) Turn Range 2 Output Master Oscillator Dial to "P"
 - e) Turn Range 2 Output Circuit Tuning Condenser Control until it "clicks" (click-stop mechanism) when reaching the preset position near 3.975 MHz. See note for step b), which is applicable here as well.
 - f) If required, adjust Range 2 Inductance Tapping (not simulated).

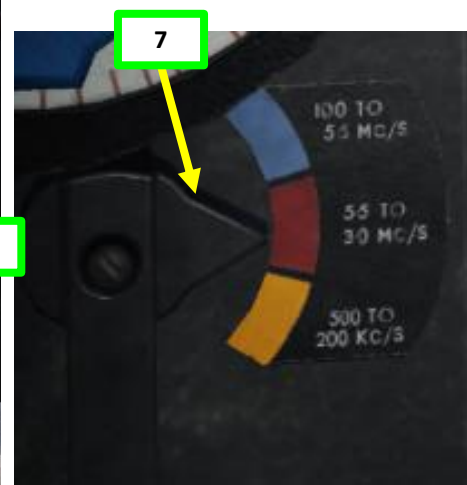
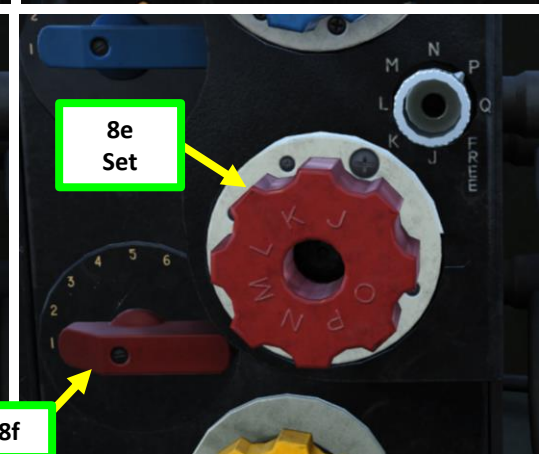
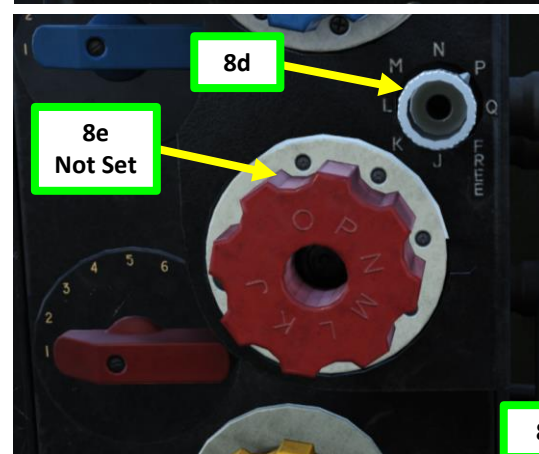
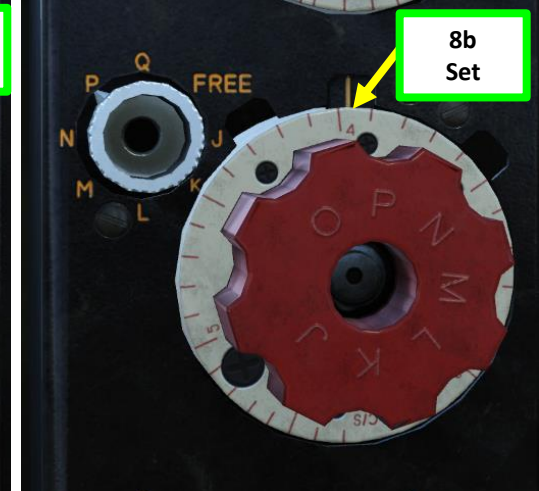
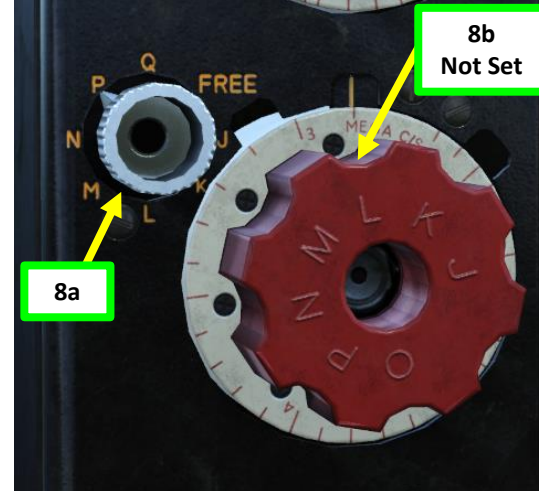
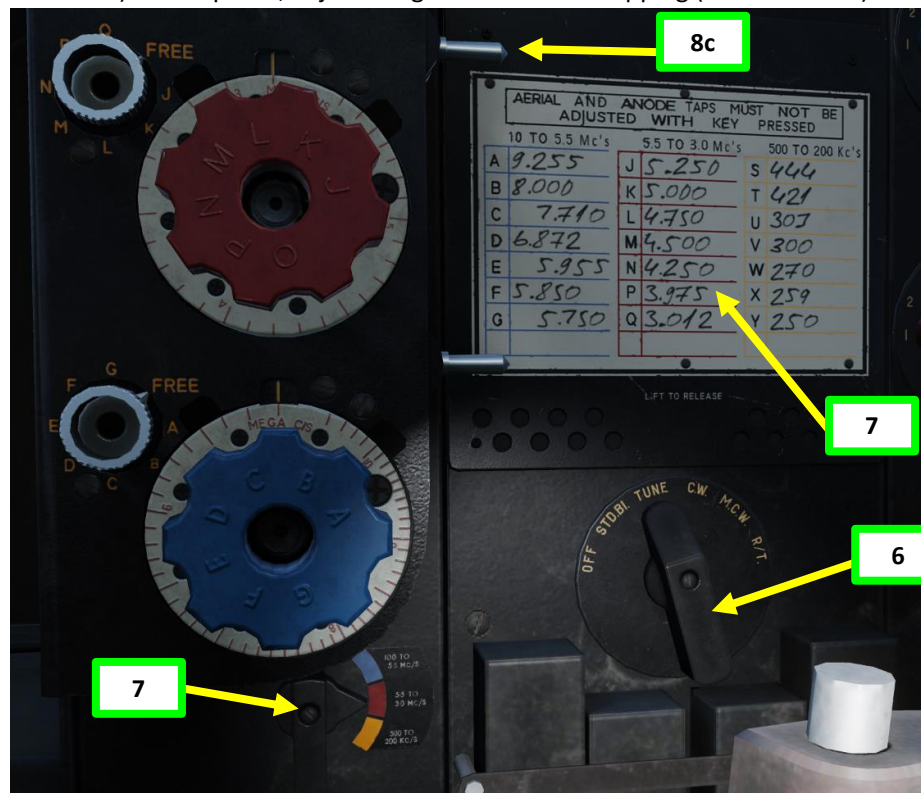

Note: If you want to tune the transmitter manually without using one of the preset frequencies, you can set the Master Oscillator for the condensers to "Free". This will unlock the condenser control and allow you to set it at any position you want. This step would only apply to steps 8 a) and 8 d).

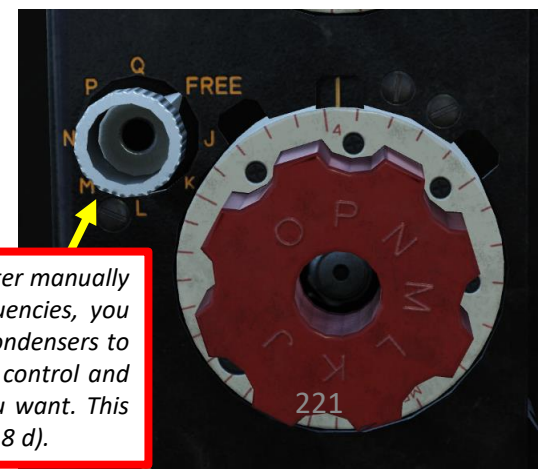

4 – T1154 & R1155 RADIO SET

4.2 – TRANSMISSION & RECEPTION TUTORIAL (HF)

9. Now that we have set the transmitter frequency, set T1154 Radio Transmitter Set Tuning Control knob to R/T (Radio/Telephony). This will allow you to transmit voice signals.
10. Since we transmit and receive on a HF frequency, we can use the Fixed Antenna.
11. Set Aerial (Antenna) Mode Selector – NORMAL

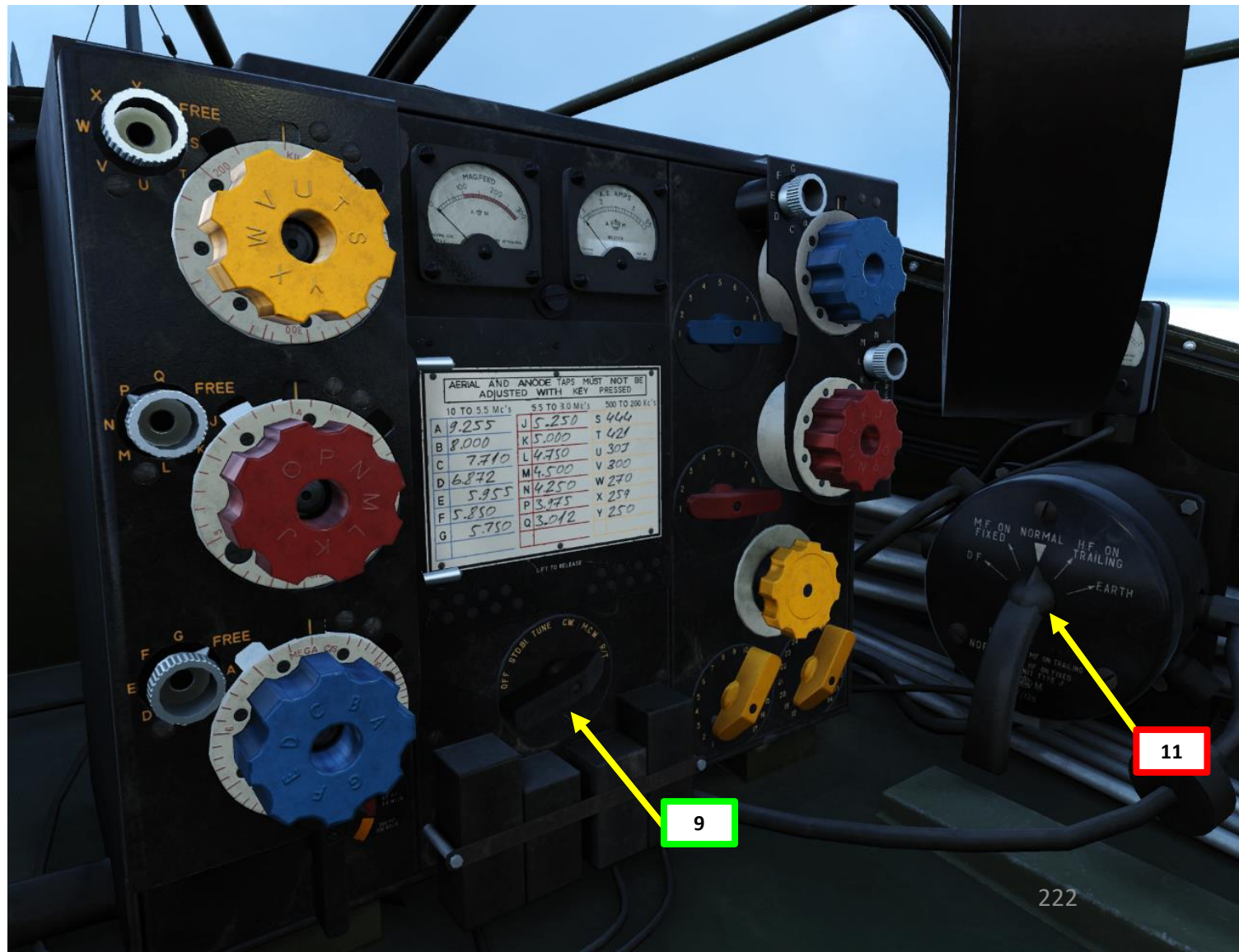

4 – T1154 & R1155 RADIO SET

4.2 – TRANSMISSION & RECEPTION TUTORIAL (HF)

12. Set R1155 Radio Receiver Set Master Selector Switch – Omni (O)
13. Confirm that the Tuning Indicator Light illuminates
14. Set the R1155 Radio Receiver Set Frequency Range Switch to the appropriate frequency range (“7.5/3.0” for frequency 3.975 MHz).
15. Use tuning knobs to set radio frequency needle to the appropriate frequency (3.975 MHz). Since we use the 7.5/3.0 frequency range, we use the fourth band from the bottom (in red).
 - Use the outer tuning knob for coarse tuning (big needle movements) and the inner tuning knob for fine tuning (small needle movements).
16. Adjust Volume Control.

Note:
 “Back Tuning” is not simulated yet. “Back tuning” is basically the process of setting the receiver frequency first, and then tune the transmitter to match the receiver frequency. This ensures both the transmitter and the receiver have matching frequencies.

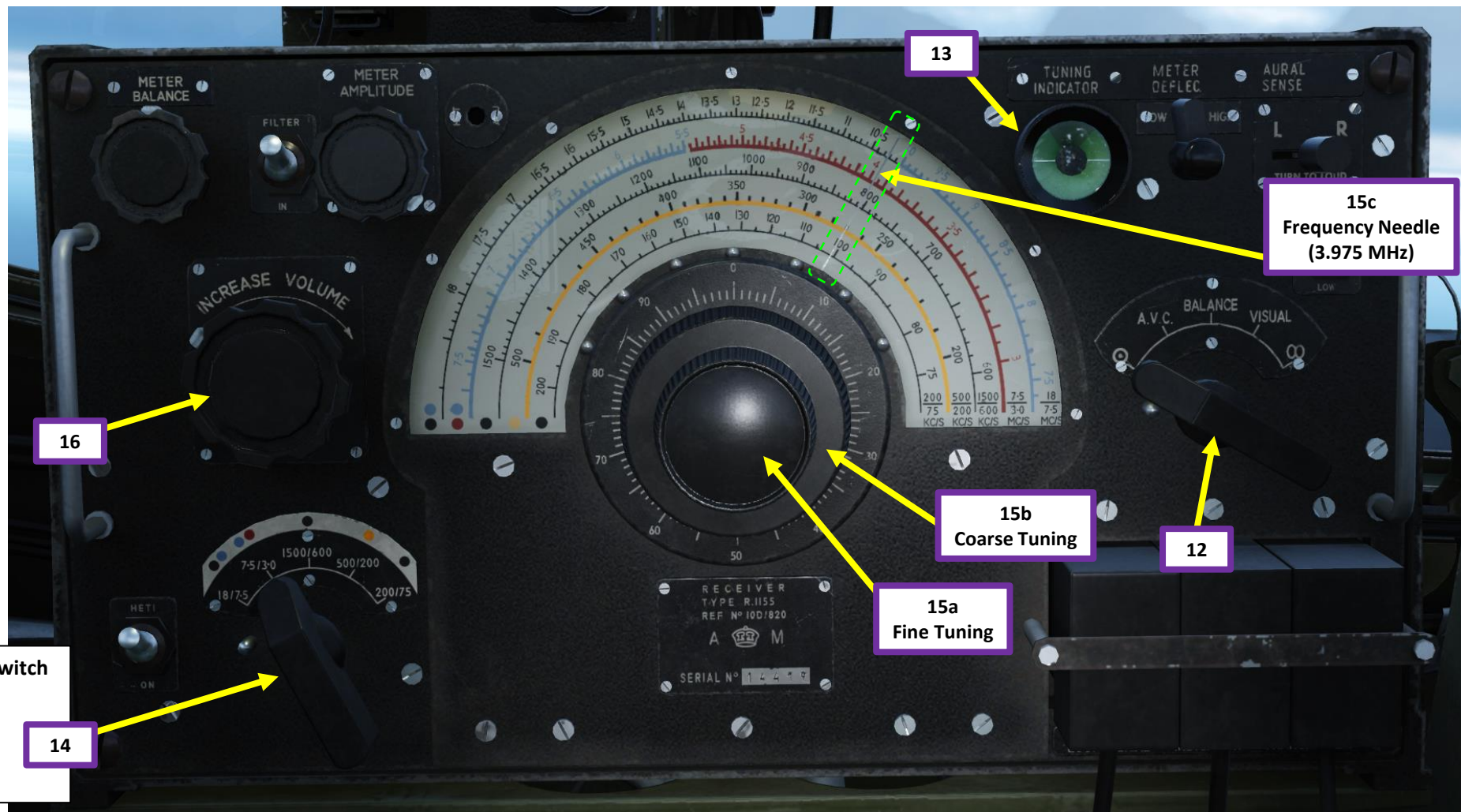

R1155 Radio Receiver Set Frequency Range Switch

- 18/7.5: Range from 18.5 MHz to 7.5 MHz (H/F)
- 7.5/3.0: Range from 7.5 MHz to 3.0 MHz (H/F)
- 1500/600: Range from 1500 KHz to 600 KHz (M/F)
- 500/200: Range from 500 KHz to 200 KHz (M/F)
- 200/75: Range from 200 KHz to 75 KHz (M/F)

RECEIVER
 TYPE R.1155
 REF N° 10D/820
 A M
 SERIAL N° 1 4 4 9

4 – T1154 & R1155 RADIO SET

4.2 – TRANSMISSION & RECEPTION TUTORIAL (HF)

- Now that we have set both the T1154 Transmitter and the R1155 Receiver, we can communicate with the tower.
- Press the T1154 Radio Morse Key to transmit on the set frequency. The default binding is "LALT + \".

CONTROL OPTIONS

Mosquito FB Mk. VI !

All

Foldable view

Reset category to default

Clear category

Action

Category

Keyboard

Throttle - HOTA

T1154, key button - press

T.1154/R.1155 Radio Set,

LAlt + \

JOY_BTN26

Main

- F1. Wingman...
- F2. Flight...
- F3. Second Element...
- F5. ATC... ←
- F8. Ground Crew...
- F12. Exit

2. Main. ATC

- F1. Manston... ←
- F2. Hawkinge...
- F3. Lympne...
- F4. Eastchurch...
- F5. Headcorn...
- F6. High Halden...
- F7. Detling...
- F8. Dunkirk Mardyck...
- F9. Saint Omer Longuenesse...
- F10. Biggin Hill...
- F11. Previous Menu
- F12. Exit

3. Main. ATC. Manston

- F1. Inbound
- F2. Request Azimuth ←
- F11. Previous Menu
- F12. Exit

PLAYER: Manston, Enfield 1-1, request navigation assistance

ATC (Manston): Enfield 1-1, Manston-ADF, your heading 282



4 – T1154 & R1155 RADIO SET

4.3 – TRANSMISSION & RECEPTION TUTORIAL (MF)

In this tutorial, we will communicate with a **Ship**, which is set to a **MF (Medium Frequency) range of 303 KHz** (or KiloCycles/Second). We will need to set both the T1154 Transmitter to transmit to the ship and the R1155 Receiver to receive the ship's response. You can have preset frequencies for three frequency ranges, but these frequencies are set via the Mission Editor. It is possible to manually adjust a frequency, but it isn't necessarily recommended due to the difficulty to be precise. Using MF frequencies is better suited for communications over long distances, especially for naval missions of the RAF Coastal Command. You could, for instance, gain information from friendly ships to hunt for U-Boats or other German naval forces.

Since we cover a frequency in the third frequency range (yellow range), we will use the trailing antenna. The T1154/R1155 radio can cover three sets of frequency ranges:

- **Blue Range 1 (HF, with Fixed Antenna):** 10.0 MHz to 5.5 MHz
- **Red Range 2 (HF, with Fixed Antenna):** 5.5 MHz to 3.0 MHz
- **Yellow Range 3 (MF, with Trailing Antenna):** 500 KHz to 200 KHz

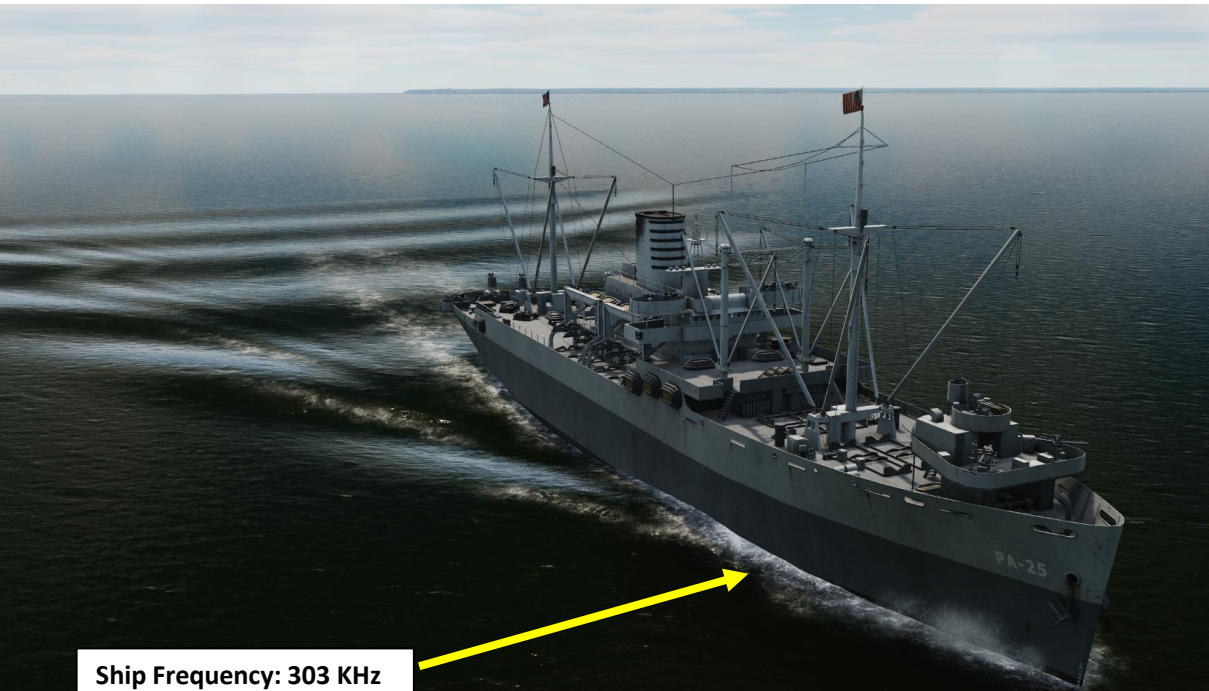

Ship Frequency: 303 KHz



T.1154N Range 3

Preset S	< > 444	kHz	AM
Preset T	< > 421	kHz	AM
Preset U	< > 303	kHz	AM
Preset V	< > 300	kHz	AM
Preset W	< > 270	kHz	AM
Preset X	< > 260	kHz	AM
Preset Y	< > 250	kHz	AM
Preset Z	< > 240	kHz	AM

**Preset Frequency "U"
Range 3 (Yellow) 303 KHz**

4 – T1154 & R1155 RADIO SET

4.3 – TRANSMISSION & RECEPTION TUTORIAL (MF)

1. Select the Navigator Seat by pressing “2”.
2. Since we transmit and receive on a MF frequency, we can use the Trailing Antenna.
3. Verify that you have sufficient altitude in order to avoid having the antenna tangle in anything on the ground.
4. Set the Trailing Antenna Reel Winch Brake Lever – OFF (AFT)
5. Left click on the Trailing Antenna Reel Winch to turn the crank counter-clockwise. This will extend the trailing antenna.
6. Crank until a few meters of antenna wire is extended.
7. Set the Trailing Antenna Reel Winch Brake Lever – ON (FWD)
8. Set T1154 Radio Transmitter Low Voltage Power Switch – ON (LEFT)
9. Set T1154 Radio Transmitter High Voltage Power Switch – ON (LEFT)

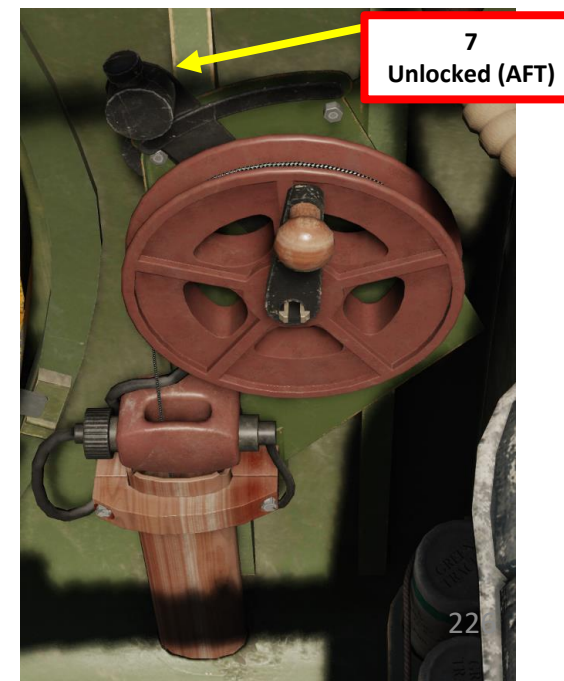
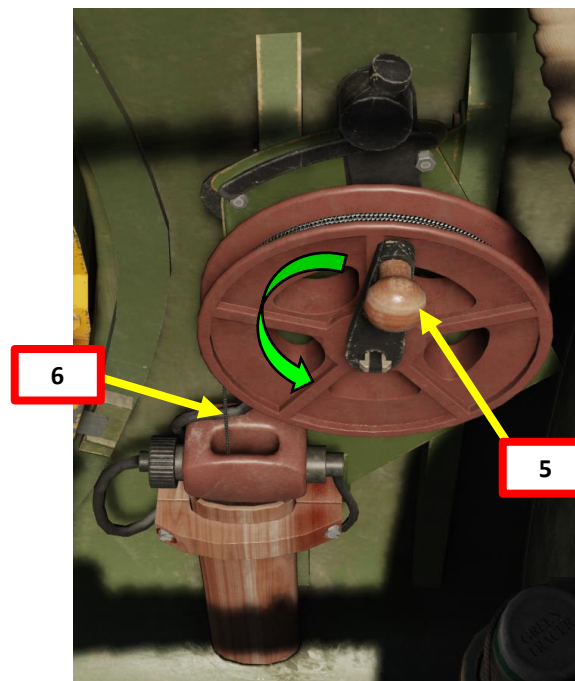
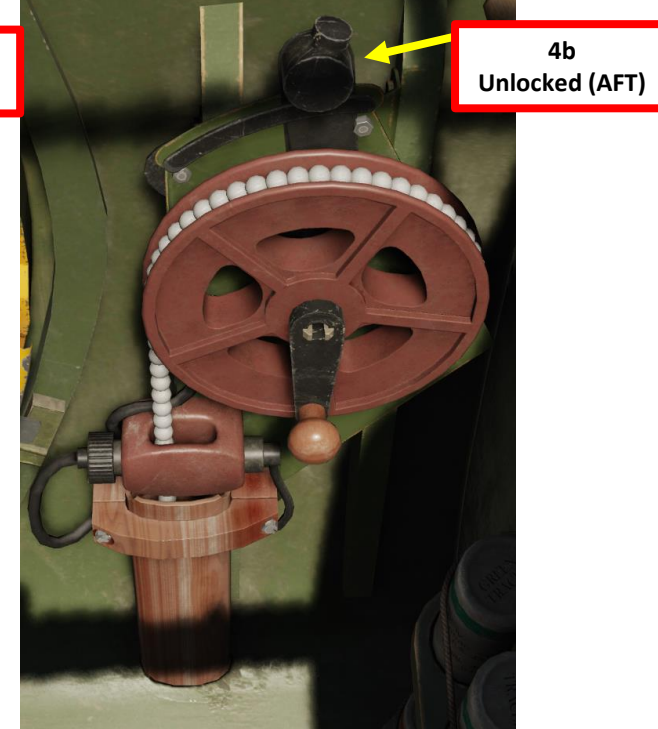
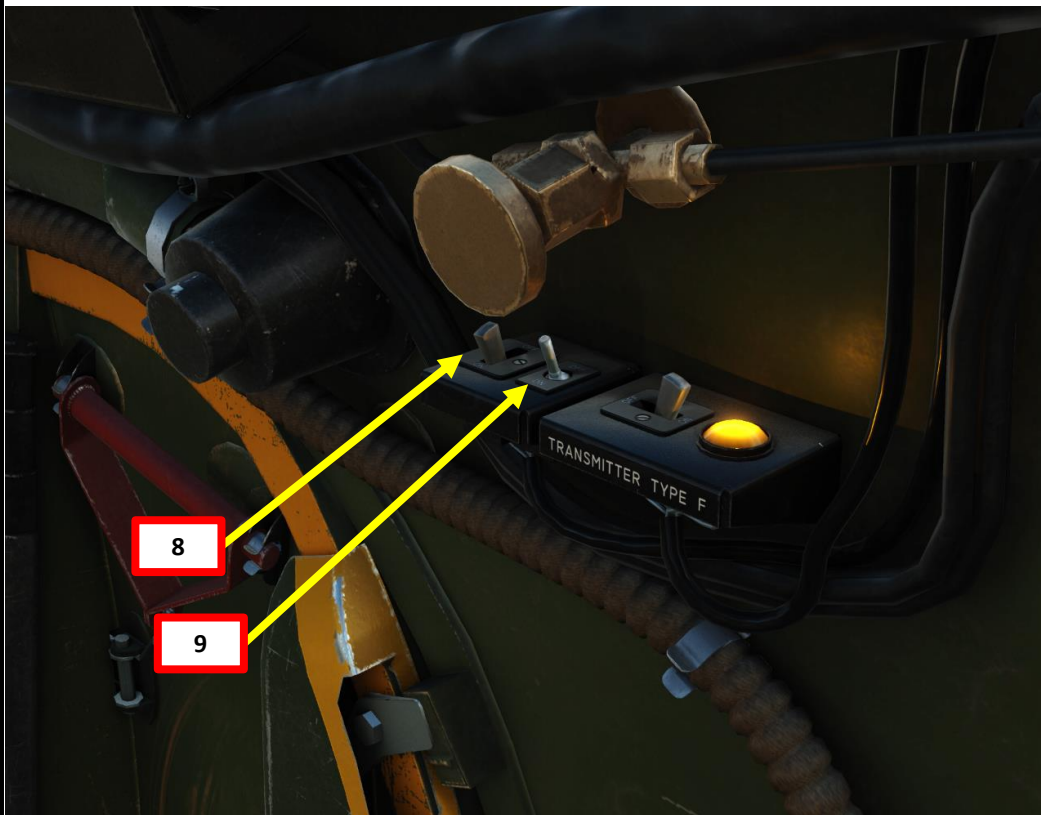

4 – T1154 & R1155 RADIO SET

4.3 – TRANSMISSION & RECEPTION TUTORIAL (MF)

10. Lower the armored headrest of the navigator seat to access the radio compartment by clicking on the headrest handle.
11. In low visibility conditions, I would advise you to turn on the Dome Light and use the flashlight (LALT+L).
12. Set T1154 Radio Transmitter Set Tuning Control knob to STD-BI (Standby) position.

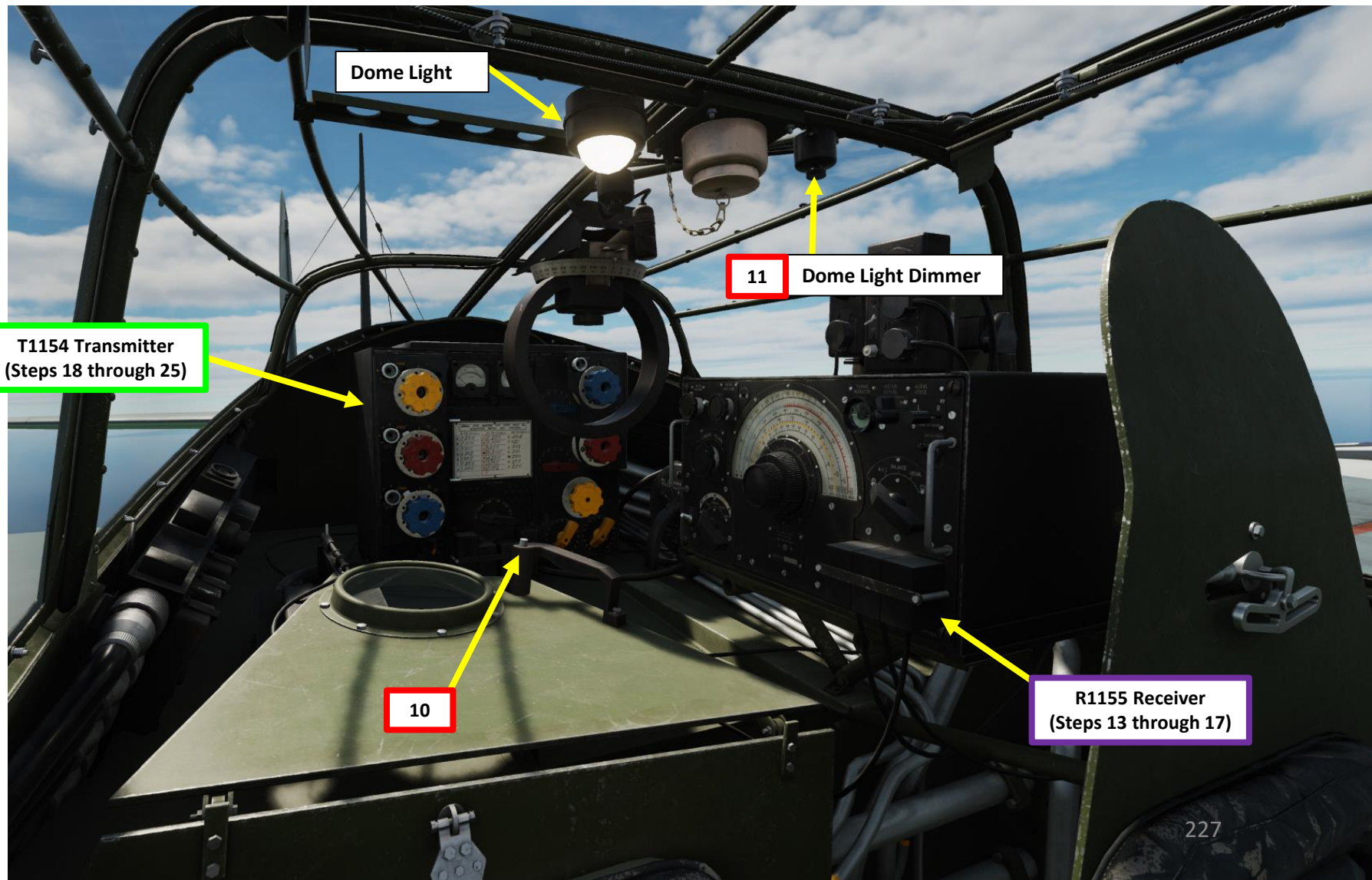
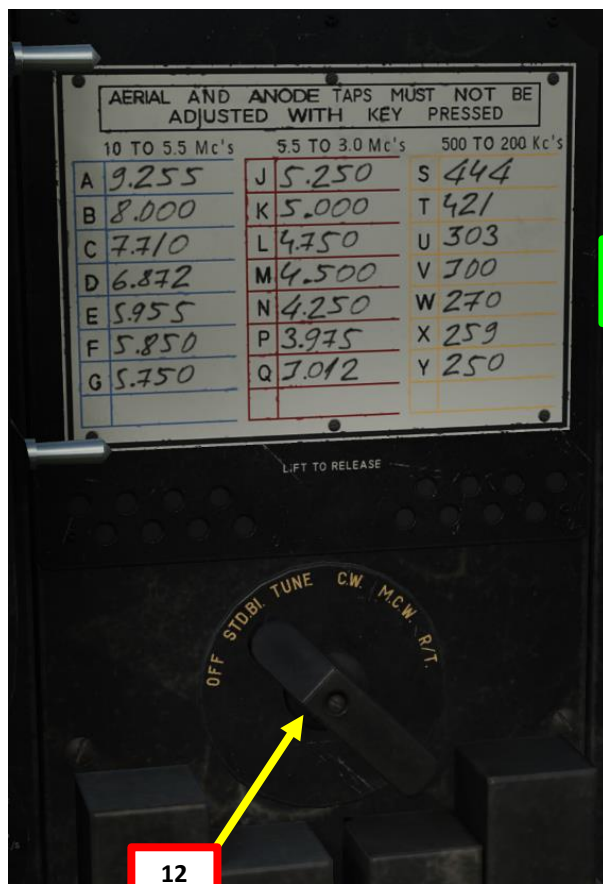

4 – T1154 & R1155 RADIO SET

4.3 – TRANSMISSION & RECEPTION TUTORIAL (MF)

13. Set R1155 Radio Receiver Set Master Selector Switch – Omni (O)
14. Confirm that the Tuning Indicator Light illuminates
15. Set the R1155 Radio Receiver Set Frequency Range Switch to the appropriate frequency range (“500/200” for frequency 303 KHz).
16. Use tuning knobs to set radio frequency needle to the appropriate frequency (303 KHz). Since we use the 500/200 frequency range, we use the second band from the bottom (in yellow).
 - Use the outer tuning knob for coarse tuning (big needle movements) and the inner tuning knob for fine tuning (small needle movements).
17. Adjust Volume Control.

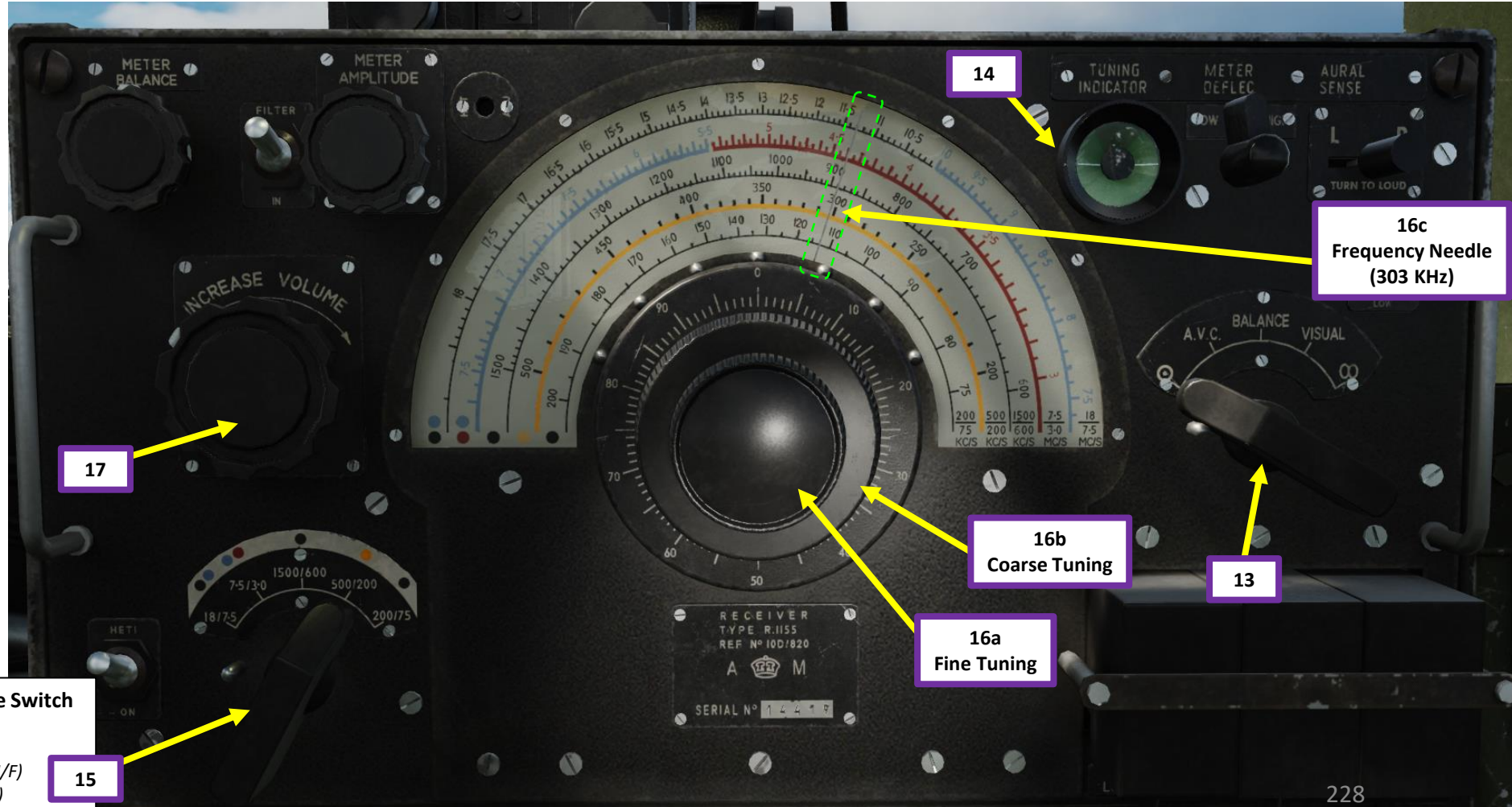

R1155 Radio Receiver Set Frequency Range Switch

- 18/7.5: Range from 18.5 MHz to 7.5 MHz (H/F)
- 7.5/3.0: Range from 7.5 MHz to 3.0 MHz (H/F)
- 1500/600: Range from 1500 KHz to 600 KHz (M/F)
- 500/200: Range from 500 KHz to 200 KHz (M/F)
- 200/75: Range from 200 KHz to 75 KHz (M/F)

16c
Frequency Needle
(303 KHz)

16b
Coarse Tuning

16a
Fine Tuning

4 - T1154 & R1155 RADIO SET

4.3 - TRANSMISSION & RECEPTION TUTORIAL (MF)

18. Set T1154 Radio Transmitter Set Tuning Control knob from STD-BI (Standby) position to TUNE position.
19. Set T1154 Radio Frequency Range Selector to the required frequency range. We want to transmit on Preset Channel "U", which is in the No. 3 Range (Yellow). Check the placard on the T1154 set to see which preset channel is in which range according to its color code.
20. To select Preset Frequency "U" (Frequency Range 3, Yellow):
 - a) Set Range 3 Master Oscillator Dial to "U".
 - b) Turn Range 3 Master Oscillating Tuning Condenser until it "clicks" (click-stop mechanism) when reaching the preset position near 303 KHz.
 - When the condenser "clicks", it becomes locked into position and can only be moved if the associated Master Oscillator Dial is reset to "FREE".

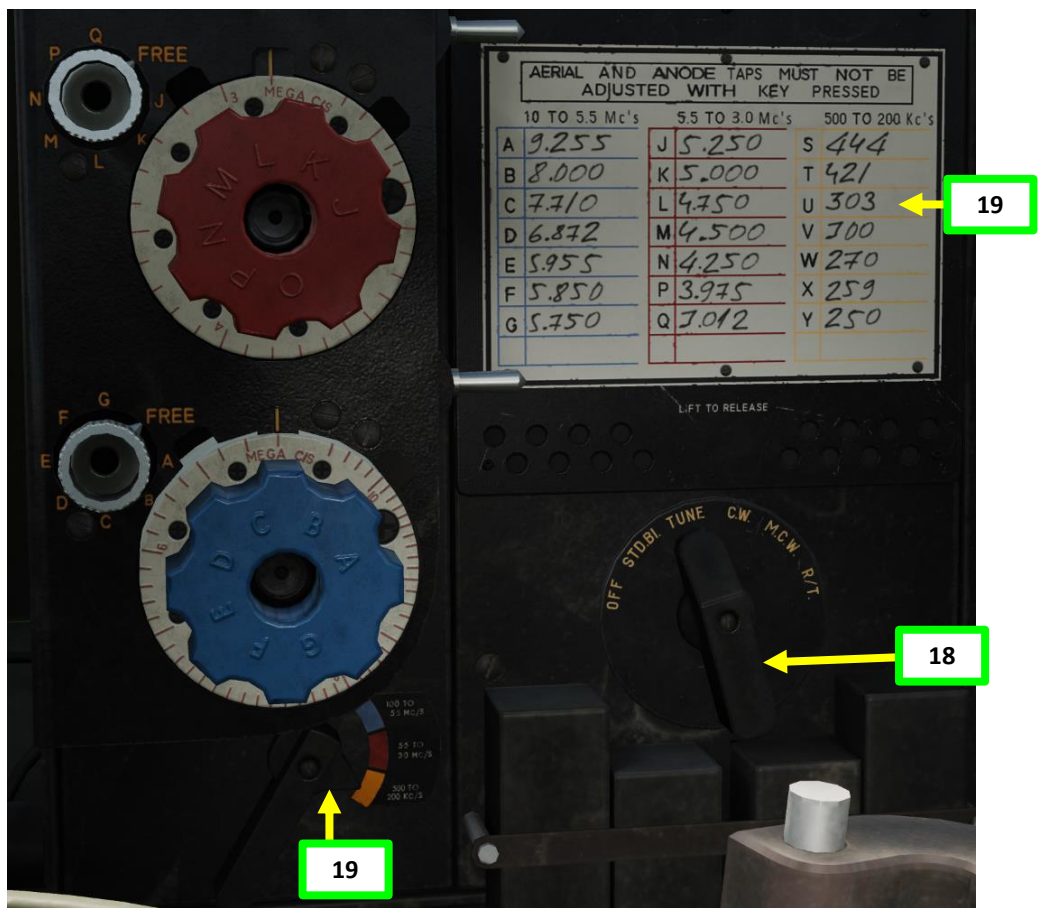
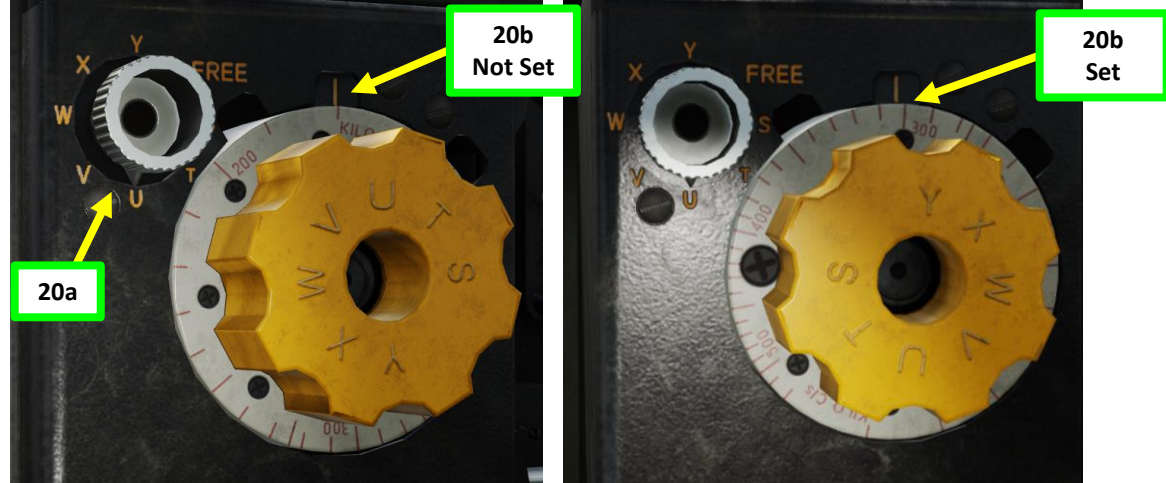

Note: If you want to tune the transmitter manually without using one of the preset frequencies, you can set the Master Oscillator for the condensers to "Free". This will unlock the condenser control and allow you to set it at any position you want. This step would only apply to step 20 a).

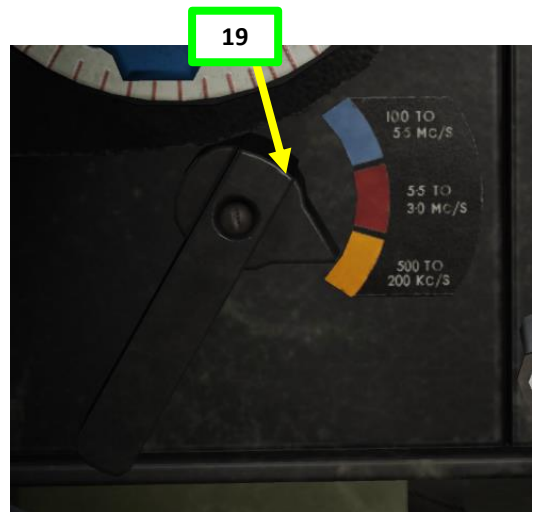

4 – T1154 & R1155 RADIO SET

4.3 – TRANSMISSION & RECEPTION TUTORIAL (MF)

21. Set T1154 Radio Transmitter Set Tuning Control knob to CW (Continuous Wave) position.
22. Press the T1154 Radio Morse Key. The default binding is "LALT + \". You should hear a morse "beep" through your headset.
23. While the T1154 Radio Morse Key is pressed, check Magnetic Feed and Amperemeter readings. If the values seem ok (they should be), you shouldn't need to adjust the Range 3 Output Circuit Tuning Condenser Control and the Range 3 Inductance Tapping switches.
24. If Magnetic Feed and Amperemeter readings are at 0 while the Morse Key is pressed:
 - a) Turn Range 3 Output Circuit Tuning Condenser Control and tap the T1154 Radio Morse Key until the Magnetic Feed and Amperemeter readings are acceptable while Morse Signal is sent.
 - b) Adjust Range 3 Inductance Tappings and tap the T1154 Radio Morse Key until the Magnetic Feed and Amperemeter readings are acceptable while Morse Signal is sent.

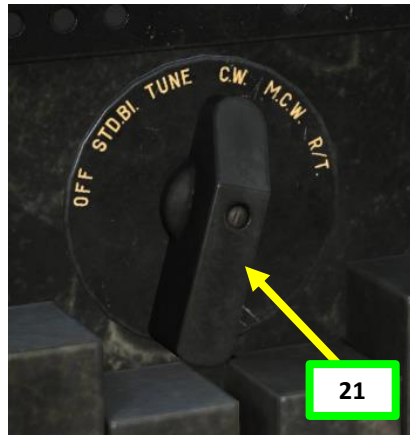

21

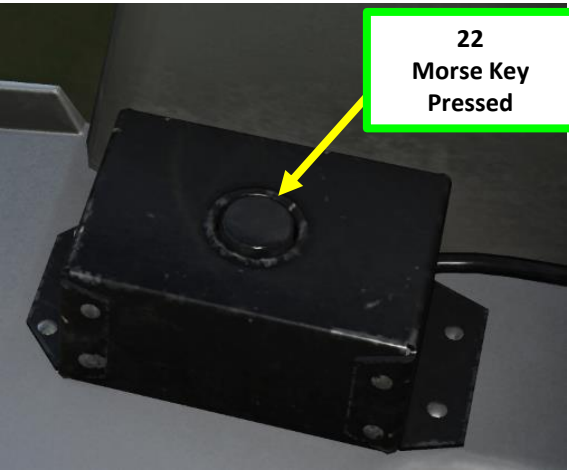

22
Morse Key
Pressed

23a
Morse Key
Not Pressed

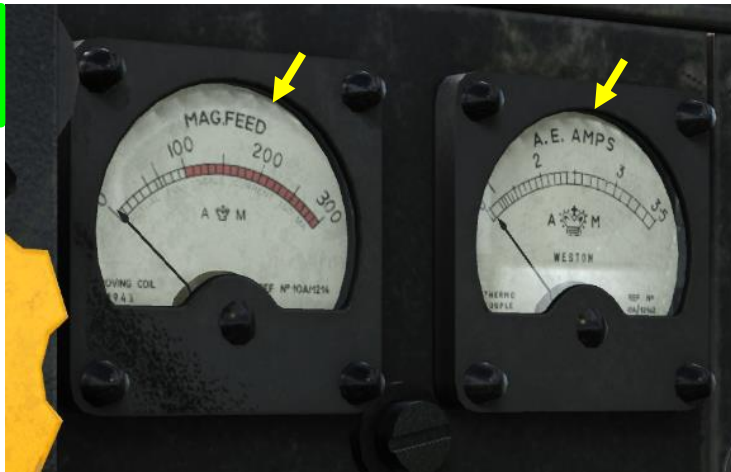

23b
Morse Key
Pressed

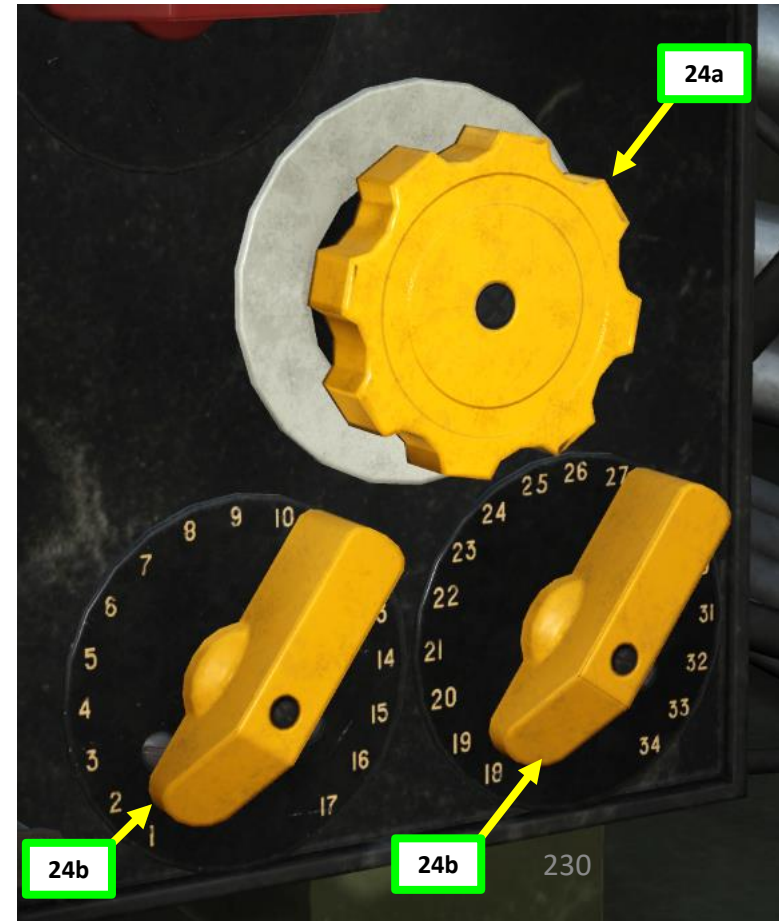
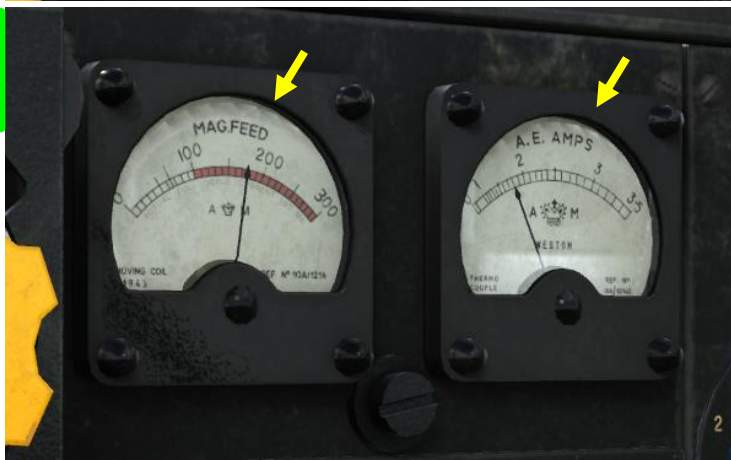

24a

24b

24b

4 – T1154 & R1155 RADIO SET

4.3 – TRANSMISSION & RECEPTION TUTORIAL (MF)

25. Now that we have set the transmitter frequency, set T1154 Radio Transmitter Set Tuning Control knob to R/T (Radio/Telephony). This will allow you to transmit voice signals.
26. Set Aerial (Antenna) Mode Selector – NORMAL

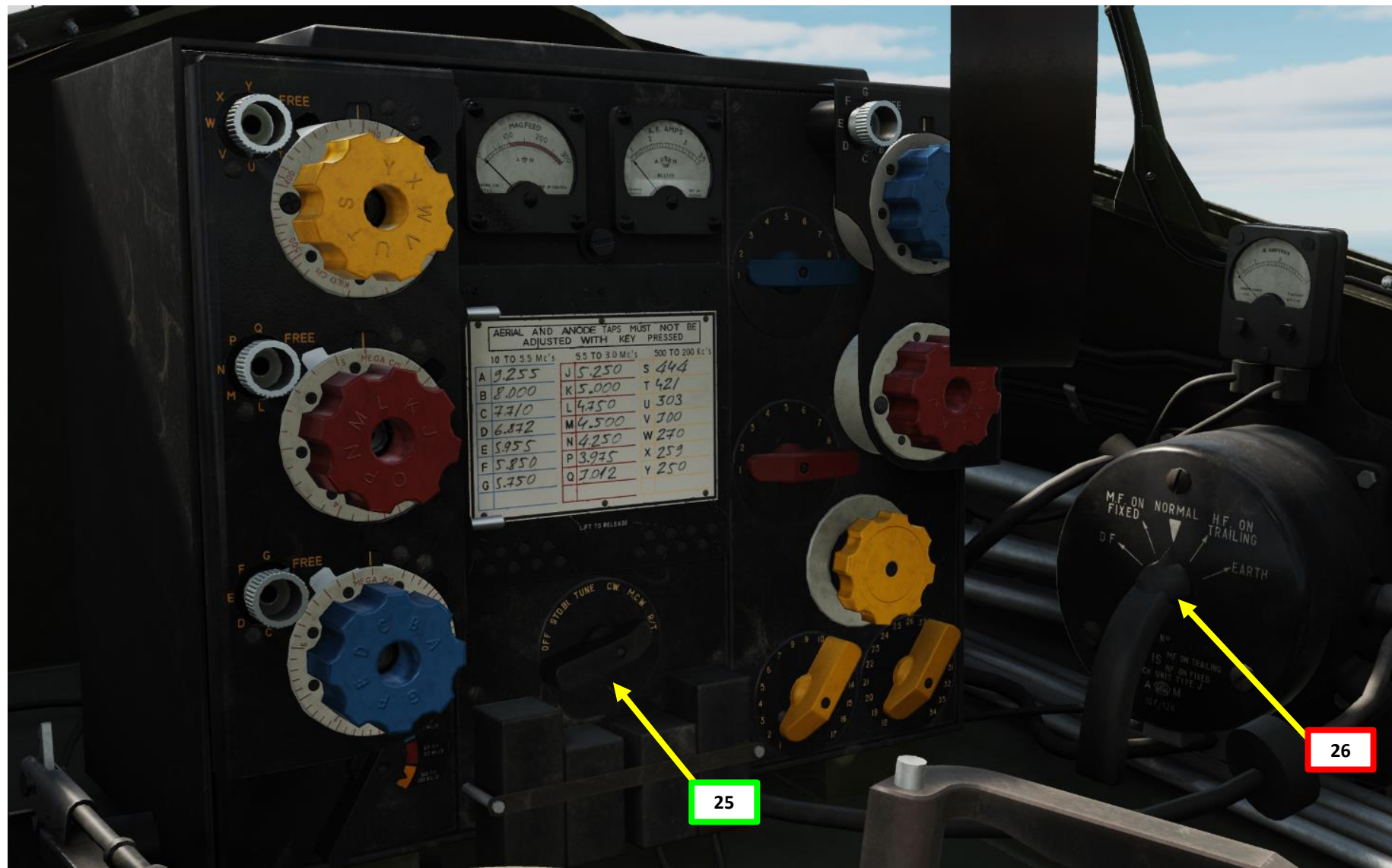

26

25

4 – T1154 & R1155 RADIO SET

4.3 – TRANSMISSION & RECEPTION TUTORIAL (MF)

27. Now that we have set both the T1154 Transmitter and the R1155 Receiver, we can communicate with the ship.
28. Press the T1154 Radio Morse Key to transmit on the set frequency. The default binding is "LALT + \".
29. Don't forget to reel the trailing antenna back in once you no longer need to use it.

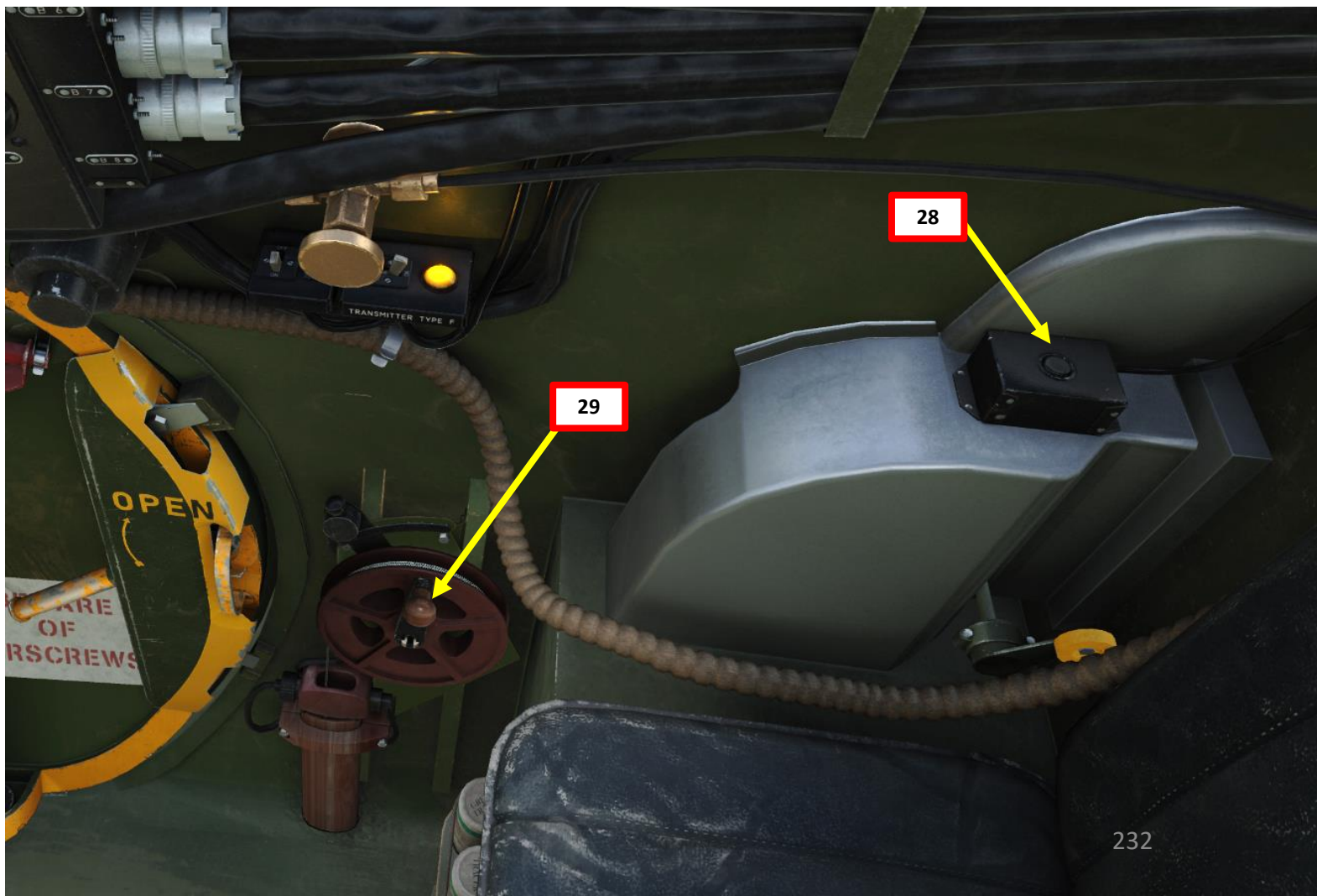
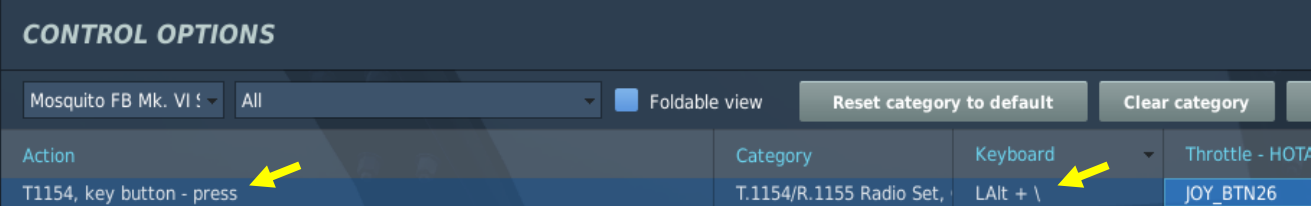

SECTION STRUCTURE

- 1 – The Role of a Navigator
- 2 – Navigation Systems Overview
- 3 – P-8 Magnetic Compass
 - 3.1 – Overview
 - 3.2 – Tutorial
- 4 – Remote Indicating (R.I.) Compass
- 5 – Direction Finding (D/F) System
 - 5.1 – Direction Finder System Components
 - 5.2 – Radio Emitter Setup
 - 5.3 – Aural D/F Tutorial
 - 5.4 – Visual D/F Tutorial
- 6 – A1271 Beam Approach System
- 7 – Magnetic Deviation
- 8 – Drift Recorder Device
- 9 – Oboe System
 - 9.1 – What is “Oboe”?
 - 9.2 – Principles Behind “Oboe”
 - 9.3 – Bombing Example with a Simulated “Oboe”

1 – THE ROLE OF A NAVIGATOR

Back in the Second World War, the role of a navigator was of prime importance. The right seat of the Mosquito certainly wasn't for leisure; navigation was a more complex task than meets the eye. The book "Terror in the Starboard Seat" by Dave McIntosh, a Canadian Mosquito navigator, gives a unique insight about what it felt like to be in that position.

In the Mosquito, the Navigator had a number of roles:

- Flight Plan management. This includes leg distances, ETA (Estimated Time of Arrival), wind drift, altitudes, airspeeds, weather reports, magnetic variation, fuel planning, and landmarks for navigation fixes.
- Managing the fuel by keeping an eye on the fuel gauges and switching to the correct fuel tanks when necessary.
- Managing the fire extinguishers
- Managing the propeller feathering
- Managing the emergency hydraulic pump
- Managing the bomb arming panel
- Reporting observations during flight (troop movements, encountered aircraft, anti-air batteries)
- Managing the T1154 Radio Transmitter and R1155 Radio Receiver Sets
- Managing D/F (Direction Finder) system
- Checking for enemy aircraft at the back
- Setting the IFF (Identify-Friend-or-Foe) codes when landing
- Firing the Flare gun with the correct flare color when landing (which was very important since the light code determined whether you would get shot at by your homing airfield's defenses or not)
- Setting the Identification Lights when landing (for identification purposes similar to the flare gun)

In this section, we will concentrate on navigation only. The reason why I insist on the importance of a navigator is that the Mosquito had to navigate over long distances and often had to fly at tree-top level. This makes navigation very difficult since the slightest mistake can throw you off course by miles over a long distance... which is very dangerous when you are lost over enemy territory. Flying at these altitudes while dodging power lines, trees and buildings requires a lot of concentration from the pilot, who doesn't have the time to take a map and do the (many) tasks of the navigator.

Here are two videos that provide an overview of the principles of Low Level Navigation:

RAF Low Flying Navigation PART 1/2
<https://youtu.be/NQWZEVaoFKQ>

RAF Low Flying Navigation PART 2/2
<https://youtu.be/C6oGa1bqe1U>





1 – THE ROLE OF A NAVIGATOR

When planning a flight, the general rule of thumb was to set a cruising speed of 240 mph, which gives you 4 nautical miles travelled per minute. Using these rules, navigators would mark on their map intervals of 4 miles, which correspond to 1 minute of flight time at 240 mph. The time of takeoff is written down on a flight report sheet (usually initialed A.B. for “Airborne”), then the navigator can calculate a travelled distance of about:

- 4 miles travelled per minute when flying at low altitudes at 240 mph with both engine operating
- 3 miles travelled per minute when flying at low altitudes at 180 mph with one engine operating

Flight plan information would have the required airspeed, altitude, IAS (Indicated Airspeed in mph), TAS (True Airspeed) in mph, the course, the drift, the true heading, the magnetic variation, the magnetic heading, the ground speed, the distance, the time, and the Estimated Time of Arrival (ETA). On top of that, the navigator has to make sure the fuel consumption matches the planned values as per the engine regime (see MERLIN 25 ENGINE FUEL CONSUMPTION table in the Engine & Fuel Management section). The FAA has a whole chapter on Navigation, which I recommend you read if that interests you: https://www.faa.gov/regulations_policies/handbooks_manuals/aviation/phak/media/18_phak_ch16.pdf

Pay special attention to the Wind Triangle section, which can come in very handy.





DH-98 MOSQUITO
FB MK VI

PART 12 - NAVIGATION

1 - THE ROLE OF A NAVIGATOR

Flight Plan Example

Source: 384th Bombardment Group (Heavy) in World War II

<http://photos.384thbombgroup.com/picture.php?109342>

<http://photos.384thbombgroup.com/picture.php?109343>

BAMFROIT - FLIGHT PLAN																																																																																																																																																																																																																																																											
PILOT <i>E. L. RAY</i> 117 LT				NAVIGATOR <i>M. S. LEAD</i> 200 LT				DATE <i>28 MAY 1944</i>																																																																																																																																																																																																																																																			
STATIONS OF INTEREST TAXI 0905 TO 0920																																																																																																																																																																																																																																																											
LEWIS BASE <i>BIGGLISWAD 1900 111</i>																																																																																																																																																																																																																																																											
COAST OUT <i>1138</i>																																																																																																																																																																																																																																																											
ENEMY COAST <i>1202</i>																																																																																																																																																																																																																																																											
LP <i>1247</i>																																																																																																																																																																																																																																																											
TARGET <i>1258</i>																																																																																																																																																																																																																																																											
ENEMY COAST <i>1342</i>																																																																																																																																																																																																																																																											
SUN			MOON			TWILIGHT																																																																																																																																																																																																																																																					
Rises	Sets		Rises	Sets		AM	PM																																																																																																																																																																																																																																																				
WATCH <i>Fast Slow RATE sec/hour Looking</i>																																																																																																																																																																																																																																																											
ZERO HOUR <i>1100</i> M CMT <i>21200 6000 FRUIT</i>																																																																																																																																																																																																																																																											
CRUISE <i>190 150 FT / MIN SWIP 7057 DISPERAL 332</i>																																																																																																																																																																																																																																																											
FROM	TO	W/V USED	HEIGHT	IAS MPH	T.A.S. (K)	CORR SE	DRI-FT	TRUE HDNG	VAR.	MAC HDNG.	C. S.	DIST.	TIME	E.T.A.	CELESTIAL DATE																																																																																																																																																																																																																																												
<table border="1"> <thead> <tr> <th>TIME</th> <th>COURSE</th> <th>W/V USED</th> <th>TRUE HDNG.</th> <th>MAC HDNG.</th> <th>NAVIGATIONAL OBSERVATION</th> <th>GENERAL OBSERVATION</th> <th>IAS MPH</th> <th>HEIGHT</th> <th>T.A.S.</th> <th>RUN</th> <th>C.S.</th> <th>TO RUN</th> <th>E.T.A.</th> </tr> </thead> <tbody> <tr> <td>0926</td> <td></td> <td></td> <td></td> <td></td> <td>ENG. STARTED</td> <td></td> <td></td> <td></td> <td></td> <td></td> <td></td> <td></td> <td></td> </tr> <tr> <td>0905</td> <td></td> <td></td> <td></td> <td></td> <td>TAXI</td> <td></td> <td></td> <td></td> <td></td> <td></td> <td></td> <td></td> <td></td> </tr> <tr> <td>0925</td> <td></td> <td></td> <td></td> <td></td> <td>TAKE OFF</td> <td>CLEAR VIS-U</td> <td></td> <td></td> <td></td> <td></td> <td></td> <td></td> <td></td> </tr> <tr> <td>0945</td> <td></td> <td></td> <td></td> <td></td> <td>P. 52°24'N 00°33'W</td> <td>HAZE LAYER-2000 CLIMB TO 4000</td> <td>140</td> <td>4000</td> <td></td> <td></td> <td></td> <td></td> <td></td> </tr> <tr> <td>1000</td> <td></td> <td></td> <td></td> <td></td> <td>P. 52°28'N 00°41'W</td> <td>310 AS 11-14000</td> <td>140</td> <td>8000</td> <td></td> <td></td> <td></td> <td></td> <td></td> </tr> <tr> <td>1015</td> <td></td> <td></td> <td></td> <td></td> <td>P. 52°31'N 00°38'W</td> <td>HAZE LAYER-8000</td> <td>130</td> <td>12000</td> <td></td> <td></td> <td></td> <td></td> <td></td> </tr> <tr> <td>1030</td> <td></td> <td></td> <td></td> <td></td> <td>P. 52°24'N 00°45'W</td> <td></td> <td>140</td> <td>15000</td> <td></td> <td></td> <td></td> <td></td> <td></td> </tr> <tr> <td>1045</td> <td></td> <td></td> <td></td> <td></td> <td>P. 52°26'N 00°34'W</td> <td>VIS-U</td> <td>145</td> <td>18000</td> <td></td> <td></td> <td></td> <td></td> <td></td> </tr> <tr> <td>1100</td> <td></td> <td></td> <td></td> <td></td> <td>P. 52°24'N 00°39'W</td> <td></td> <td>140</td> <td>19500</td> <td></td> <td></td> <td></td> <td></td> <td></td> </tr> <tr> <td>1112</td> <td>240</td> <td>2017</td> <td>180</td> <td></td> <td>LV. MOLESWORTH</td> <td></td> <td>130</td> <td>20400</td> <td>168</td> <td>0</td> <td>0</td> <td>162</td> <td>19</td> <td>7</td> <td>1119</td> </tr> <tr> <td>1119</td> <td></td> <td>43</td> <td>125</td> <td></td> <td>LV. BIGGLISWADE</td> <td>WIND 2 HEADWINDS 265° 16 KTS</td> <td>130</td> <td>21000</td> <td>170</td> <td>0</td> <td>0</td> <td>181</td> <td>33</td> <td>12</td> <td>1131</td> </tr> <tr> <td>1131</td> <td>255</td> <td>16</td> <td>117</td> <td></td> <td>LV. SPLASHER #7</td> <td></td> <td>140</td> <td>21000</td> <td>172</td> <td>0</td> <td>0</td> <td>186</td> <td>23</td> <td>8</td> <td>1139</td> </tr> <tr> <td>1139</td> <td></td> <td></td> <td>124</td> <td></td> <td>LV. CLAXTON</td> <td>CONV. 5000 FT</td> <td>140</td> <td>21000</td> <td>172</td> <td>0</td> <td>0</td> <td>183</td> <td>20</td> <td>23</td> <td>1203</td> </tr> <tr> <td>1145</td> <td></td> <td></td> <td>124</td> <td></td> <td>LV. CLAXTON</td> <td>1140 P-38</td> <td>140</td> <td></td> <td>16</td> <td>6</td> <td>160</td> <td>54</td> <td>20</td> <td>1205</td> <td></td> </tr> <tr> <td>1151</td> <td>195</td> <td>30KTS</td> <td>141</td> <td></td> <td>ENEMY COAST</td> <td>9 WIND 195° 30 KTS</td> <td>140</td> <td></td> <td>29</td> <td>12</td> <td>145</td> <td>41</td> <td>17</td> <td>1208</td> <td></td> </tr> </tbody> </table>																TIME	COURSE	W/V USED	TRUE HDNG.	MAC HDNG.	NAVIGATIONAL OBSERVATION	GENERAL OBSERVATION	IAS MPH	HEIGHT	T.A.S.	RUN	C.S.	TO RUN	E.T.A.	0926					ENG. STARTED									0905					TAXI									0925					TAKE OFF	CLEAR VIS-U								0945					P. 52°24'N 00°33'W	HAZE LAYER-2000 CLIMB TO 4000	140	4000						1000					P. 52°28'N 00°41'W	310 AS 11-14000	140	8000						1015					P. 52°31'N 00°38'W	HAZE LAYER-8000	130	12000						1030					P. 52°24'N 00°45'W		140	15000						1045					P. 52°26'N 00°34'W	VIS-U	145	18000						1100					P. 52°24'N 00°39'W		140	19500						1112	240	2017	180		LV. MOLESWORTH		130	20400	168	0	0	162	19	7	1119	1119		43	125		LV. BIGGLISWADE	WIND 2 HEADWINDS 265° 16 KTS	130	21000	170	0	0	181	33	12	1131	1131	255	16	117		LV. SPLASHER #7		140	21000	172	0	0	186	23	8	1139	1139			124		LV. CLAXTON	CONV. 5000 FT	140	21000	172	0	0	183	20	23	1203	1145			124		LV. CLAXTON	1140 P-38	140		16	6	160	54	20	1205		1151	195	30KTS	141		ENEMY COAST	9 WIND 195° 30 KTS	140		29	12	145	41	17	1208	
TIME	COURSE	W/V USED	TRUE HDNG.	MAC HDNG.	NAVIGATIONAL OBSERVATION	GENERAL OBSERVATION	IAS MPH	HEIGHT	T.A.S.	RUN	C.S.	TO RUN	E.T.A.																																																																																																																																																																																																																																														
0926					ENG. STARTED																																																																																																																																																																																																																																																						
0905					TAXI																																																																																																																																																																																																																																																						
0925					TAKE OFF	CLEAR VIS-U																																																																																																																																																																																																																																																					
0945					P. 52°24'N 00°33'W	HAZE LAYER-2000 CLIMB TO 4000	140	4000																																																																																																																																																																																																																																																			
1000					P. 52°28'N 00°41'W	310 AS 11-14000	140	8000																																																																																																																																																																																																																																																			
1015					P. 52°31'N 00°38'W	HAZE LAYER-8000	130	12000																																																																																																																																																																																																																																																			
1030					P. 52°24'N 00°45'W		140	15000																																																																																																																																																																																																																																																			
1045					P. 52°26'N 00°34'W	VIS-U	145	18000																																																																																																																																																																																																																																																			
1100					P. 52°24'N 00°39'W		140	19500																																																																																																																																																																																																																																																			
1112	240	2017	180		LV. MOLESWORTH		130	20400	168	0	0	162	19	7	1119																																																																																																																																																																																																																																												
1119		43	125		LV. BIGGLISWADE	WIND 2 HEADWINDS 265° 16 KTS	130	21000	170	0	0	181	33	12	1131																																																																																																																																																																																																																																												
1131	255	16	117		LV. SPLASHER #7		140	21000	172	0	0	186	23	8	1139																																																																																																																																																																																																																																												
1139			124		LV. CLAXTON	CONV. 5000 FT	140	21000	172	0	0	183	20	23	1203																																																																																																																																																																																																																																												
1145			124		LV. CLAXTON	1140 P-38	140		16	6	160	54	20	1205																																																																																																																																																																																																																																													
1151	195	30KTS	141		ENEMY COAST	9 WIND 195° 30 KTS	140		29	12	145	41	17	1208																																																																																																																																																																																																																																													

FLIGHT RECORD												
TIME	COURSE	W/V USED	TRUE HDNG.	MAC HDNG.	NAVIGATIONAL OBSERVATION	GENERAL OBSERVATION	IAS MPH	HEIGHT	T.A.S.	RUN	C.S.	
1158	130	33	146		51°21'N 02°13'E	170° 33 KTS	140	21000	172	0	0	156
1206			146		LV ENCT 00°33'E		140	21000	172	0	0	157
1215			138		P. 50°51'N 02°55'E		140	21000	172	0	0	152
1228			138		50°45'N 03°36'E	P-38	140	21000	172	0	0	156
1230			111		50°42'N 03°41'W	CLEAR VIS U	140		17	7	149	
1239			120		50°38'N 04°43'E	P-47	140		43	16	161	
1244			123		50°31'N 05°00'E		140	21000	172	0	0	142
1254			151		50°22'N 05°34'E		140	21000	172	0	0	140
1259			081		50°23'N 05°53'E	CLEAR VIS U	140	21000	172	0	0	170
1307			052		50°28'N 00°16'E STARTING DIVE	AL CU 2/10	140	19500				
1309			052		BOMBS AWAY	SMOKE SCREEN 4 TORRE	140	19500				
1315			331		50°52'N 06°33'E P	IN HAZE IN CITY ROTHERS SIDE RIVE	140	20100	172			
1319			300		50°55'N 06°30'E P	P-47 P-38	140	20200	172	0	0	149
1329			296		51°27'N 05°33'E P	FLAK EINDHOVEN	140					
1336			295		51°23'N 05°27'E P		140	18000	172	0	0	196
1339			293		51°23'N 04°47'E P		140					
1350			291		51°03'N 04°42'E P LV ENCT	CLEAR	140	15000	172	0	0	190
1354			297		51°05'N 03°25'E P	CLEAR VIS U	140					
1404			265		52°06'N 02°42'E		140	10000				46 14 197
1408			265		52°06'N 02°32'E		140	8000				52 18 197
1421			271		52°06'N 02°35'E	BOAT 500'	140	4000				0 0 135
1435			295			OLD BASE 3000 31310 AL CU	140	3000				
1456			183		OVER BASE							
1511					LANDED							
1520					ENG OFF							

See 145

236
SIGNED *Anneth S. L...*

1 – THE ROLE OF A NAVIGATOR

Other tools of the navigator were the conversion charts.

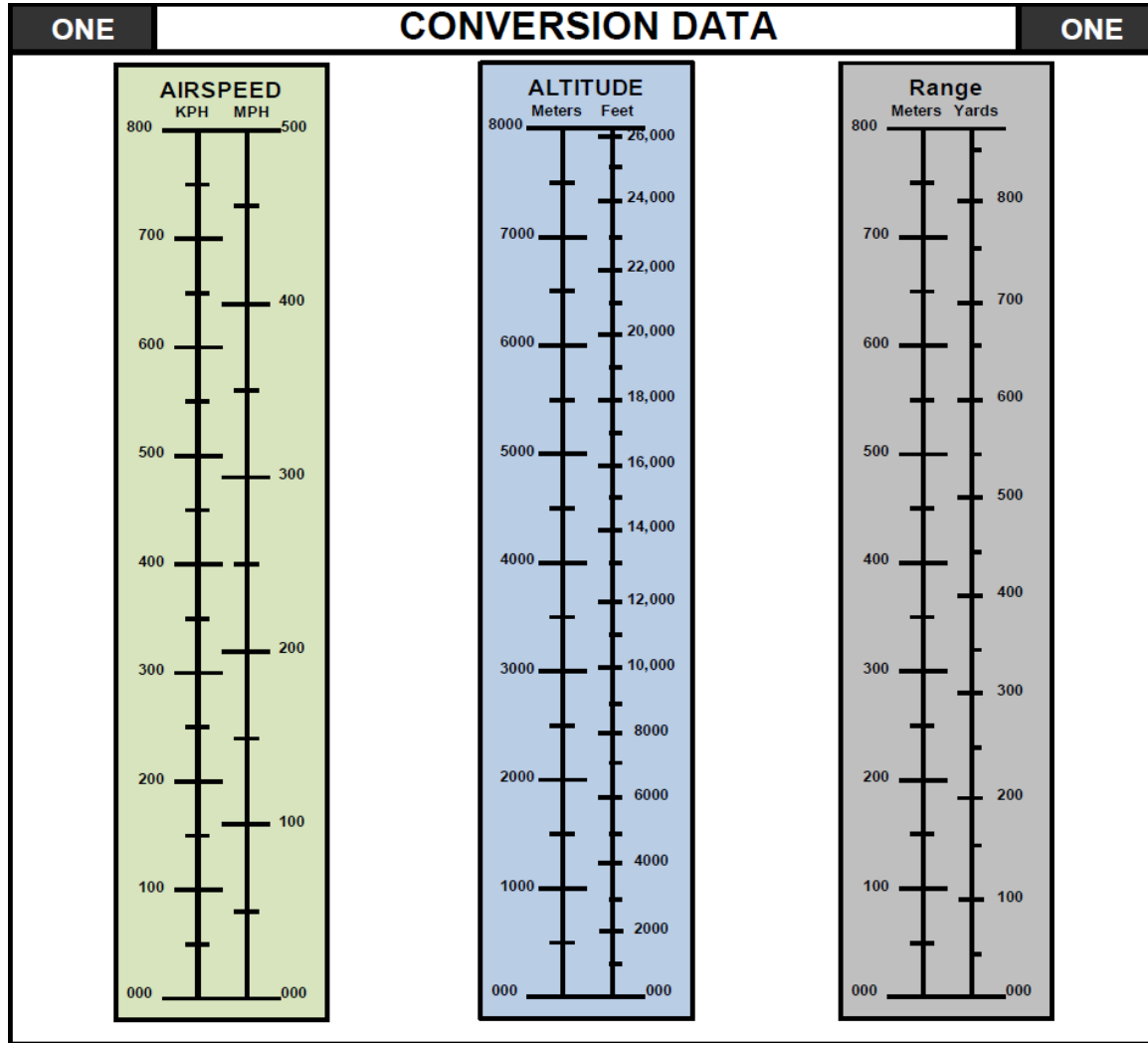

Airspeed Definitions (« ICE T »)

- **Indicated Airspeed (IAS):** This is the airspeed indicated on your airspeed indicator. This is the airspeed measured from the raw dynamic pressure of the outside air entering a pitot tube.
- **Calibrated Airspeed (CAS):** This is the Indicated Airspeed corrected for position installation (instrument calibration) errors.
- **Equivalent Airspeed (EAS):** This is the Calibrated Airspeed corrected for air compressibility. In other words, it is defined as the speed at sea level, under ISA (International Standard Atmosphere) conditions, that would produce the same incompressible dynamic pressure that is produced at the true airspeed and the altitude at which the vehicle is flying.
- **True Airspeed (TAS):** This is the Equivalent Airspeed corrected for temperature and pressure altitude. Think of this as speed of the aircraft relative to the airmass (air density, which changes with altitude) in which it is flying. At sea level in the ISA conditions, and at slow speeds where air compressibility is negligible, IAS corresponds to TAS.
- **Ground Speed (GS):** This is the horizontal speed of an aircraft relative to the Earth's surface. This is what the navigator uses to determine arrival times to the waypoints of a flight plan. The way to approximate your ground speed is to have the aircraft fly level, obtain the True Airspeed and then perform the vector sum of the aircraft's true airspeed and the current wind speed and direction; a headwind subtracts from the ground speed, while a tailwind adds to it. Winds at other angles to the heading will have components of either headwind or tailwind as well as a crosswind component.

International Civil Aviation Organization International Standard Atmosphere							
Temperature		Altitude Above Sea Level		Atmospheric Pressure			Mach 1
°F	°C	feet	meters	inches Hg	mm Hg	psia	mph
59	15	SL	0	29.92	760	14.70	761
55	13	1000	305	28.86	733	14.17	758
52	11	2000	610	27.82	706	13.67	755
48	9	3000	914	26.82	681	13.17	752
45	7	4000	1219	25.84	656	12.69	750
41	5	5000	1524	24.90	632	12.23	748
38	3	6000	1829	23.98	609	11.78	745
34	1	7000	2134	23.09	586	11.34	742
31	-1	8000	2438	22.22	564	10.92	740
27	-3	9000	2743	21.39	543	10.51	736
23	-5	10000	3048	20.58	523	10.10	734
5	-15	15000	4572	16.89	429	8.29	720
-13	-25	20000	6096	13.75	349	6.75	706
-31	-35	25000	7620	11.10	282	5.45	693



1 - THE ROLE OF A NAVIGATOR

In addition to charts, "Mechanical Flight Computers" could be used to obtain various information quickly by moving one face and use scales as a reference. Lots of these are still used today in flight schools.

Pressure Conversion
Inches of Mercury to Millibars

Formula: 1,000 Millibars = 29.53 Inches of Mercury.

505	15.0	660	19.6	815	24.0	970	28.8
510	15.2	665	19.8	820	24.2	975	28.8
515	15.4	670	20.0	825	24.4	980	29.0
520	15.6	675	20.2	830	24.6	985	29.2
525	15.8	680	20.4	835	24.8	990	29.4
530	16.0	685	20.6	840	25.0	995	29.6
535	16.2	690	20.8	845	25.2	1000	29.8
540	16.4	695	21.0	850	25.4	1005	29.8
545	16.6	700	21.2	855	25.6	1010	30.0
550	16.8	705	21.4	860	25.8	1015	30.2
555	17.0	710	21.6	865	26.0	1020	30.4
560	17.2	715	21.8	870	26.2	1025	30.6
565	17.4	720	22.0	875	26.4	1030	30.8
570	17.6	725	22.2	880	26.6	1035	31.0
575	17.8	730	22.4	885	26.8	1040	31.2
580	18.0	735	22.6	890	27.0	1045	31.4
585	18.2	740	22.8	895	27.2	1050	31.6
590	18.4	745	23.0	900	27.4	1055	31.8
595	18.6	750	23.2	905	27.6	1060	32.0
600	18.8	755	23.4	910	27.8	1065	32.2
605	19.0	760	23.6	915	28.0	1070	32.4
610	19.2	765	23.8	920	28.2	1075	32.6
615	19.4	770	24.0	925	28.4	1080	32.8
620		775		930	28.6	1085	33.0
625		780		935	28.8	1090	33.2
630		785		940	29.0	1095	33.4
635		790		945	29.2	1100	33.6
640		795		950	29.4	1105	33.8
645		800		955	29.6	1110	34.0
650		805		960	29.8	1115	34.2
655		810		965	30.0	1120	34.4
660		815		970	30.2	1125	34.6

Student E6B Flight Computer

Front

Back

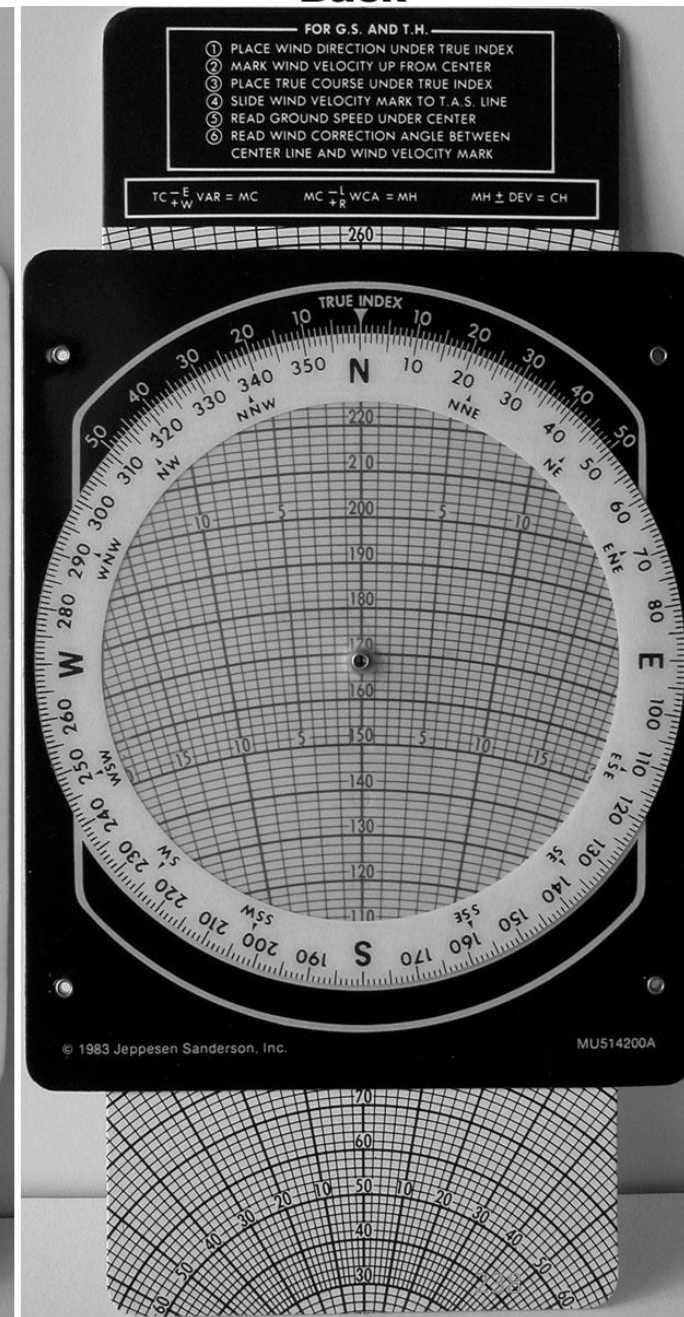
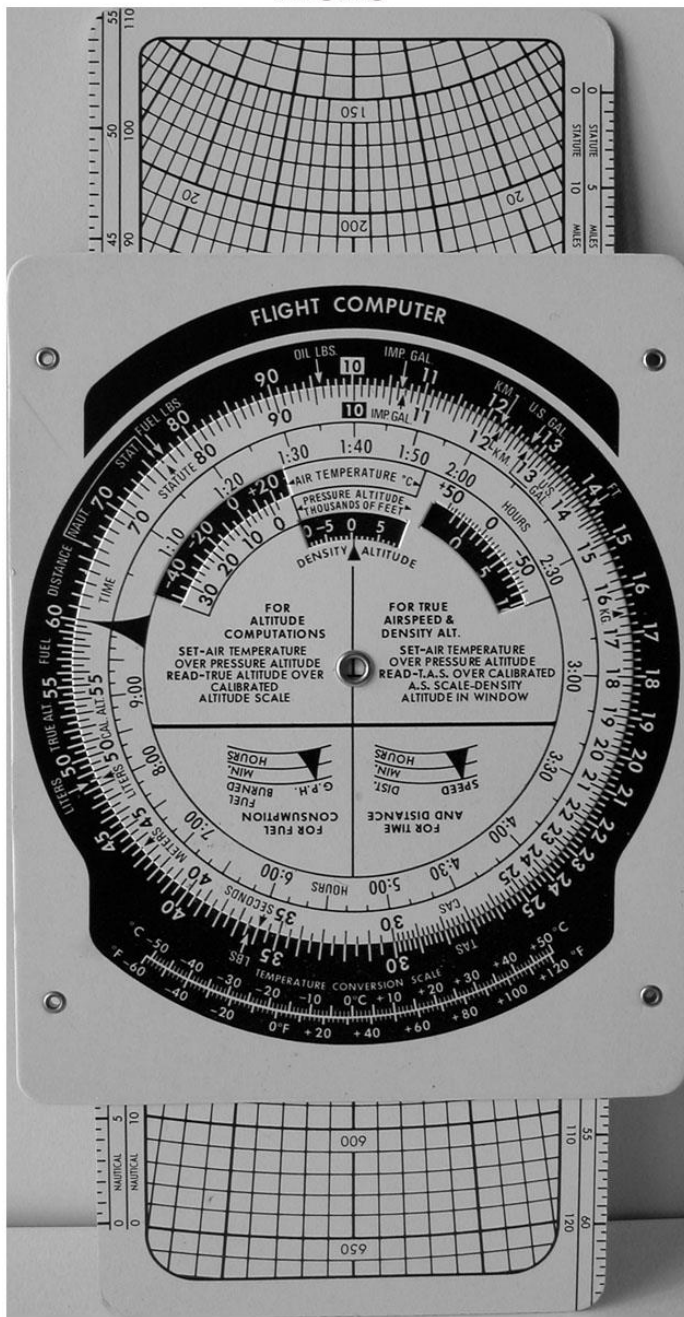

2 – NAVIGATION SYSTEMS OVERVIEW

The Mosquito has a number of navigation systems that can help the crew orient itself. This section is just a general overview of what systems are available in the aircraft. More details are available in the following sub-sections.

- The **P-8 Magnetic Compass** provides the aircraft magnetic heading.
- The **Directional Gyro** provides an adjustable heading that has to be re-calibrated as the aircraft gyros accumulate drift error. The P-8 magnetic compass is used as a reference.
- The **Remote Indicating (R.I.) compass** is also used to determine aircraft heading.
- The **A1271 Beam Approach system** is used to approach an airfield from a specific direction in low visibility conditions. You can see this as a primitive form of ILS (Instrument Landing System) with lateral deviation information but no glide slope information.

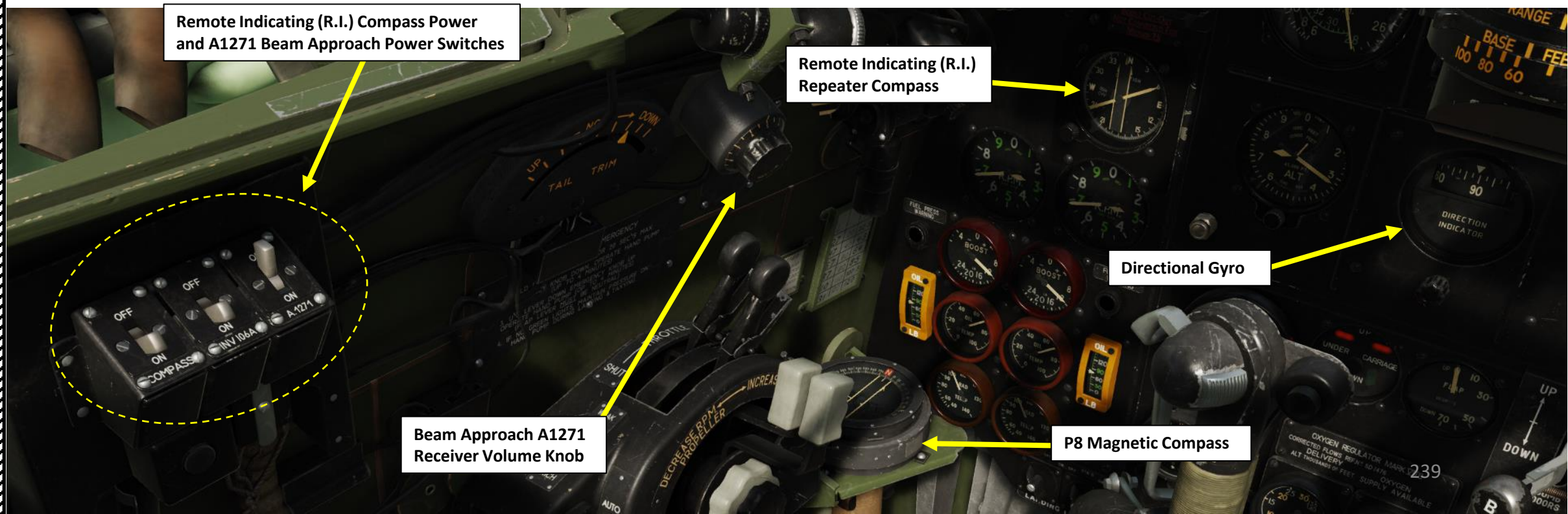

Remote Indicating (R.I.) Compass Power and A1271 Beam Approach Power Switches

Remote Indicating (R.I.) Repeater Compass

Directional Gyro

Beam Approach A1271 Receiver Volume Knob

P8 Magnetic Compass

2 – NAVIGATION SYSTEMS OVERVIEW

- The **R1155 Radio Receiver** and **T1154 Radio Transmitter** are used to select specific navigation aid frequencies to track for direction finding.
- Direction Finding can be performed by either using the **Direction Finding Visual Indicator** or by turning the **D/F Loop Aerial** and using the changing sound signal volume to determine the direction to a signal source.
- The **Aerial Mode Selector** is use to select whether the radio antennas are used for communication or for direction finding.

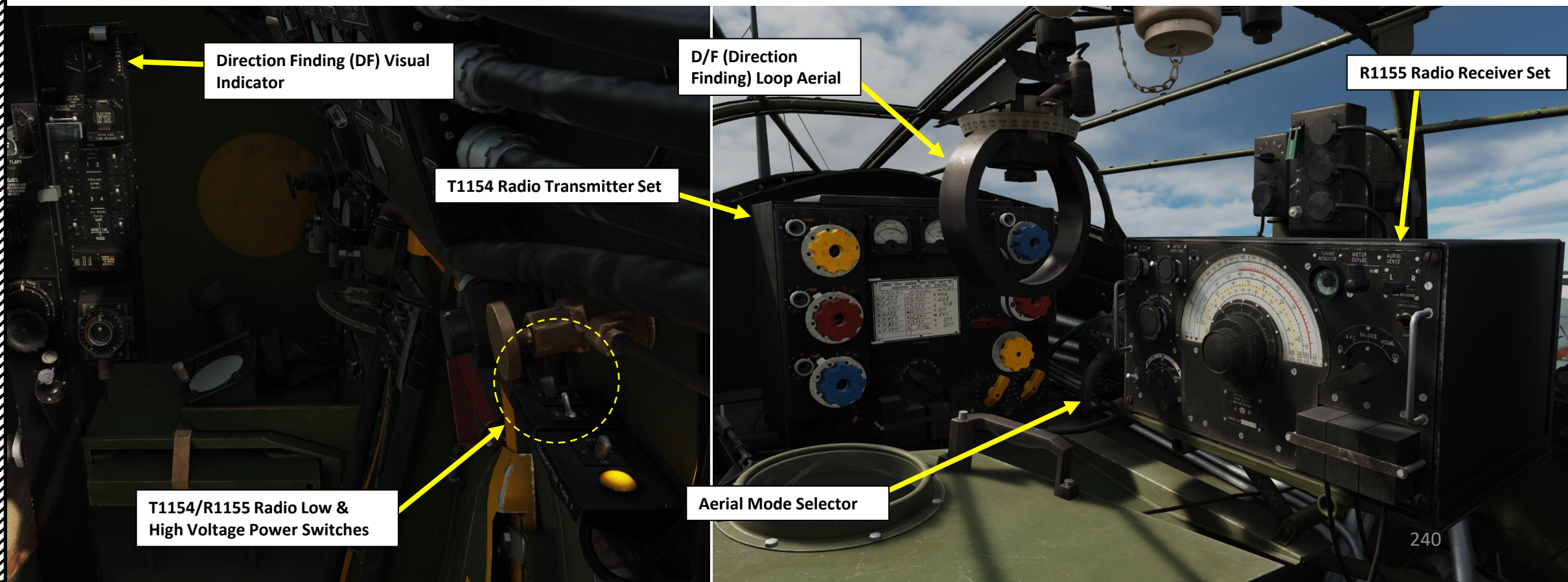

Direction Finding (DF) Visual Indicator

D/F (Direction Finding) Loop Aerial

R1155 Radio Receiver Set

T1154 Radio Transmitter Set

T1154/R1155 Radio Low & High Voltage Power Switches

Aerial Mode Selector

2 – NAVIGATION SYSTEMS OVERVIEW

- The Periscopic Drift Sight allows the navigator to determine drift angle due to the winds.

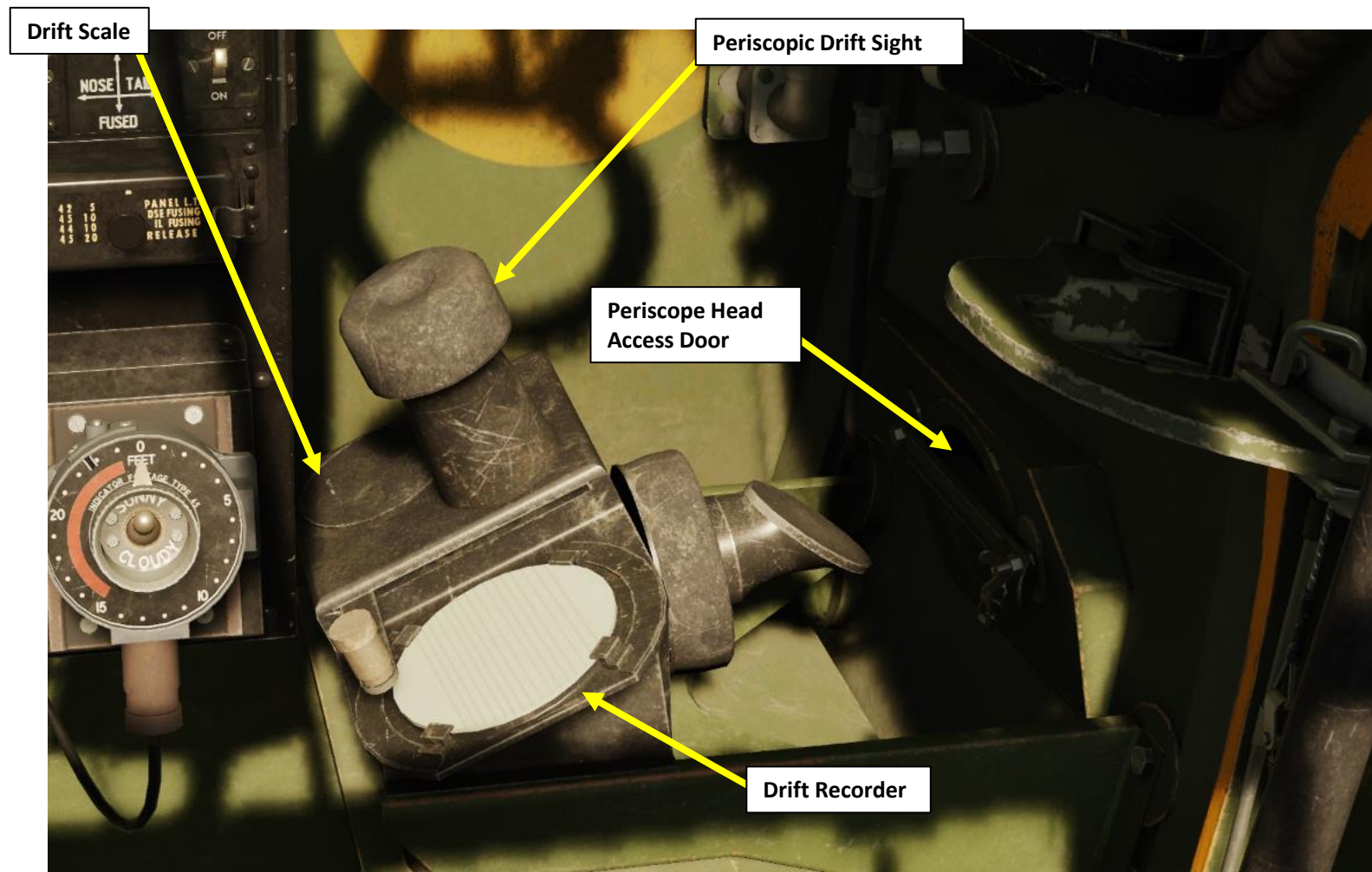

3 – P-8 MAGNETIC COMPASS

3.1 – Overview

The aircraft’s navigation equipment consists of the P-8 magnetic compass installed on the central part of the aircraft dashboard’s lower section, as well as the Mk 1 gyroscope on the instrument panel for instrument flying.

The main part of the compass is a magnetic compass system, which bears the name of the compass rose. The compass rose, a sensitive element consisting of a system of magnets, antennae, damping wires, a compass cap, centre-pin and hollow float, which reduces the weight of the compass rose in the liquid.

The gyroscope does not automatically indicate course and instead indicates the deviation from any given course, measured by the magnetic compass P8. It requires re-calibration after a few minutes of flight.

Here are two great video tutorials on the P8 compass:

Dreamsofwings Spitfire P8 Tutorial: <https://youtu.be/YdDvh5zPUWI>

RAF Low Flying Navigation: <https://youtu.be/NQWZEVaoFKQ>

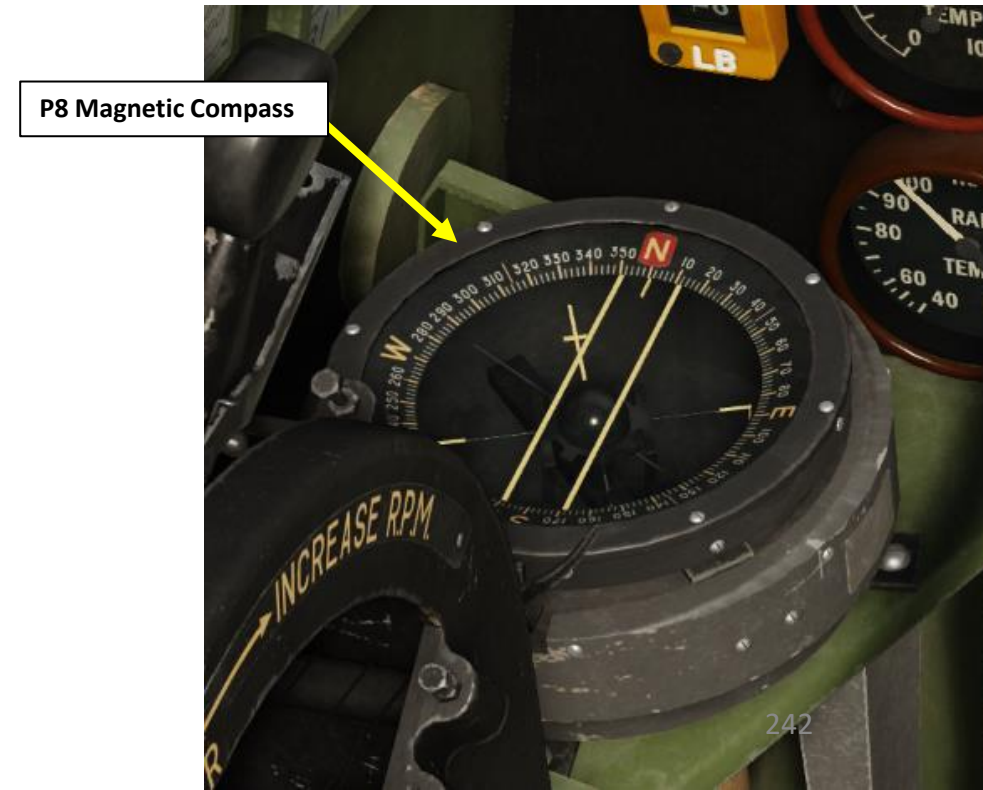
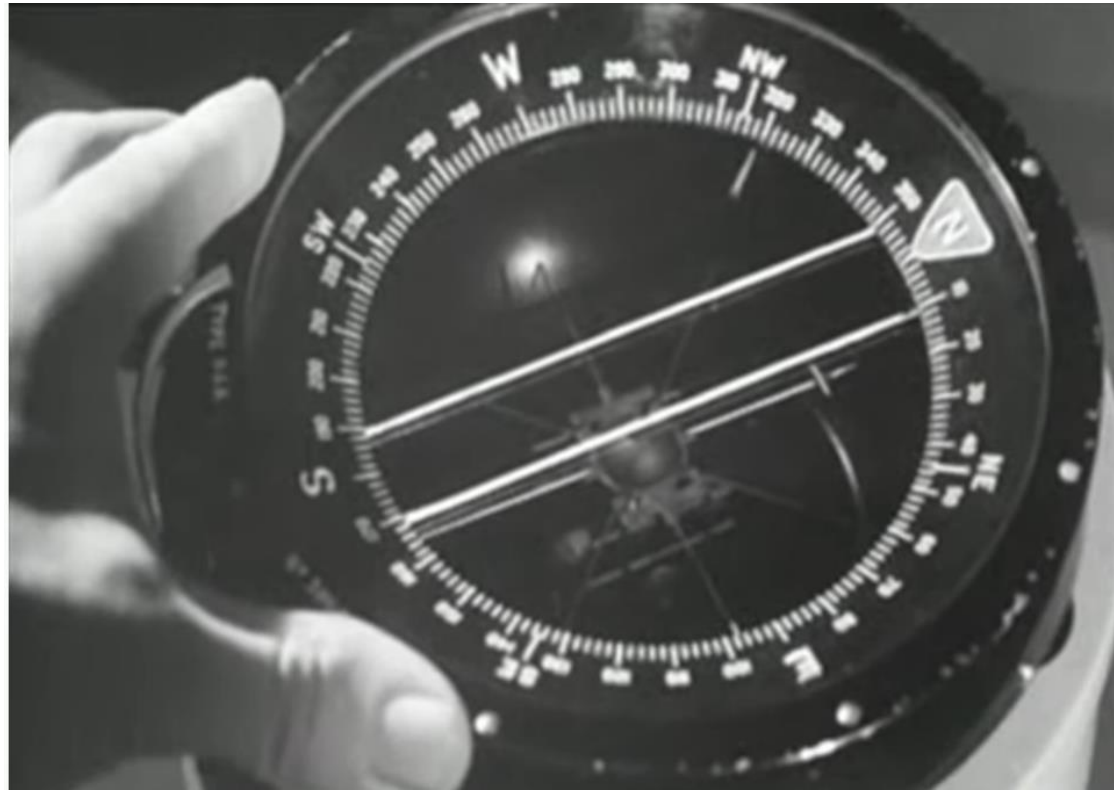
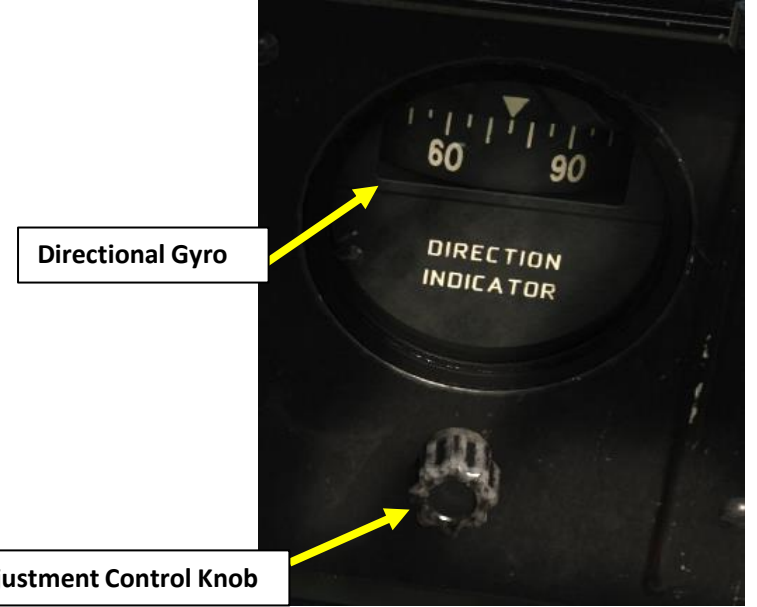

3 – P-8 MAGNETIC COMPASS

3.2 – Tutorial

1. Turn the Course Setter ring of the P-8 Magnetic Compass (scroll mousewheel on course setter ring) to align the red “N” (North Reference of the course setter) with the white “T” cross (real magnetic North of the compass).
2. The lubber line will display your current heading.
3. Turn the Directional Gyro adjustment knob to match the heading of the directional gyro with the one shown by the magnetic compass’ lubber line.
4. You may now use the Directional Gyro heading as a reference. You may need to re-align it with the magnetic compass after hard manoeuvres.

Note: High-G manoeuvres can decalibrate your gyro and give you a wrong reading. Be aware that once you start a dogfight, your gyro can give you readings that don't make sense. It's normal: it is one of the real-life drawbacks of this navigation system. The same issue is also recurrent in today's civilian acrobatic prop planes.

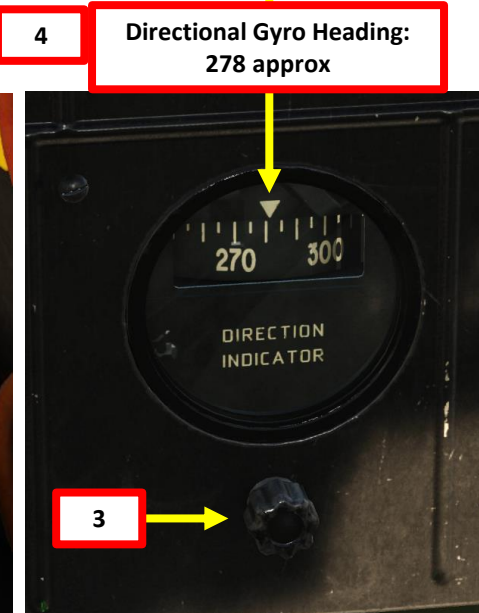
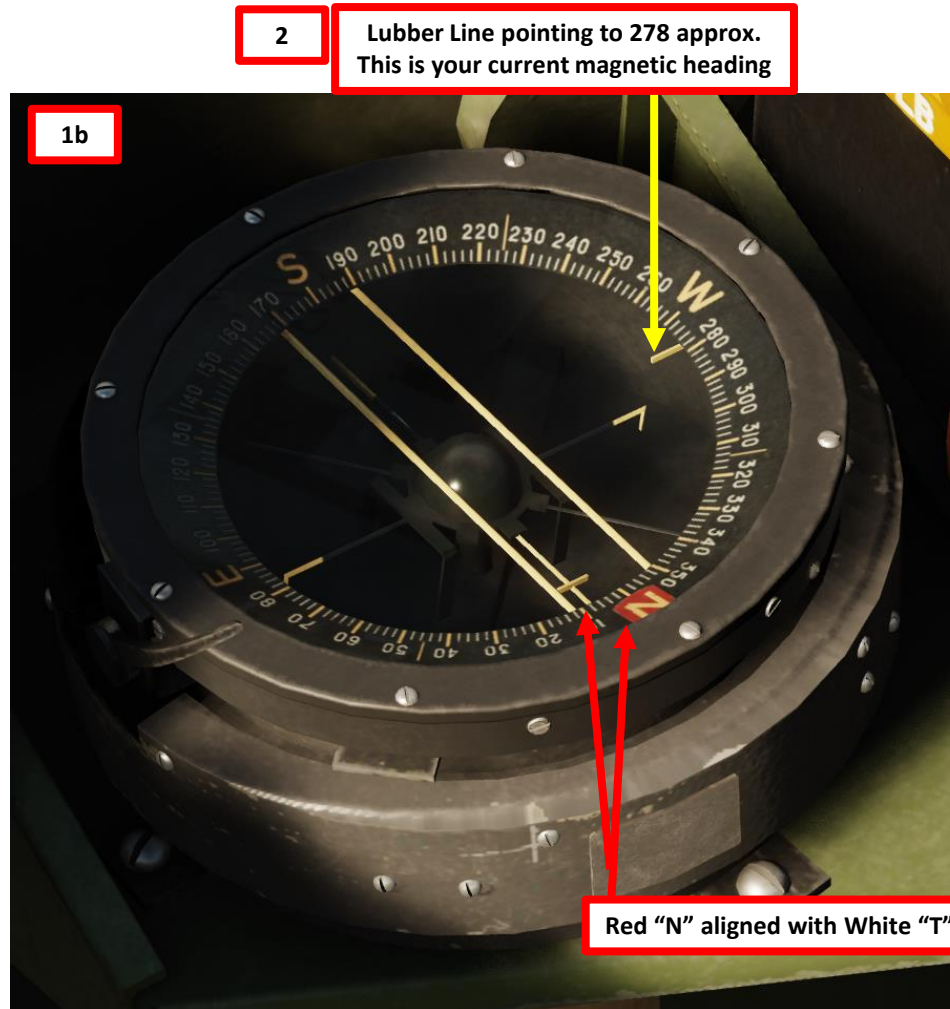
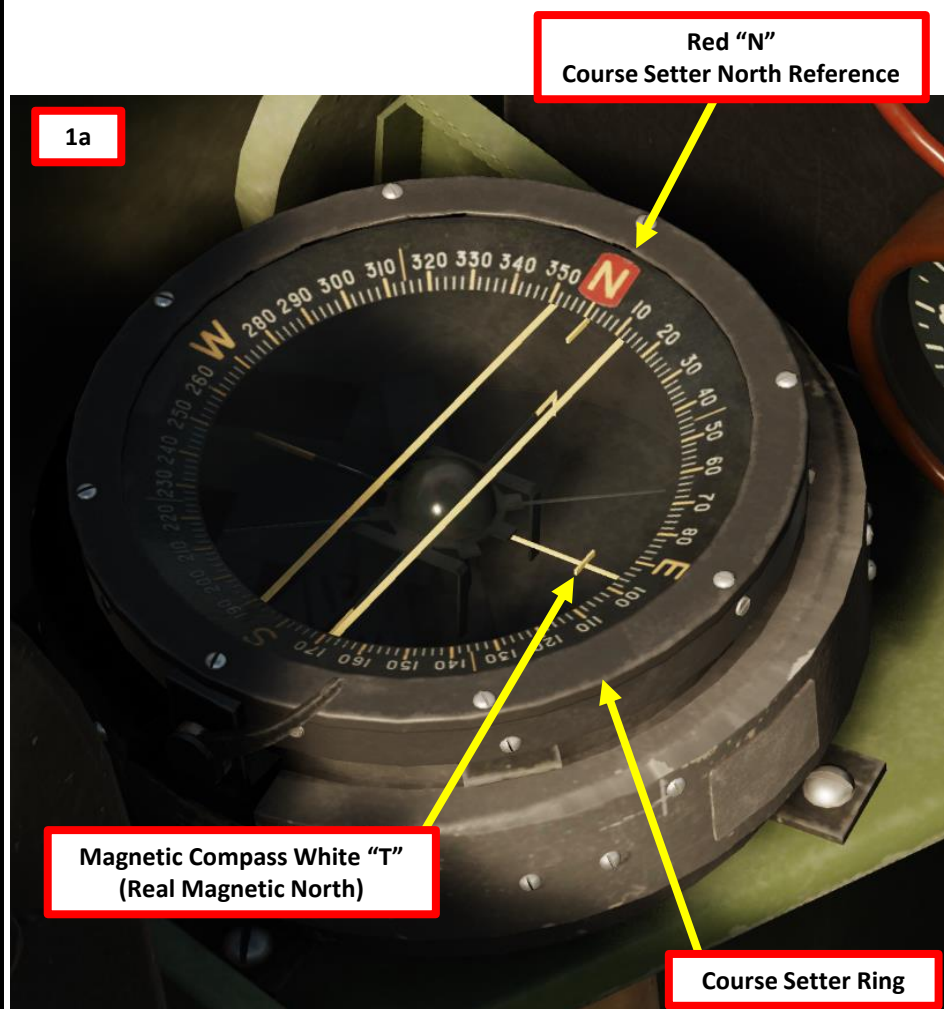

4 – REMOTE INDICATING (R.I.) COMPASS

The R.I. (Remote Indicating) Repeater Compass can be used to navigate just like the directional gyro. You can see this as a backup heading indicator to cross-check with the magnetic compass and directional gyro.

To use the R.I. Compass:

1. Set both Remote Indicating (R.I.) Compass Power Switches – ON (DOWN)
2. The aircraft heading is indicated on the R.I. Indicator.

Remote Indicating (R.I.)
Compass Power Switch

- UP: OFF
- DOWN: ON

1

Remote Indicating (R.I.) Compass Power
Switch

- UP: OFF
- DOWN: ON

1

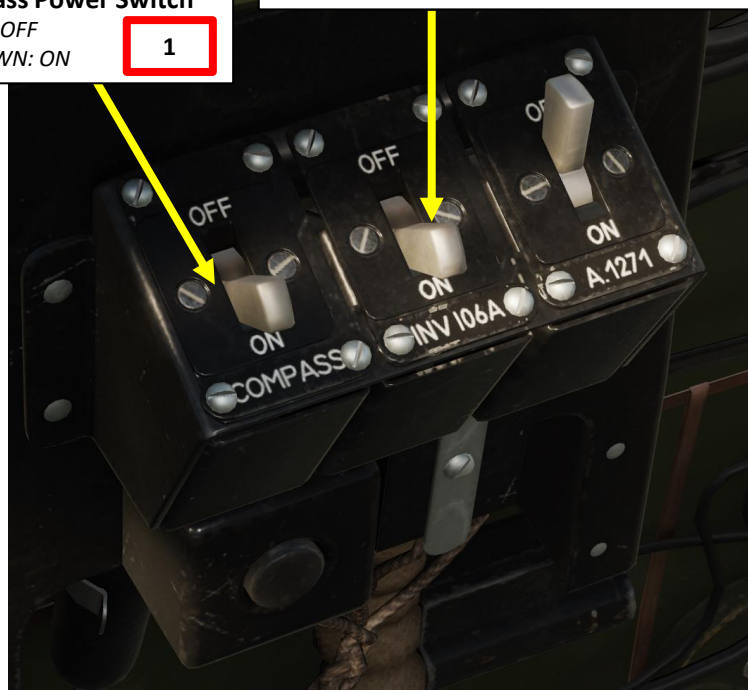

2 Magnetic Compass Remote Indicator
(Needle points towards current heading)

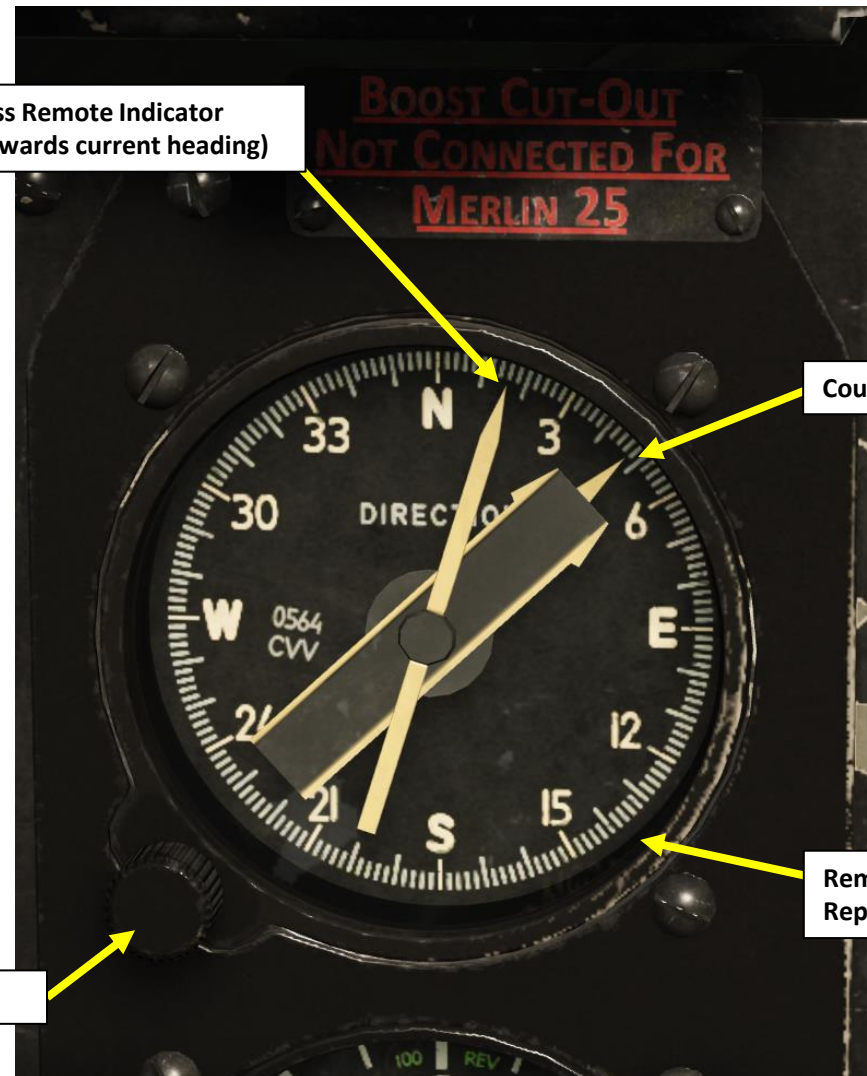

Course Setter Indicator

Remote Indicating (R.I.)
Repeater Compass

Course Setter Knob

5 – DIRECTION FINDING (D/F) SYSTEM

5.1 – Direction Finder System Components

The main component of the Direction Finder System is the Loop Antenna. The antenna can be rotated manually in order to pick up the direction of the signal source of a radio emitter.

Direction Finder (D/F) Deviation/Calibration Table Placard

- This table shows the actual known bearing of the radio emitter vs what the D/F loop antenna scale is telling you the bearing is (center column). The LEFT and RIGHT columns of the table indicate whether the bearing of the radio source is to your left or to your right.

Left	Direction Finder Scale Reference Value	Right
27	20	22.5
47	40	43
67	60	64
87	80	85
110	110	107.5
131	120	120

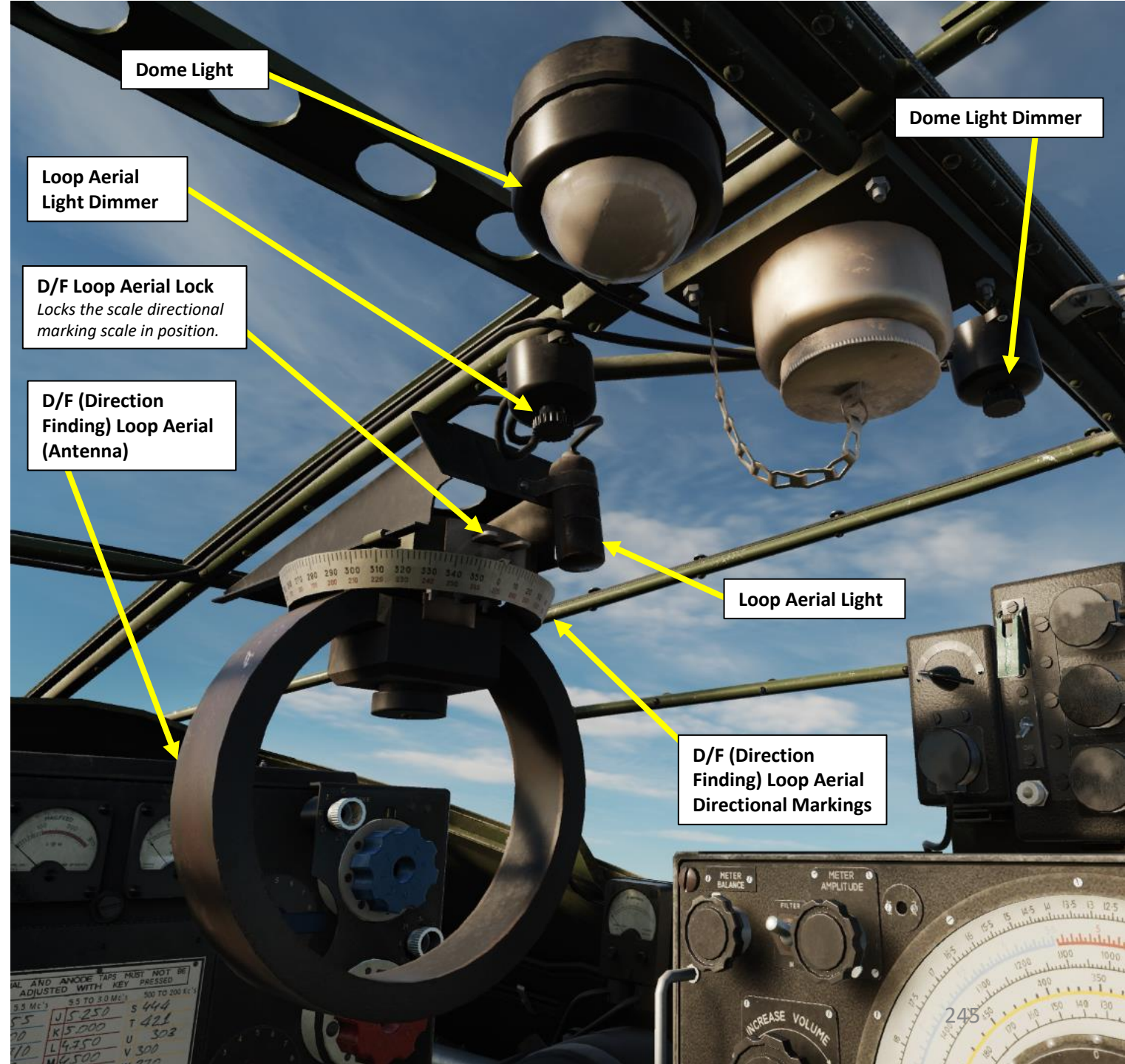
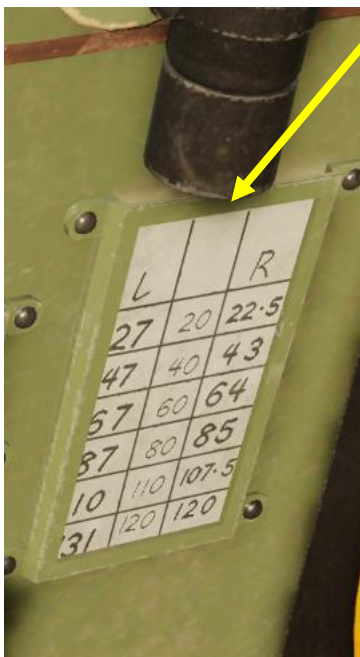

Dome Light

Dome Light Dimmer

Loop Aerial Light Dimmer

D/F Loop Aerial Lock
Locks the scale directional marking scale in position.

D/F (Direction Finding) Loop Aerial (Antenna)

Loop Aerial Light

D/F (Direction Finding) Loop Aerial Directional Markings

AL AND ANODE TAPS MUST NOT BE ADJUSTED WITH KEY PRESSED

5.5 Mc. 55 TO 80 Mc. 500 TO 200 Kc.

55 J 5 250 S 444
60 K 5 000 T 421
70 L 4 350 U 302
80 M 2 500 V 300



5 – DIRECTION FINDING (D/F) SYSTEM

5.1 – Direction Finder System Components

Direction Finding can be performed by either:

- Using the Direction Finding Visual Indicator or;
- Turning the D/F Loop Aerial and using the change in sound signal volume to determine the direction to a signal source.

The Direction Finder works with the T1154 Radio Transmitter and R1155 Radio Receiver, which both need to be powered on.

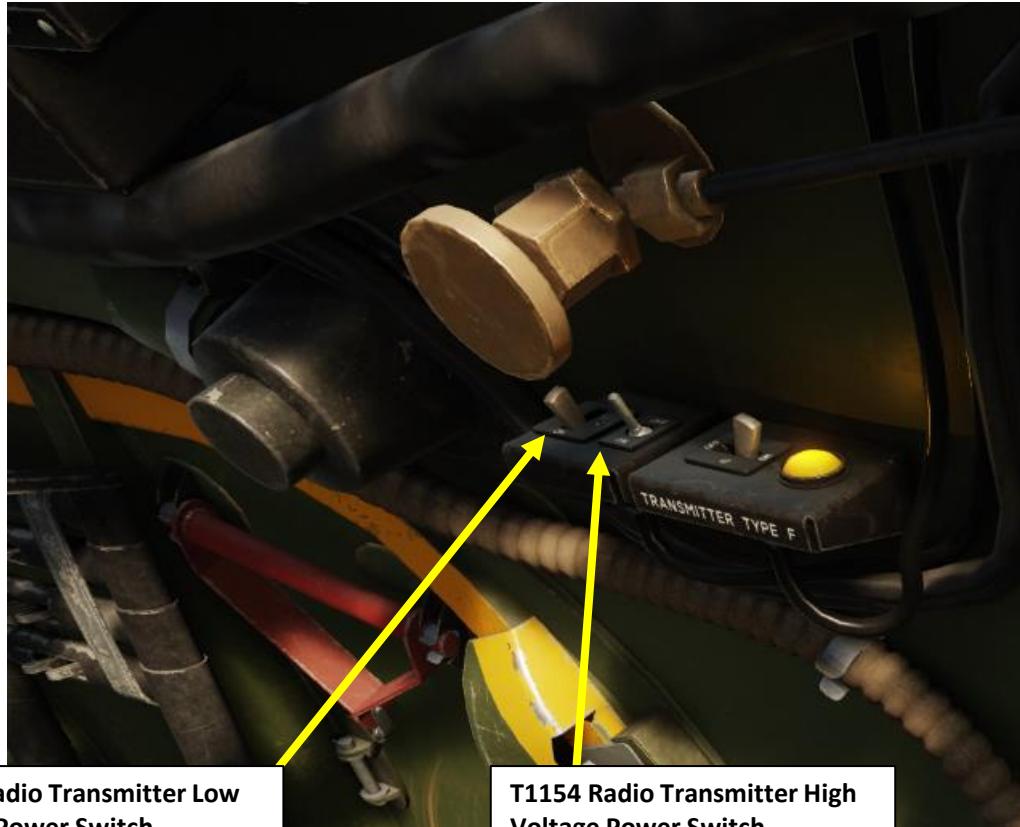

T1154 Radio Transmitter Low Voltage Power Switch

- Right: OFF
- Left: ON

T1154 Radio Transmitter High Voltage Power Switch

- Right: OFF
- Left: ON

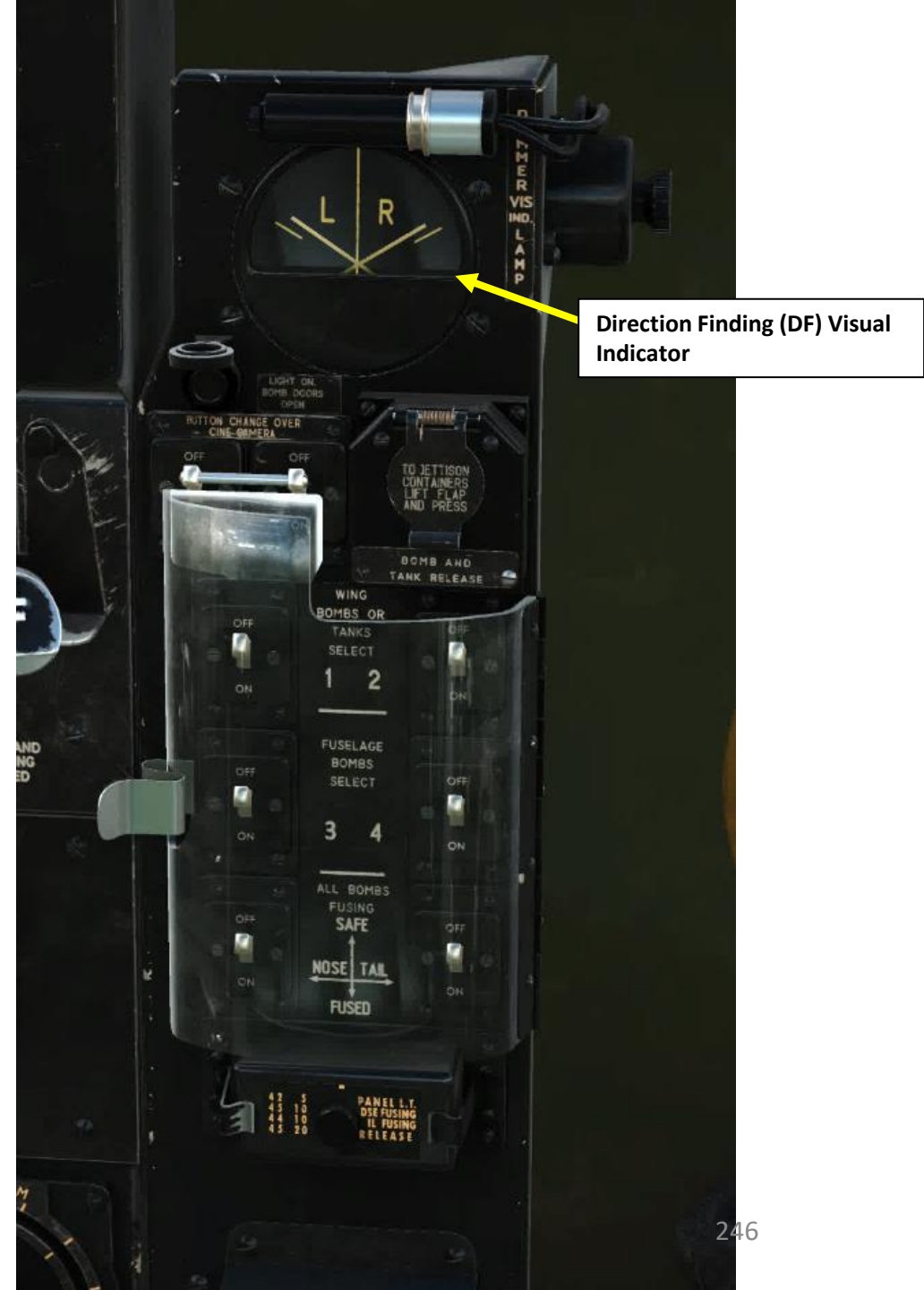

Direction Finding (DF) Visual Indicator

5 – DIRECTION FINDING (D/F) SYSTEM

5.1 – Direction Finder System Components

The T1154 Radio Transmitter Set Tuning Control needs to be set to STD-BI (Standby) in order to tune the R1155 radio receiver to the signal you want to track.

The Aerial Mode Selector must be set to DF (Direction Finder), which will prevent you from communicating on the radio, but it will allow you to use D/F functions of the radio sets.

Aerial Mode Selector

- *DF: Direction Finder*
- *MF ON FIXED: Allows transmission/reception of Medium Frequency on fixed antenna. Used if trailing antenna is defective.*
- *NORMAL: Normal Operation, used when fixed antenna and trailing antenna are both serviceable.*
- *HF ON TRAILING: Allows transmission/reception of High Frequency on trailing antenna. Used if fixed antenna is defective.*
- *EARTH: Both fixed and trailing antennas are “earthed” (grounded). Use during conditions of heavy static electricity in the air.*

T1154 Radio Transmitter Set

T1154 Radio Transmitter Set Tuning Control (S5)

- **OFF:** Off
- **STD-BI:** Standby, receiver becomes operative.
- **TUNE:** low power continuous wave (CW) transmission occurs. Short distance communications and any setting up adjustments of the transmitter should be made with the switch at this position.
- **CW:** Continuous Wave. L.T. (Low Tension) energizing circuits of the two power units are maintained so that H.T. (High Tension) and L.T. continue to be supplied to transmitter and receiver.
- **MCW:** Modulated Continuous Wave. When key is pressed, oscillations from the tone-generator are fed to the suppressor grids of the power amplifiers, thus modulating their output at low frequency.
- **R/T:** Radio/Telephony. In this position, pressing the “T1154 Radio Morse Key” transmits navigator voice.

Notes:

- HF (High Frequency) transmission/reception is done with the fixed aerial (antenna). Frequency ranges 1 (blue) and 2 (red) are on HF frequencies.
- MF (Medium Frequency) transmission/reception is done with the trailing aerial (antenna). Frequency range 3 (yellow) is on MF frequencies.

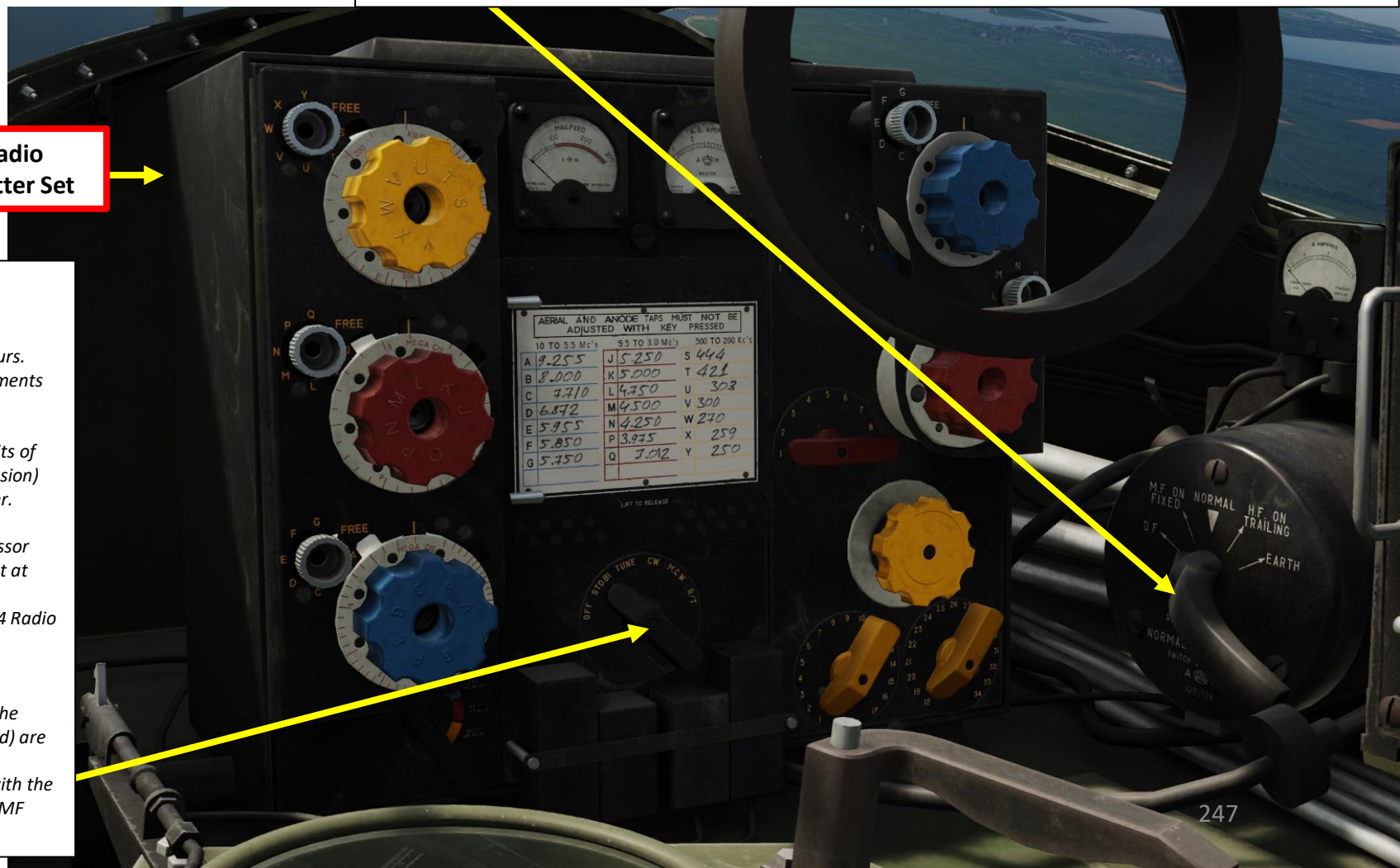

5 – DIRECTION FINDING (D/F) SYSTEM

5.1 – Direction Finder System Components

The R1155 Radio receiver is the primary tool to set the frequency of the radio signal (or navigation aid signal) that you want to track.

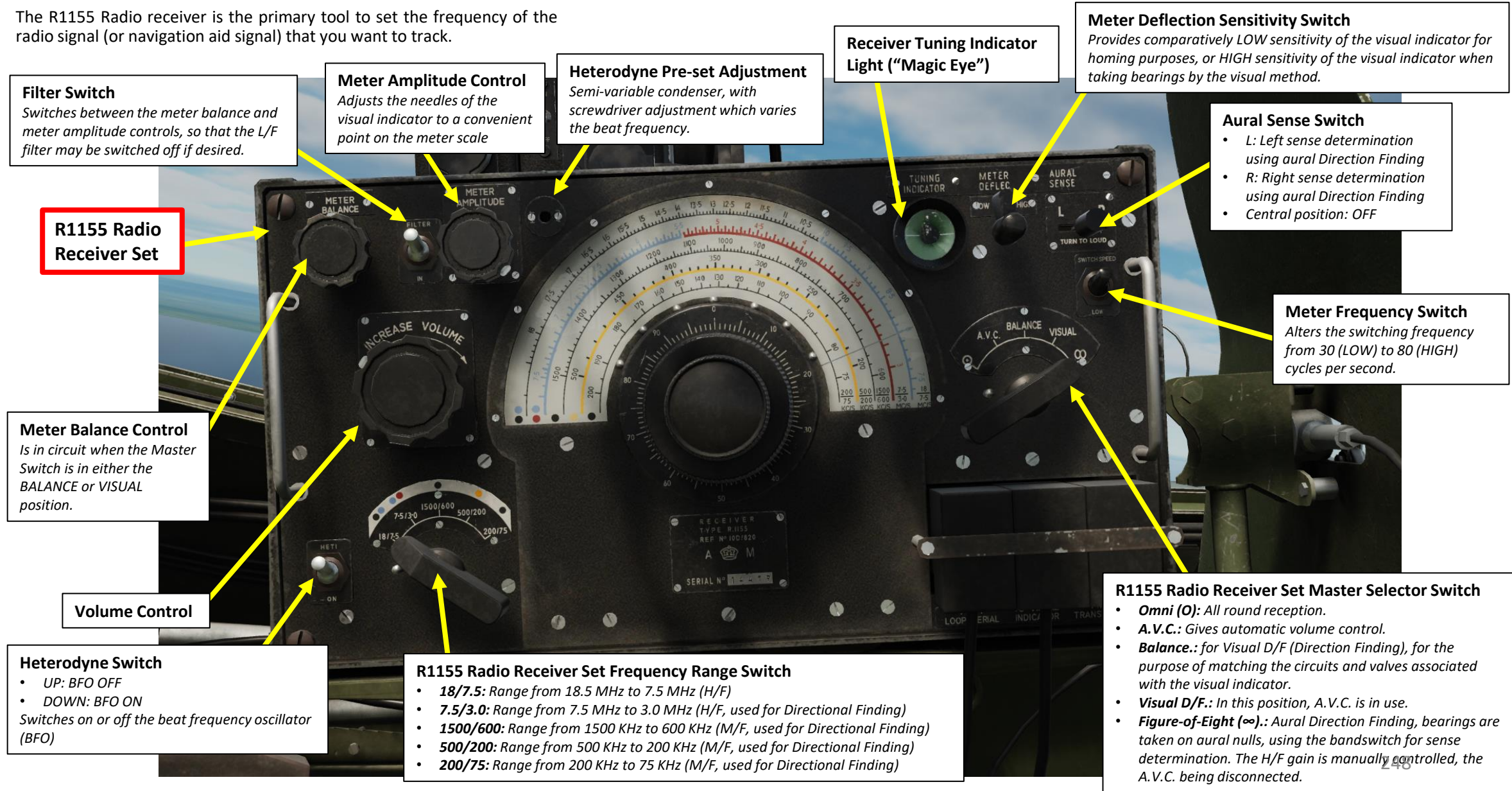

Filter Switch
Switches between the meter balance and meter amplitude controls, so that the L/F filter may be switched off if desired.

Meter Amplitude Control
Adjusts the needles of the visual indicator to a convenient point on the meter scale

Heterodyne Pre-set Adjustment
Semi-variable condenser, with screwdriver adjustment which varies the beat frequency.

Receiver Tuning Indicator Light ("Magic Eye")

Meter Deflection Sensitivity Switch
Provides comparatively LOW sensitivity of the visual indicator for homing purposes, or HIGH sensitivity of the visual indicator when taking bearings by the visual method.

Aural Sense Switch

- L: Left sense determination using aural Direction Finding
- R: Right sense determination using aural Direction Finding
- Central position: OFF

R1155 Radio Receiver Set

Meter Frequency Switch
Alters the switching frequency from 30 (LOW) to 80 (HIGH) cycles per second.

Meter Balance Control
Is in circuit when the Master Switch is in either the BALANCE or VISUAL position.

Volume Control

R1155 Radio Receiver Set Master Selector Switch

- **Omni (O):** All round reception.
- **A.V.C.:** Gives automatic volume control.
- **Balance.:** for Visual D/F (Direction Finding), for the purpose of matching the circuits and valves associated with the visual indicator.
- **Visual D/F.:** In this position, A.V.C. is in use.
- **Figure-of-Eight (∞):** Aural Direction Finding, bearings are taken on aural nulls, using the bandswitch for sense determination. The H/F gain is manually controlled, the A.V.C. being disconnected.

Heterodyne Switch

- UP: BFO OFF
- DOWN: BFO ON

Switches on or off the beat frequency oscillator (BFO)

R1155 Radio Receiver Set Frequency Range Switch

- **18/7.5:** Range from 18.5 MHz to 7.5 MHz (H/F)
- **7.5/3.0:** Range from 7.5 MHz to 3.0 MHz (H/F, used for Directional Finding)
- **1500/600:** Range from 1500 KHz to 600 KHz (M/F, used for Directional Finding)
- **500/200:** Range from 500 KHz to 200 KHz (M/F, used for Directional Finding)
- **200/75:** Range from 200 KHz to 75 KHz (M/F, used for Directional Finding)

5 – DIRECTION FINDING (D/F) SYSTEM

5.2 – Radio Emitter Setup

The Mosquito's radio system can home on the transmission emitter. In this case, we will simulate a radio broadcast from a beacon installed next to a Willys Jeep. We will first need to set up a mission with a unit that transmits a beacon signal on a **HF AM frequency of 8 MHz**. This is the frequency we will use for tutorials 5.3 and 5.4.

1. Create Unit that will transmit the distress signal
2. In **ADVANCED (WAYPOINT ACTIONS)** of Waypoint 0
 - I. Click on **ADD**
 - a) Select Type - **PERFORM COMMAND**
 - b) Select **ACTION – SET FREQUENCY**
 - c) Set Frequency to a valid frequency (8 MHz)
 - d) Select **AM Band**
 - e) Select Power (i.e. 1000 W)
 - II. Click on **ADD**
 - a) Select Type - **PERFORM COMMAND**
 - b) Select **ACTION – TRANSMIT MESSAGE**
 - c) Select a valid .wav or .ogg audio file with the distress call. Add subtitles if desired.
 - d) Select **LOOP**

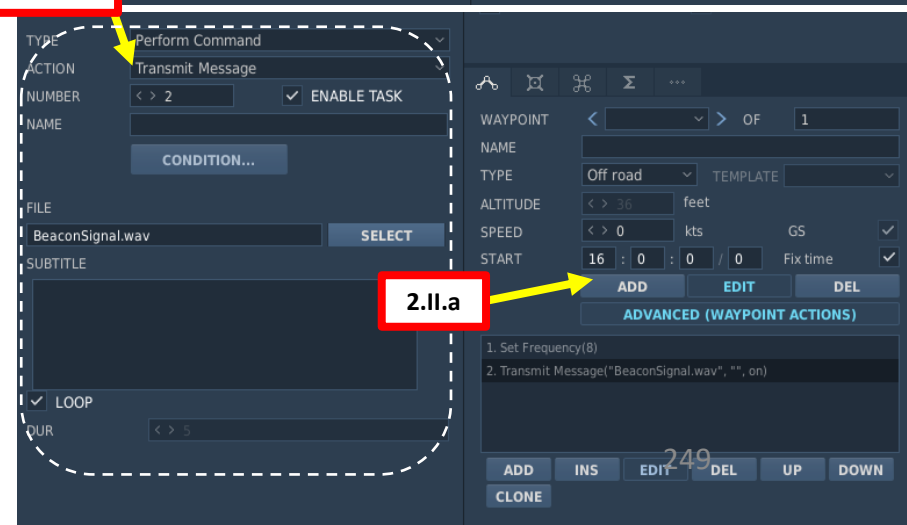
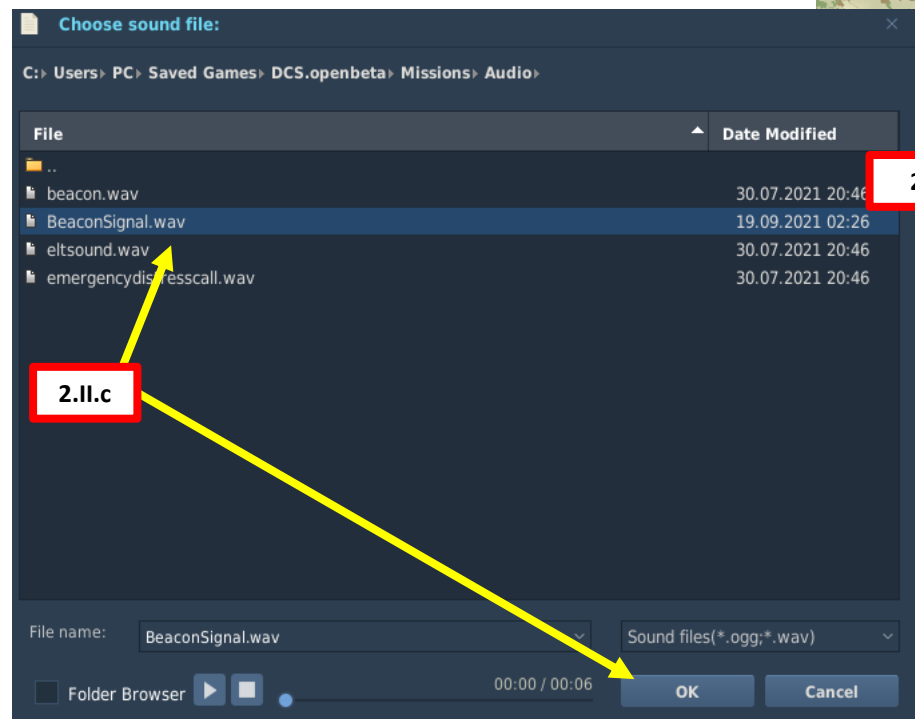
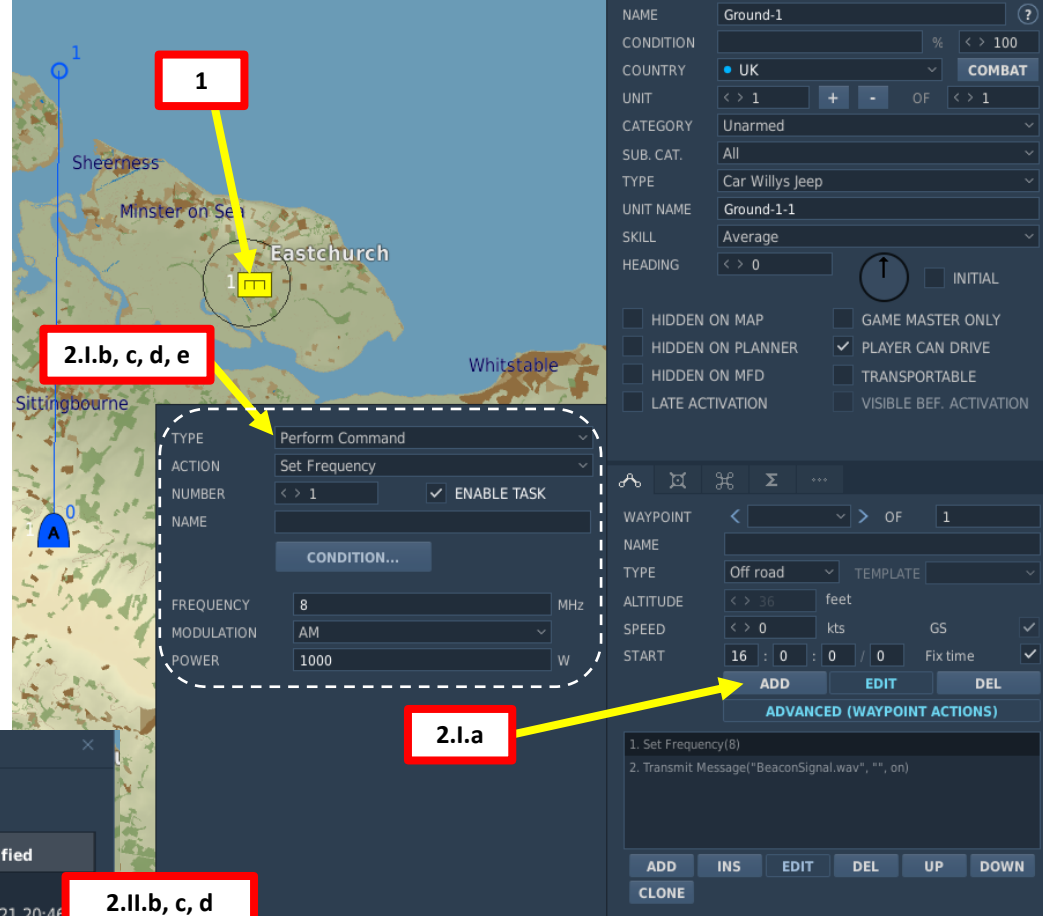

5 – DIRECTION FINDING (D/F) SYSTEM

5.3 – Aural D/F Tutorial

The principle of aural radio direction finding is that the reception strength of a radio signal changes based on the orientation of the loop antenna.

Using the “Aural” mode allows you to get a general idea of where the radio waves come from. As you change the orientation of the loop antenna, the volume of the radio signal will either increase or decrease. Using the heading scale, the navigator can then tell the pilot where to go to track the source of the radio waves.

If a loop antenna is placed with its plane perpendicular to the travel direction of a radio wave, the signal reception is minimal (signal volume decreases).

If a loop antenna is placed parallel to the travel direction of a radio wave, the signal reception is maximal (signal volume increases).

The overall idea of the Aural D/F is to tune the R1155 radio receiver to the frequency of the emitter, listen for a signal (in our case, the beacon broadcasts a morse code) then turn the loop antenna until you can't hear the signal anymore, placing the loop antenna perpendicular to the radio waves. Then, you read the bearing scale of the antenna to determine the bearing of the emitter relative to the aircraft.

Here is a good example of the effect of loop antenna orientation:
https://youtu.be/3S_Xrqqu7iA

Note: The D/F system can home on any radio emitter within valid frequency ranges, including non-directional beacons (NDBs).



Example 1



Example 2

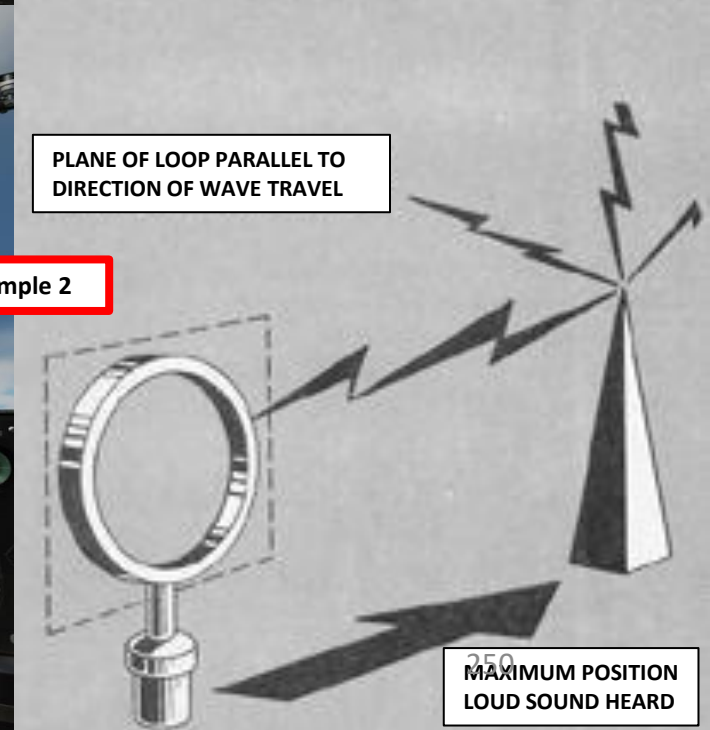
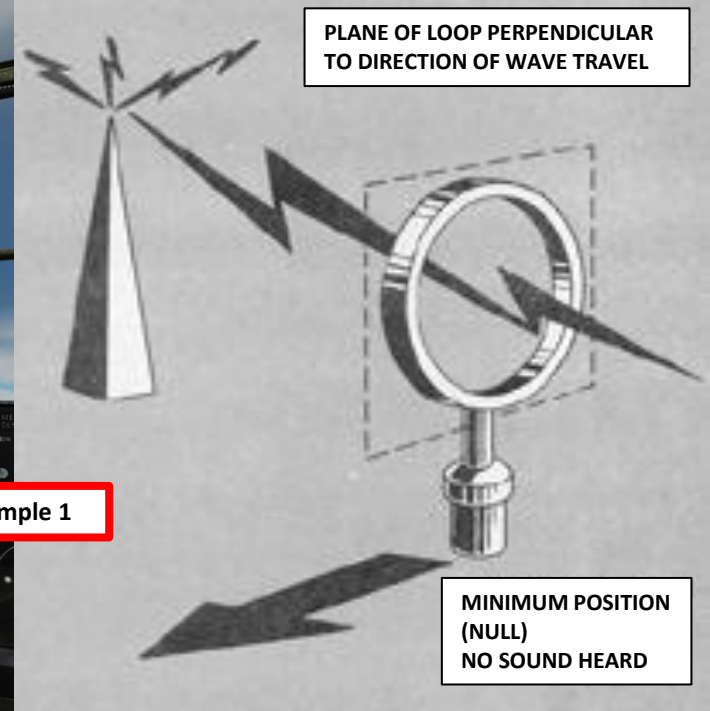

5 – DIRECTION FINDING (D/F) SYSTEM

5.3 – Aural D/F Tutorial

1. Select the Navigator Seat by pressing “2”.
2. Set T1154 Radio Transmitter Low Voltage Power Switch – ON (LEFT)
3. Set T1154 Radio Transmitter High Voltage Power Switch – ON (LEFT)
4. Lower the armored headrest of the navigator seat to access the radio compartment by clicking on the headrest handle.
5. Set T1154 Radio Transmitter Set Tuning Control knob to STD-BI (Standby) position.
6. Set Aerial (Antenna) Mode Selector – DF (Direction Finder)

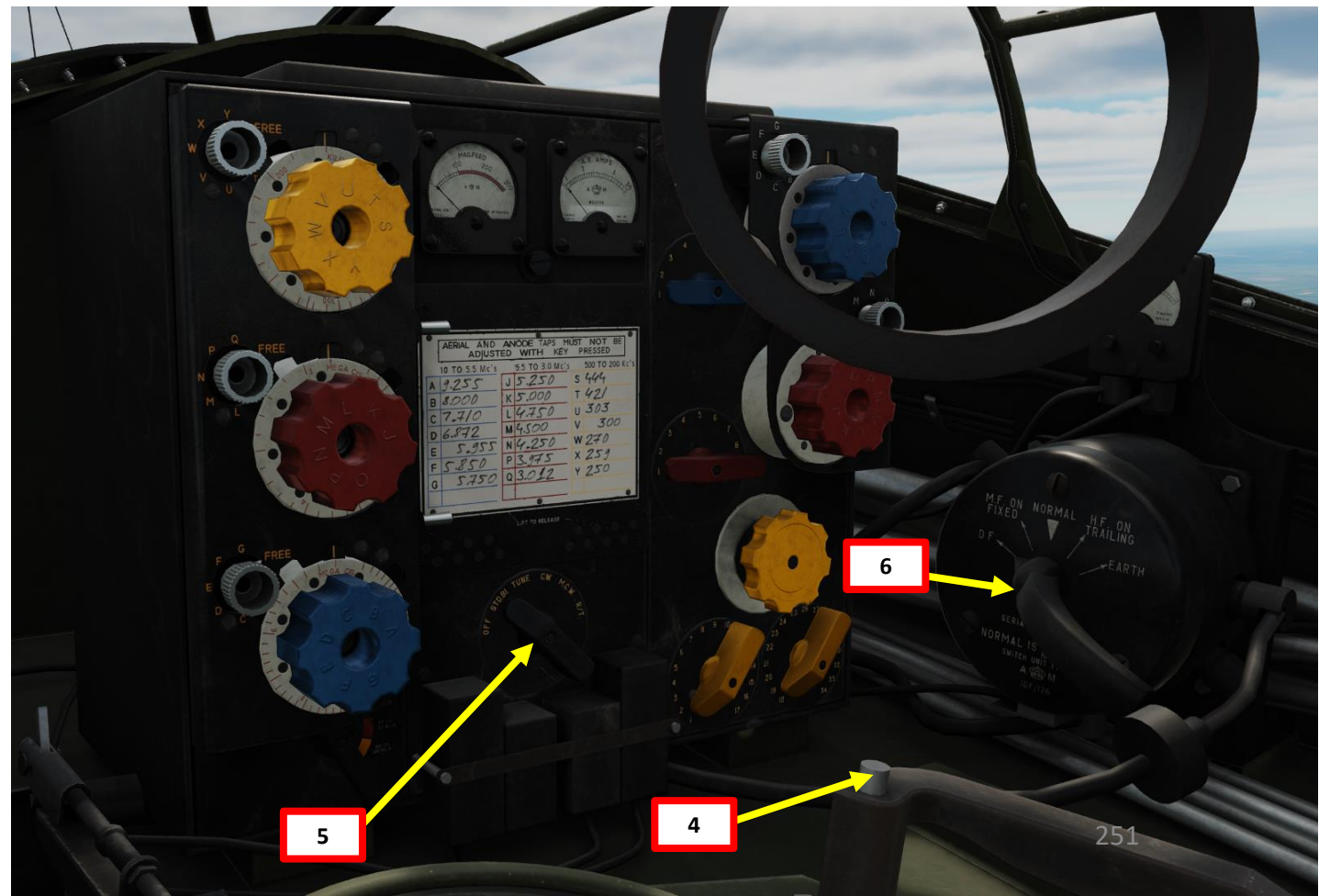
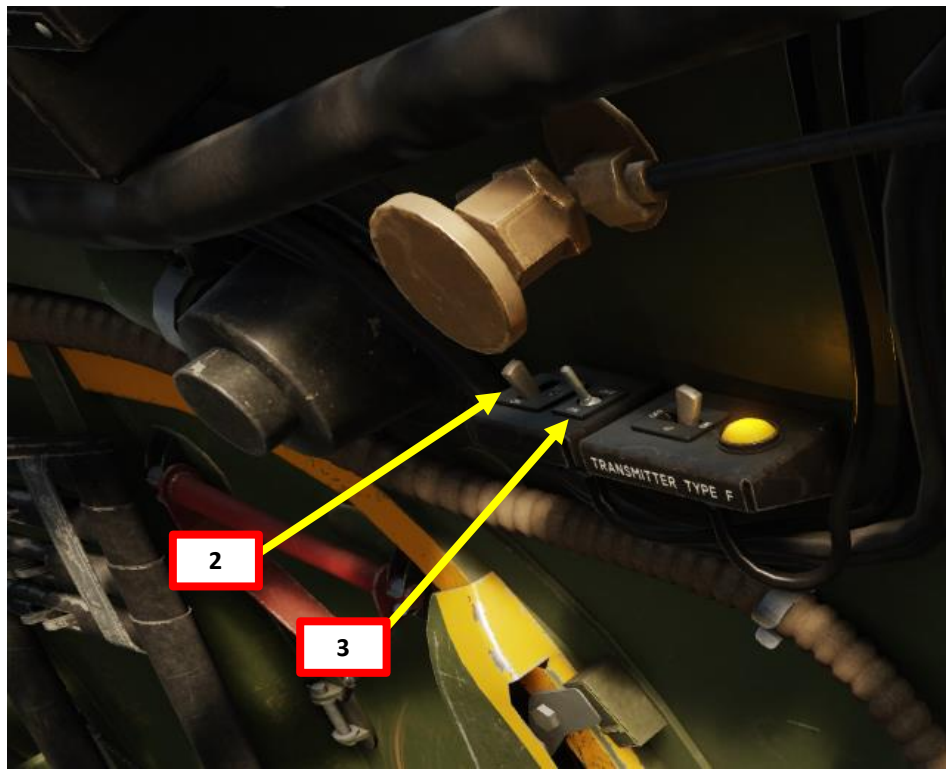

5 – DIRECTION FINDING (D/F) SYSTEM

5.3 – Aural D/F Tutorial

7. Set R1155 Radio Receiver Set Master Selector Switch – Figure-of-Eight (∞)
8. Confirm that the Tuning Indicator Light illuminates
9. Set the R1155 Radio Receiver Set Frequency Range Switch to the appropriate frequency range (“18/7.5” for frequency 8 MHz).
10. Use tuning knobs to set radio frequency needle to the appropriate frequency (8 MHz). Since we use the 18/7.5 frequency range, we use the outermost band.
 - Use the outer tuning knob for coarse tuning (big needle movements) and the inner tuning knob for fine tuning (small needle movements).
11. Adjust Volume Control.

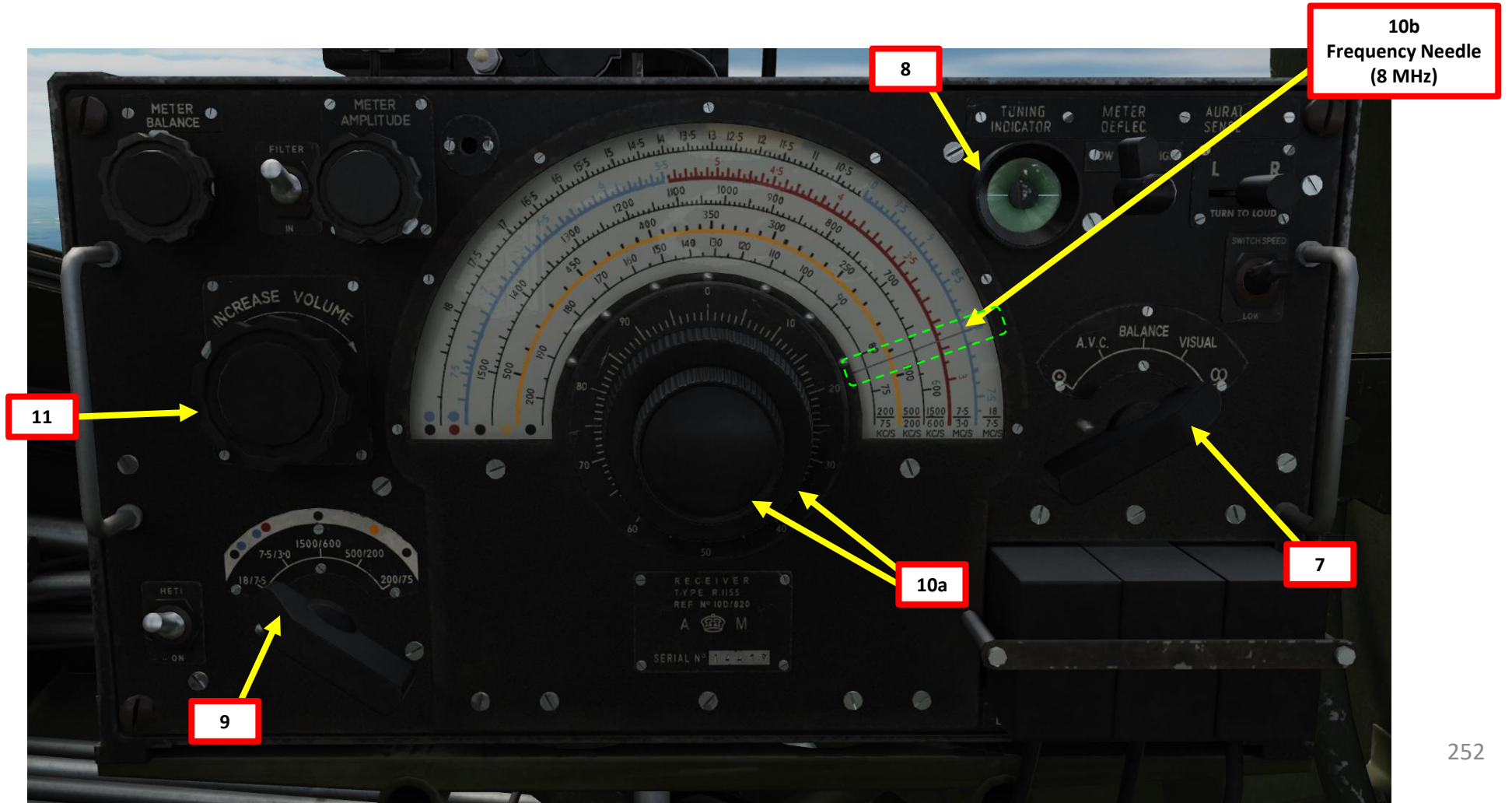

5 – DIRECTION FINDING (D/F) SYSTEM

5.3 – Aural D/F Tutorial

12. Confirm that you hear the morse code signal of the radio emitter.
13. In this example, we are currently flying at a heading of 005.
14. Unlock the Loop Antenna
15. The upper black scale markings on the loop antenna represent the orientation of the antenna using the aircraft as a reference.
 - "0" points in front of you
 - "090" points to your right
 - "180" points behind you
 - "270" points to your left.
16. We will turn the loop antenna and use the strength (volume) of the morse code signal audible through your headset to figure out where the radio emitter is transmitting from relative to your aircraft. Left click and drag mouse over the Loop Antenna Scale.

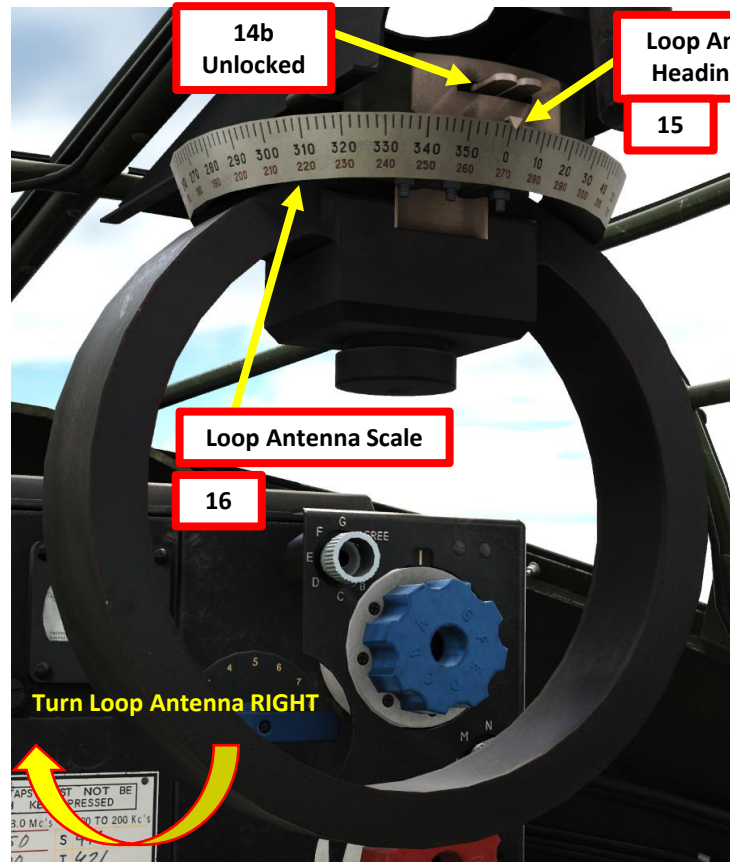
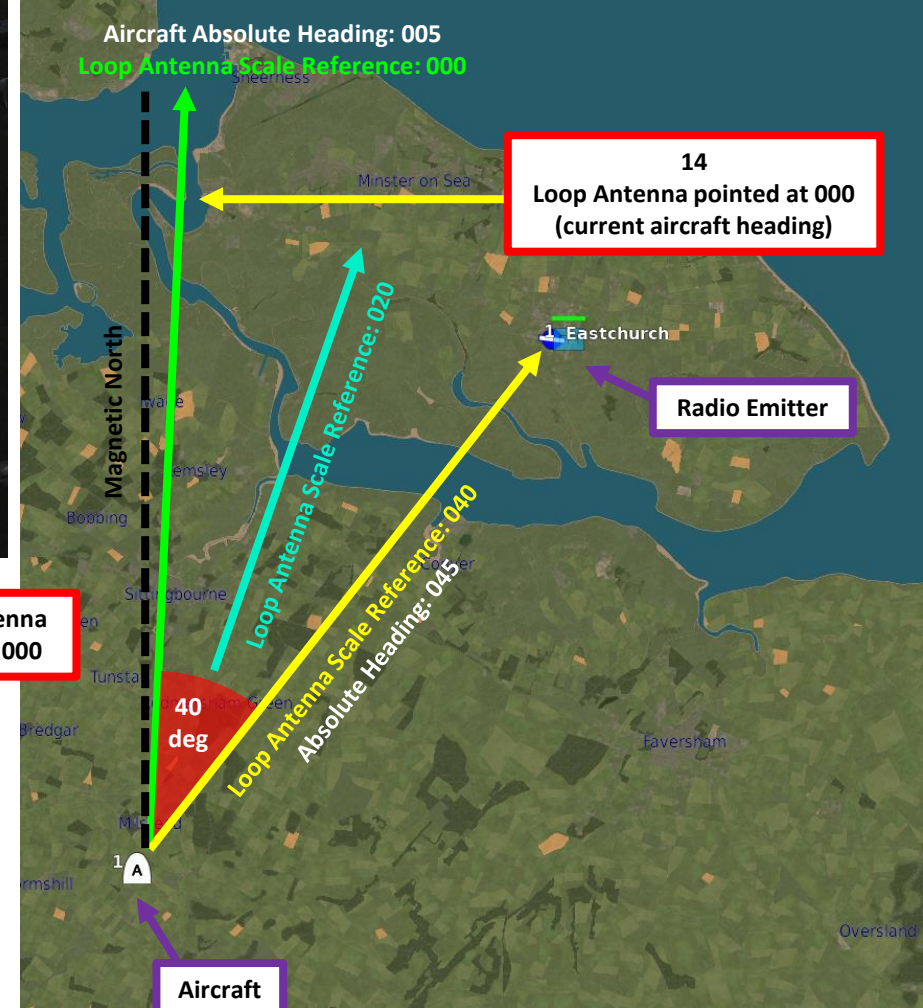
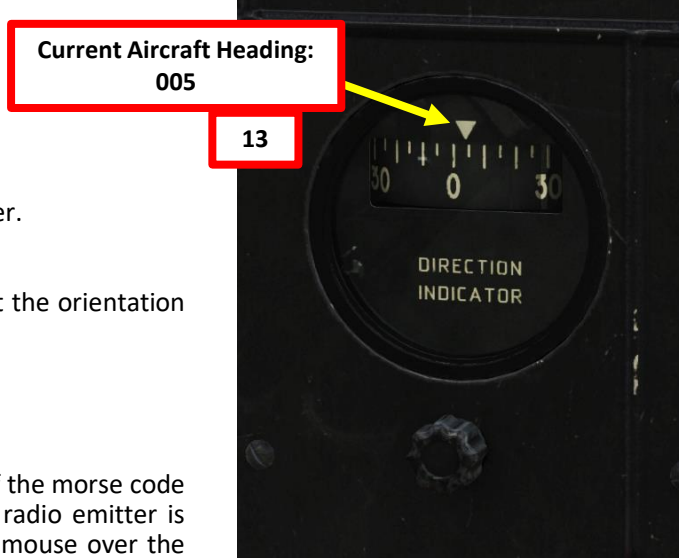

5 – DIRECTION FINDING (D/F) SYSTEM

5.3 – Aural D/F Tutorial

17. Turn the loop antenna until the volume of the morse code signal becomes faint (low signal strength). This means that the plane of the antenna is close to perpendicular to the direction of the radio wave travel. In this example, we turn the loop antenna from a position of "000" to "020".
18. Set the Aural Sense Switch LEFT. If the morse code signal is still audible, it means you have to turn the loop antenna further left relative to the aircraft heading. If the morse signal is not audible, set the Aural Sense Switch RIGHT.
19. In this example, when loop antenna points towards 020, the morse signal is not audible with the Aural Sense Switch LEFT, but the morse signal is still audible with Aural Sense Switch RIGHT.
20. Turn the loop antenna RIGHT in increments of about 10 deg, then perform the Aural Sense Switch LEFT & RIGHT checks of steps 18) and 19) again.
21. When the Aural Sense Switch is set to either LEFT, NEUTRAL or RIGHT and the morse code signal is not audible (null) anymore, the loop antenna is pointing towards the radio source emitter.



Loop Antenna at 020
Switch Neutral
No Sound Audible (Null) 18a



Loop Antenna at 020
Switch LEFT
No Sound Audible (Null)
No need to turn antenna LEFT 18b



Loop Antenna at 020
Switch RIGHT
Morse Code Signal Audible
Need to turn antenna further RIGHT 18c

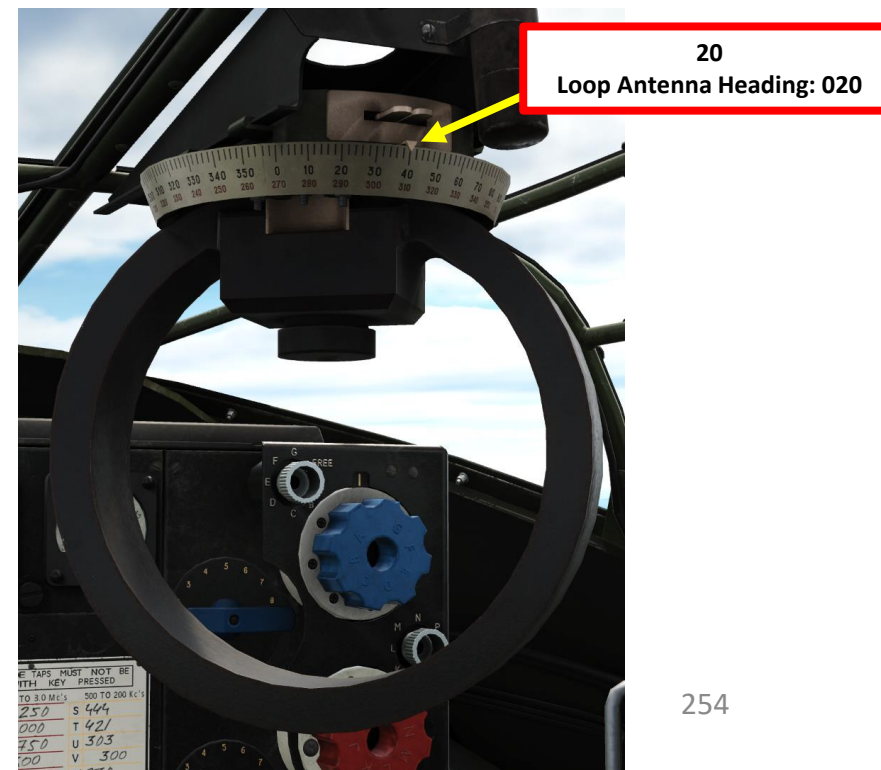
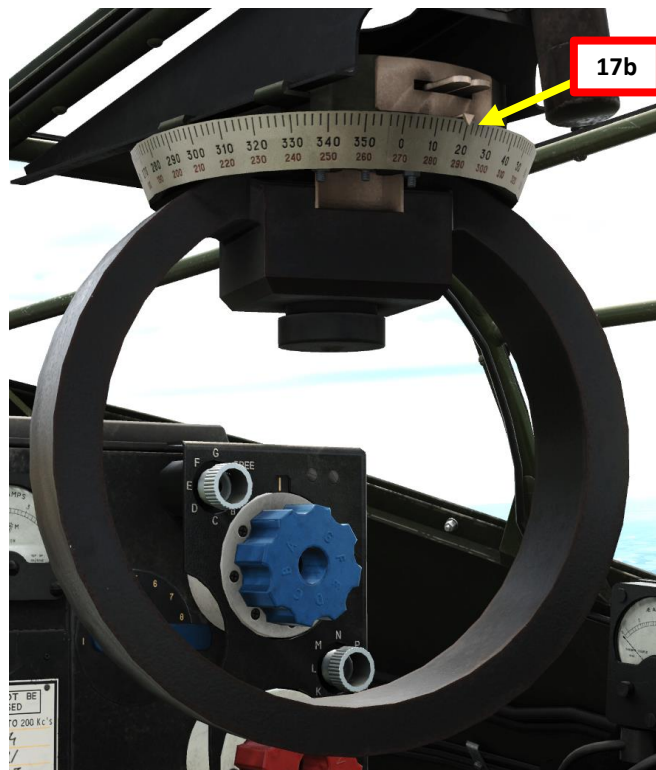
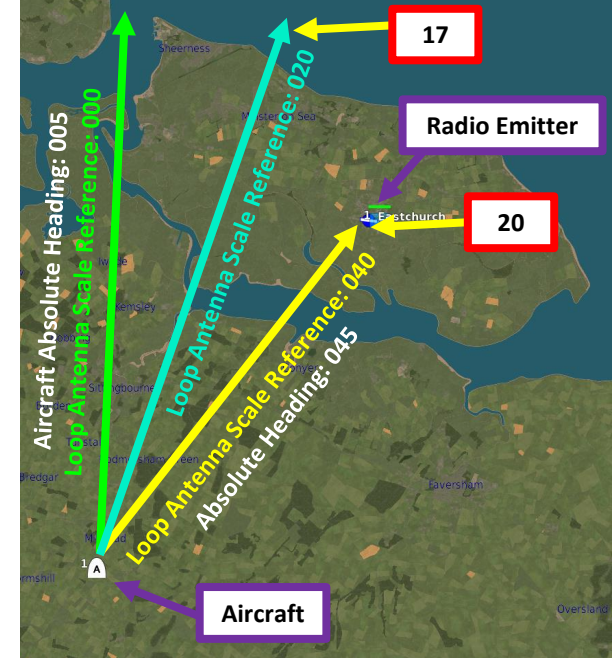

5 – DIRECTION FINDING (D/F) SYSTEM

5.3 – Aural D/F Tutorial

22. In this example, we found out that the radio emitter is at a heading of “040” relative to the aircraft; we turned the loop antenna to “040”, then the sound signal went from faint to inaudible (null). Therefore, you have to steer 40 degrees to the RIGHT in order to head towards the radio source.

Here is a good example by Reflected Simulations: <https://youtu.be/tGXSLKSiRk?t=400>



Loop Antenna at 040
Switch Neutral
No Sound Audible

22b



Loop Antenna at 040
Switch LEFT
No Sound Audible
No need to turn antenna LEFT

22c



Loop Antenna at 040
Switch RIGHT
No Sound Audible
No need to turn antenna RIGHT

22d



Current Aircraft Heading:
005



22a
Loop Antenna Heading: 020

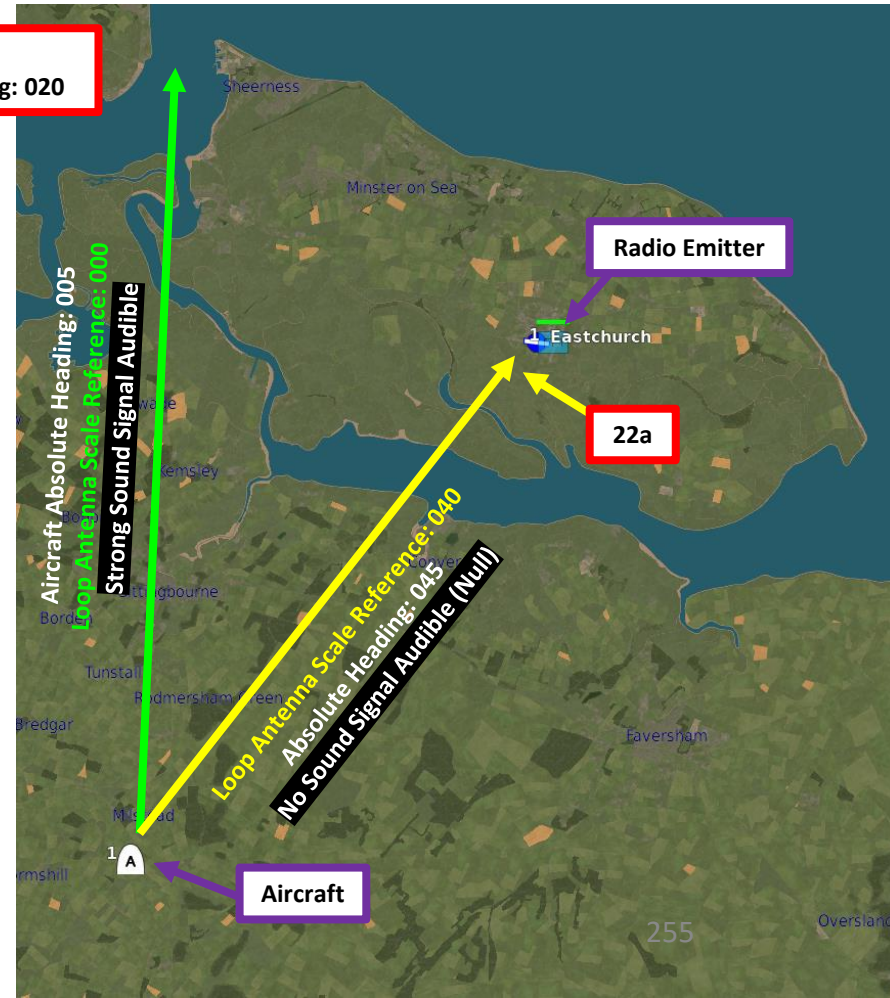

Aircraft Absolute Heading: 005
Loop Antenna Scale Reference: 040
Strong Sound Signal Audible

Loop Antenna Scale Reference: 040
Absolute Heading: 045
No Sound Signal Audible (Null)

Radio Emitter

22a

Aircraft

5 – DIRECTION FINDING (D/F) SYSTEM

5.4 – Visual D/F Tutorial

1. Select the Navigator Seat by pressing “2”.
2. Set T1154 Radio Transmitter Low Voltage Power Switch – ON (LEFT)
3. Set T1154 Radio Transmitter High Voltage Power Switch – ON (LEFT)
4. Lower the armored headrest of the navigator seat to access the radio compartment by clicking on the headrest handle.
5. Set T1154 Radio Transmitter Set Tuning Control knob to STD-BI (Standby) position.
6. Set Aerial (Antenna) Mode Selector – DF (Direction Finder)

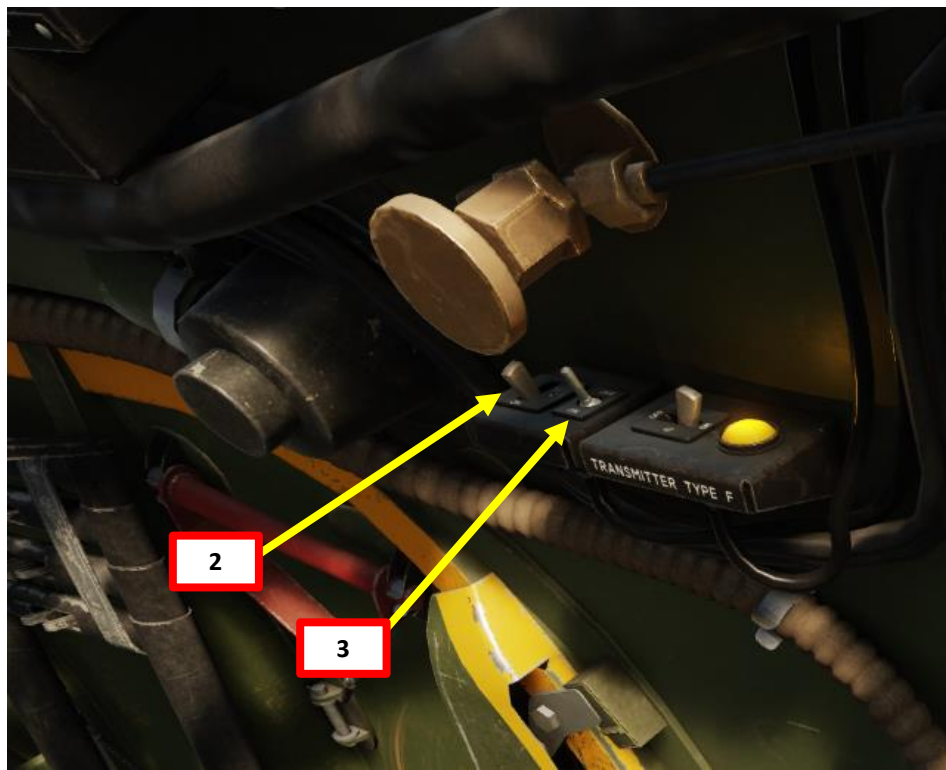

Visual Direction Finding uses a visual indicator to provide steering cues to track a radio signal source. While it is easier to use than turning the loop antenna and use the “aural” method, you should already be heading in roughly the correct direction.

In practice, you would first use the aural method to make sure the aircraft is flying towards the radio emitter. Once you are roughly on course, then you would switch to the visual method to make smaller steering adjustments.

Here is an example of visual direction finding: https://youtu.be/POyFjwUZg_c

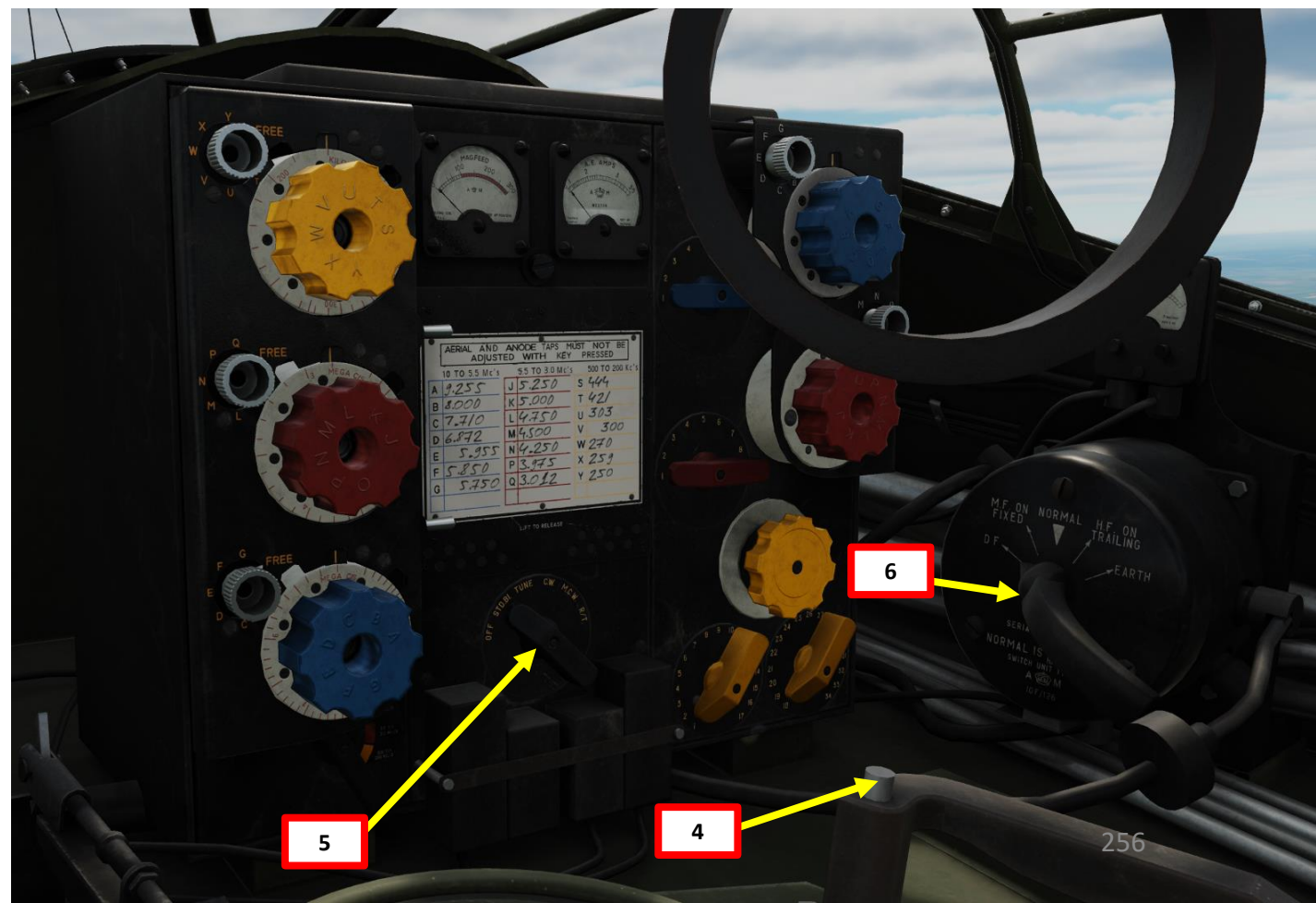

5 – DIRECTION FINDING (D/F) SYSTEM

5.4 – Visual D/F Tutorial

7. Set R1155 Radio Receiver Set Master Selector Switch – Balance. We will need to use this mode to set up the Direction Finding Visual Indicator's reference amplitude and balance settings.
8. Confirm that the Tuning Indicator Light illuminates
9. Set the R1155 Radio Receiver Set Frequency Range Switch to the appropriate frequency range ("18/7.5" for frequency 8 MHz).
10. Use tuning knobs to set radio frequency needle to the appropriate frequency (8 MHz). Since we use the 18/7.5 frequency range, we use the outermost band.
 - Use the outer tuning knob for coarse tuning (big needle movements) and the inner tuning knob for fine tuning (small needle movements).
11. Adjust Volume Control.

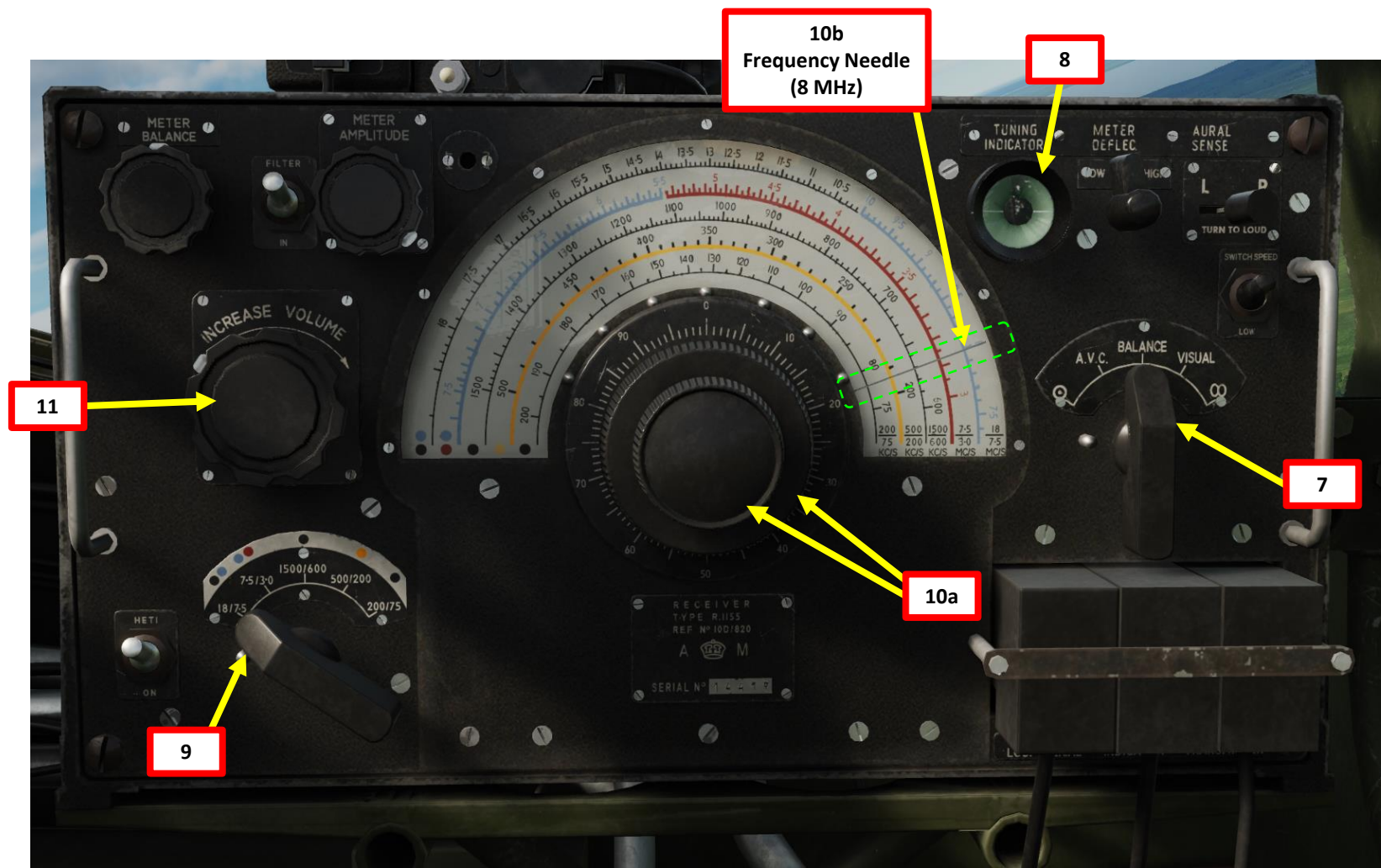

5 – DIRECTION FINDING (D/F) SYSTEM

5.4 – Visual D/F Tutorial

12. While the R1155 Radio Receiver Set Master Selector Switch is set to balance, we need to set the Visual Indicator's balance reference by turning the "Meter Balance" knob to line up the indicator lines on the central vertical line.
13. While the R1155 Radio Receiver Set Master Selector Switch is set to balance, we need to set the Visual Indicator's amplitude reference by turning the "Meter Amplitude" knob to set the crossing point of the indicator lines at about the halfway point of the vertical line.
14. Set Meter Deflection Sensitivity Switch to HIGH if high sensitivity of the visual indicator needles is required (useful when radio emitter is far away) or to LOW if low sensitivity is required.

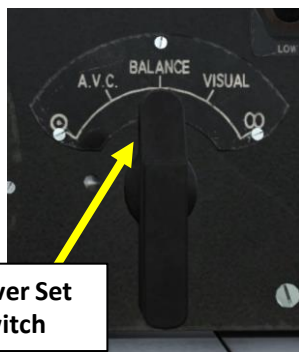

R1155 Radio Receiver Set Master Selector Switch

Meter Amplitude Control
Adjusts the needles of the visual indicator to a convenient point on the meter scale



13

Meter Deflection Sensitivity Switch
Provides comparatively LOW sensitivity of the visual indicator for homing purposes, or HIGH sensitivity of the visual indicator when taking bearings by the visual method.

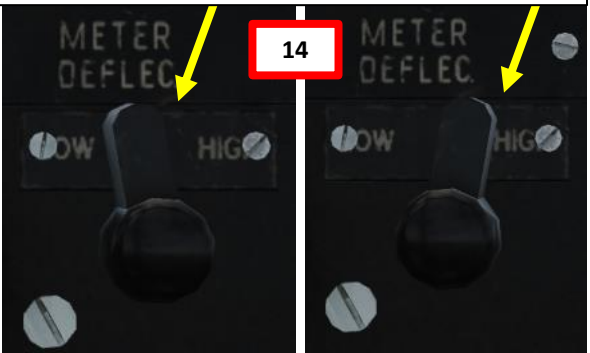

14



Meter Balance Control
Is in circuit when the Master Switch is in either the BALANCE or VISUAL position.

12

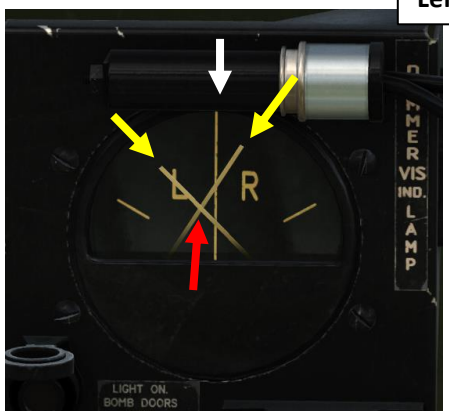

12a
Meter Not Balanced

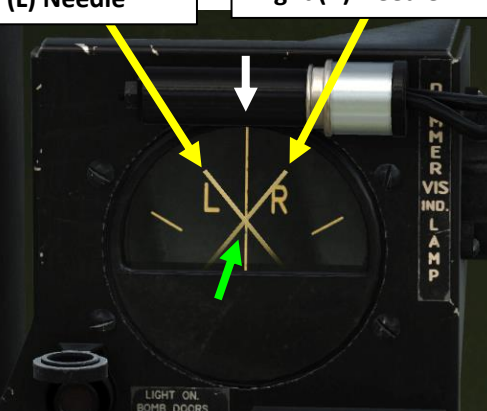

12c
Meter Balanced

Direction Finding Left (L) Needle

Direction Finding Right (R) Needle

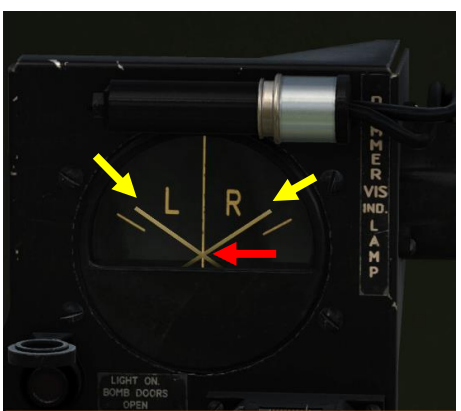

13a
Meter Amplitude Too Low

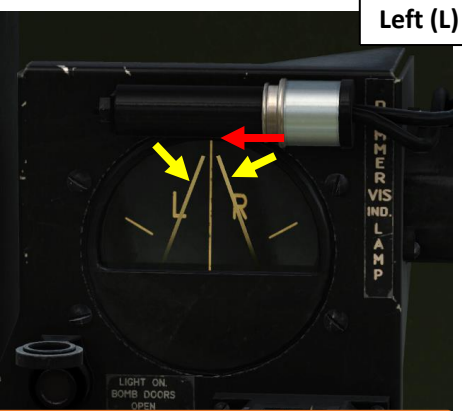

13b
Meter Amplitude Too High

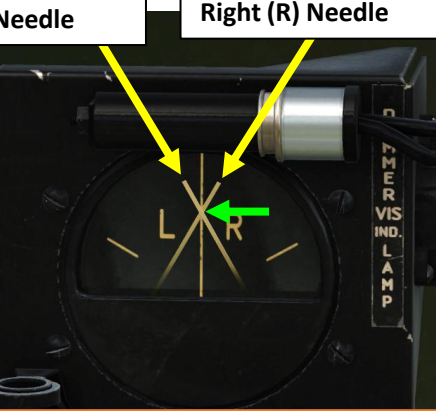

13b
Meter Amplitude Correct

Direction Finding Left (L) Needle

Direction Finding Right (R) Needle

5 – DIRECTION FINDING (D/F) SYSTEM

5.4 – Visual D/F Tutorial

15. Set R1155 Radio Receiver Set Master Selector Switch – VISUAL.
16. Make sure the Loop Antenna unlocked and oriented to “000” on the upper black scale. This means that the visual indicator needles will use the relative aircraft heading as a reference (“000” pointing ahead of the aircraft) to indicate deviation from the reference axis. Lock the antenna back after it is set to the “000” position.



15

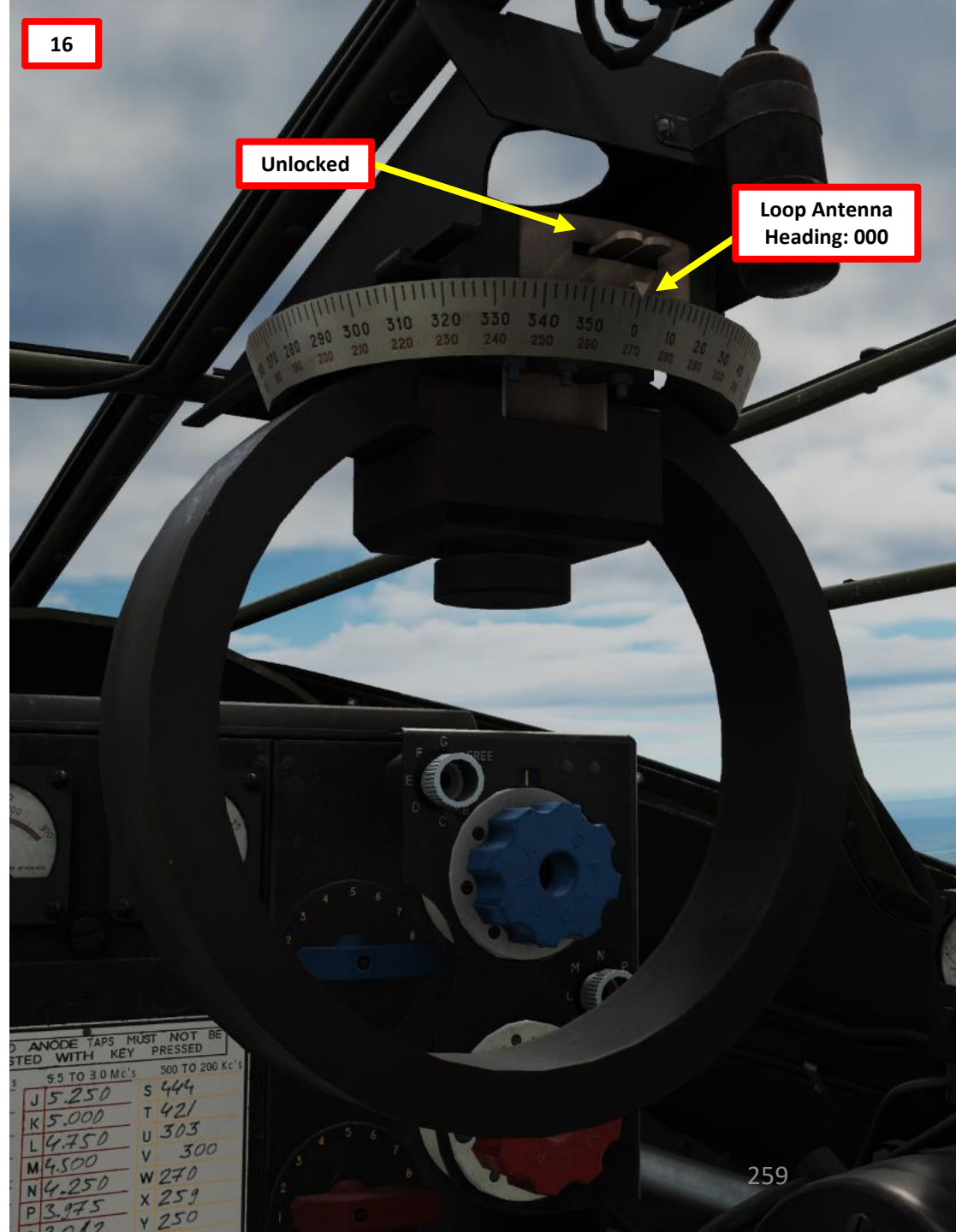

16

5 – DIRECTION FINDING (D/F) SYSTEM

5.4 – Visual D/F Tutorial

17. In this example, we are currently flying at a heading of 005. The needles on the Visual Indicator show that the radio emitter is to our right.
18. Keep steering right until both needles on the Visual Indicator cross the vertical reference line. When both needles cross the vertical line, it means the aircraft is heading straight towards the radio emitter.

Here is a good example by Reflected Simulations: <https://youtu.be/tGXSLKSiRk?t=400>

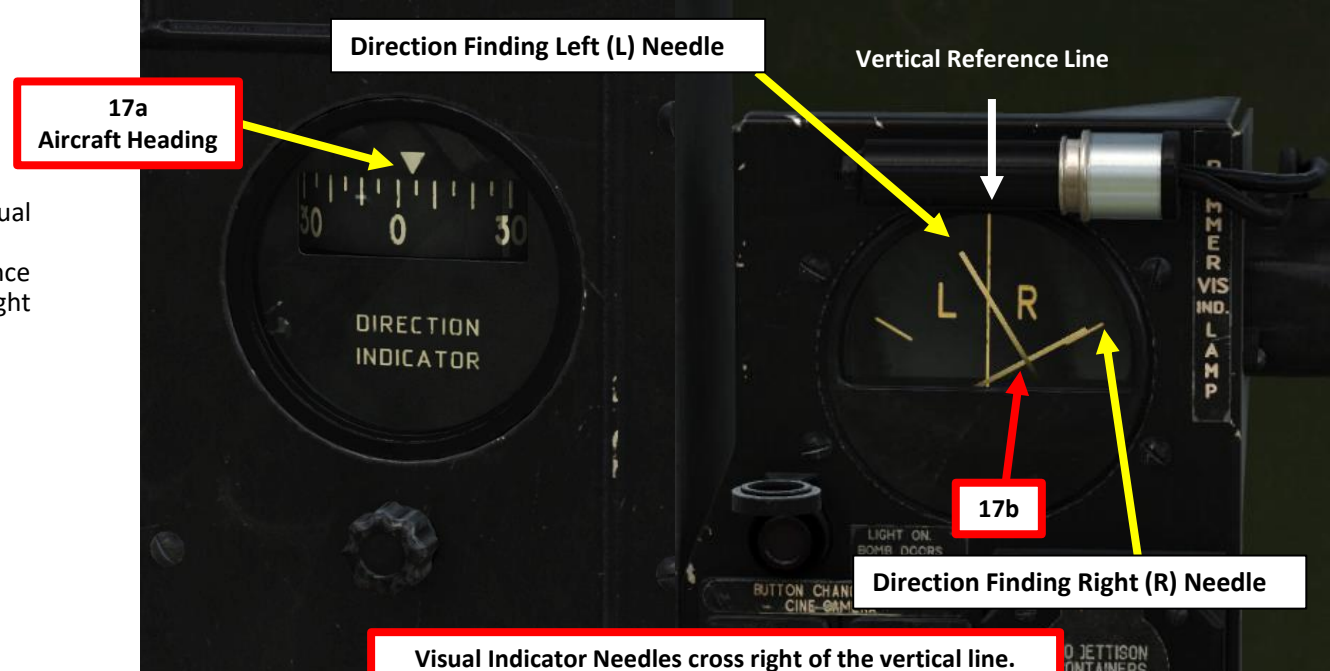
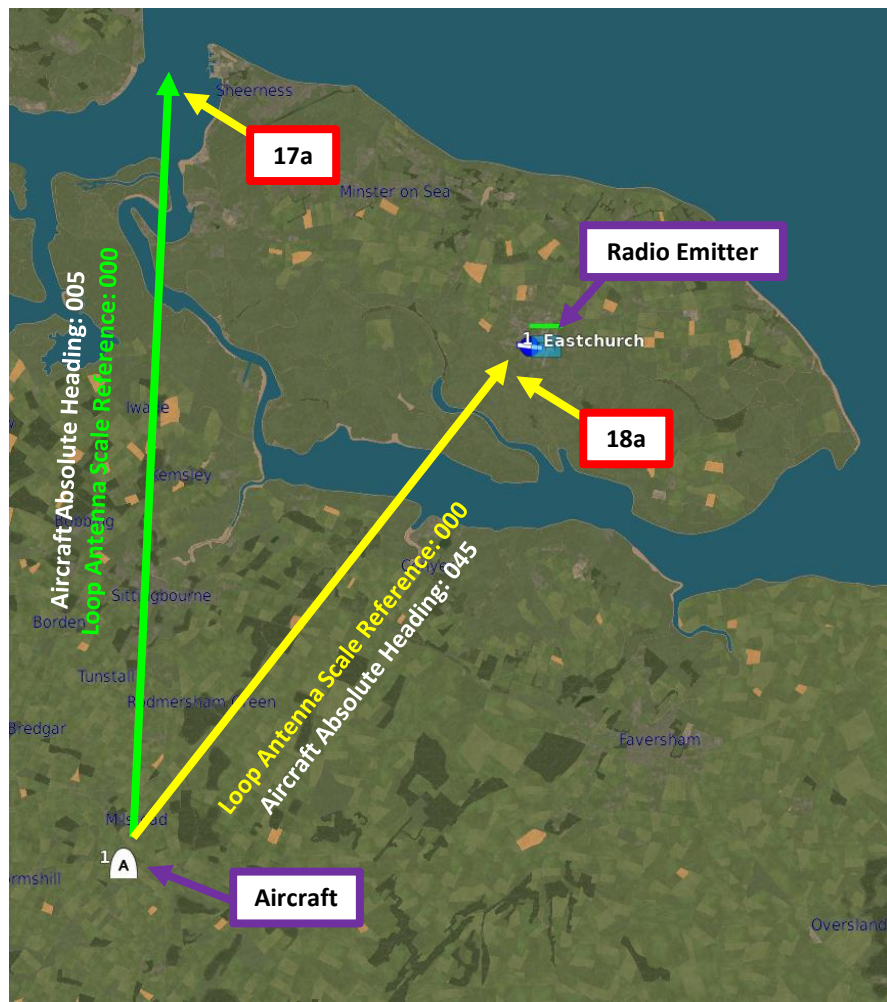

Visual Indicator Needles cross right of the vertical line.
Radio Emitter is to our RIGHT



Visual Indicator Needles cross the vertical line.
Radio Emitter is straight ahead

6 – A1271 BEAM APPROACH SYSTEM

The During the 1930s and 1940s, a Standard Beam Approach (SBA) receiver was used by aircraft, to land when visual conditions were poor (due to rain, low cloud, or fog). It was a navigation receiver, and allowed the pilot to line the aircraft up on the runway when preparing in to land. You can think of it like a primitive form of ILS (Instrument Landing System), but only with a lateral component.

The most important pre-war Navigation Aid (navaid) was the Lorenz Radio Range, developed in Germany as a Blind Landing System (BLS), and was used extensively in Europe. It was developed starting in 1932 by Dr. Ernst Kramar of the Lorenz company. It was adopted by Lufthansa in 1934 and installed around the world. Lorenz used a 33.33 MHz radio transmitter, which projected two overlapping beams down the runway. The beams were switched on and off alternately, the left beam creating “*dits*” (morse letter E), the right beam creating “*dahs*” (morse letter T). Where the beams overlapped along the runway centerline, a continuous tone was heard.

On approach, when the pilot heard *dits*, he turned right until he heard the steady tone. Similarly if he heard *dahs*, he turned left. This was an aural navigation method, meaning that you used the morse signal sounds to determine whether you were to the left, to the right or directly lined up with the runway center. The pilot had to listen to the tones in his earphones and fly accordingly.

The Lorenz system was installed at many British airfields and called Standard Beam Approach (SBA). It used the morse letter A (*dit dah*) for the left beam, and the morse letter N (*dah dit*) for the right beam. In the middle, these overlapped to form the steady tone.

Reference: http://www.tuberadio.com/robinson/museum/command_SBA/



6 – A1271 BEAM APPROACH SYSTEM

Here is an example of the concept behind the Standard Beam Approach (SBA).

The Standard Beam Approach system currently simulated in DCS is based on the Lorenz signals: a series of “dits” (Morse code for “E”) for the station right of the runway and a series of “dahs” (Morse code for “T”) for the station left of the runway.

The signal codes might change eventually, but the method remains the same: use audio signals to determine where you are in relationship to the runway, and steer the aircraft until both signals overlap and create a steady aural tone.

Here is a useful tutorial by Reflected Simulations:
<https://youtu.be/tGXSLKSiRk?t=737>

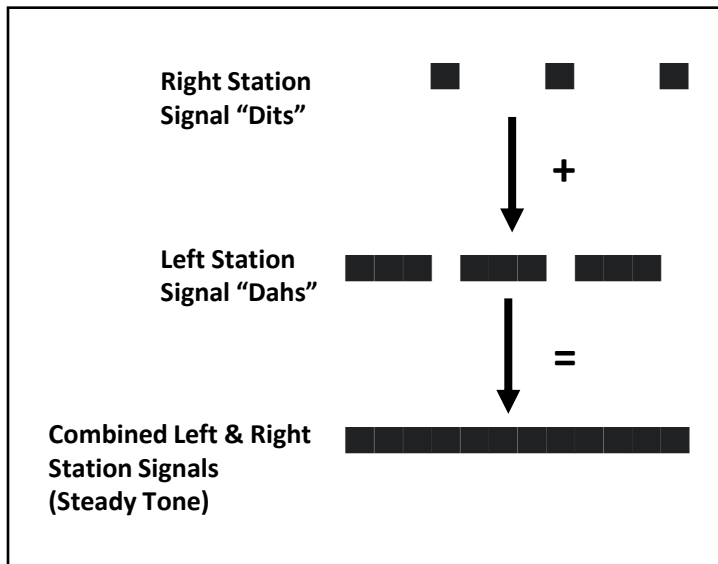

International Morse Code

1. The length of a dot is one unit.
2. A dash is three units.
3. The space between parts of the same letter is one unit.
4. The space between letters is three units.
5. The space between words is seven units.

A	• —	U	• • —
B	— • • •	V	• • • —
C	— • — •	W	• — • —
D	— • • •	X	— • • —
E	•	Y	— • — •
F	• • — •	Z	— — • •
G	— — • •		
H	• • • •		
I	• •		
J	• — — —		
K	— • — —	1	• — — — —
L	• — • •	2	• • — — —
M	— —	3	• • • — —
N	— •	4	• • • • —
O	— — —	5	• • • • •
P	• — — •	6	— • • • •
Q	• — — • •	7	— — • • •
R	• — • •	8	— — — • •
S	• • • •	9	— — — — •
T	—	0	— — — — —

Aircraft flying in Right Beam Only

- Signal “Dits” audible
- Signal “Dahs” not audible

Aircraft flying in Left Beam Only

- Signal “Dits” not audible
- Signal “Dahs” audible

Aircraft flying in Both Left & Right Beams (aligned with runway centerline)

- Signal “Dits” and “Dahs” are both audible
- Both signals overlap, creating a steady signal tone.

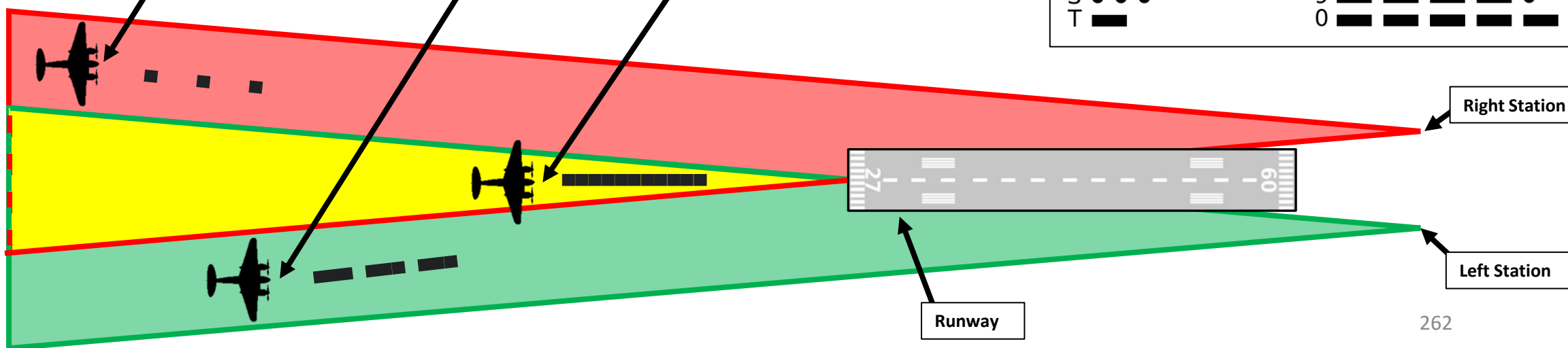

6 – A1271 BEAM APPROACH SYSTEM

In the aircraft, there is no way to manually tune the frequency use for the Beam Approach system. The frequency is preset via the Mission Editor for the airfield you plan to return to. Since each frequency is different from airfield to airfield, you can only use the beam approach for one single runway.

DCS currently simulates the Beam Approach frequency by using the ILS (Instrument Landing System) frequency of airfields equipped with ILS equipment. Take note that the Normandy and Channel maps do not have the Beam Approach beacons yet.

AIRDROME DATA		FG94
NAME	Kobuleti	
ICAO	UG5X	
COALITION	Neutral	
ELEVATION	59 ft	
RWY Length	7406 ft	
COORDINATES	41°55'55"N 41°52'35"E	
TACAN	67X (KBL)	
VOR	--	
RSBN	--	
ATC	4.350, 133.000, 40.800, 262.000	
RWYs	25	7
ILS	--	111.50 (IKB)

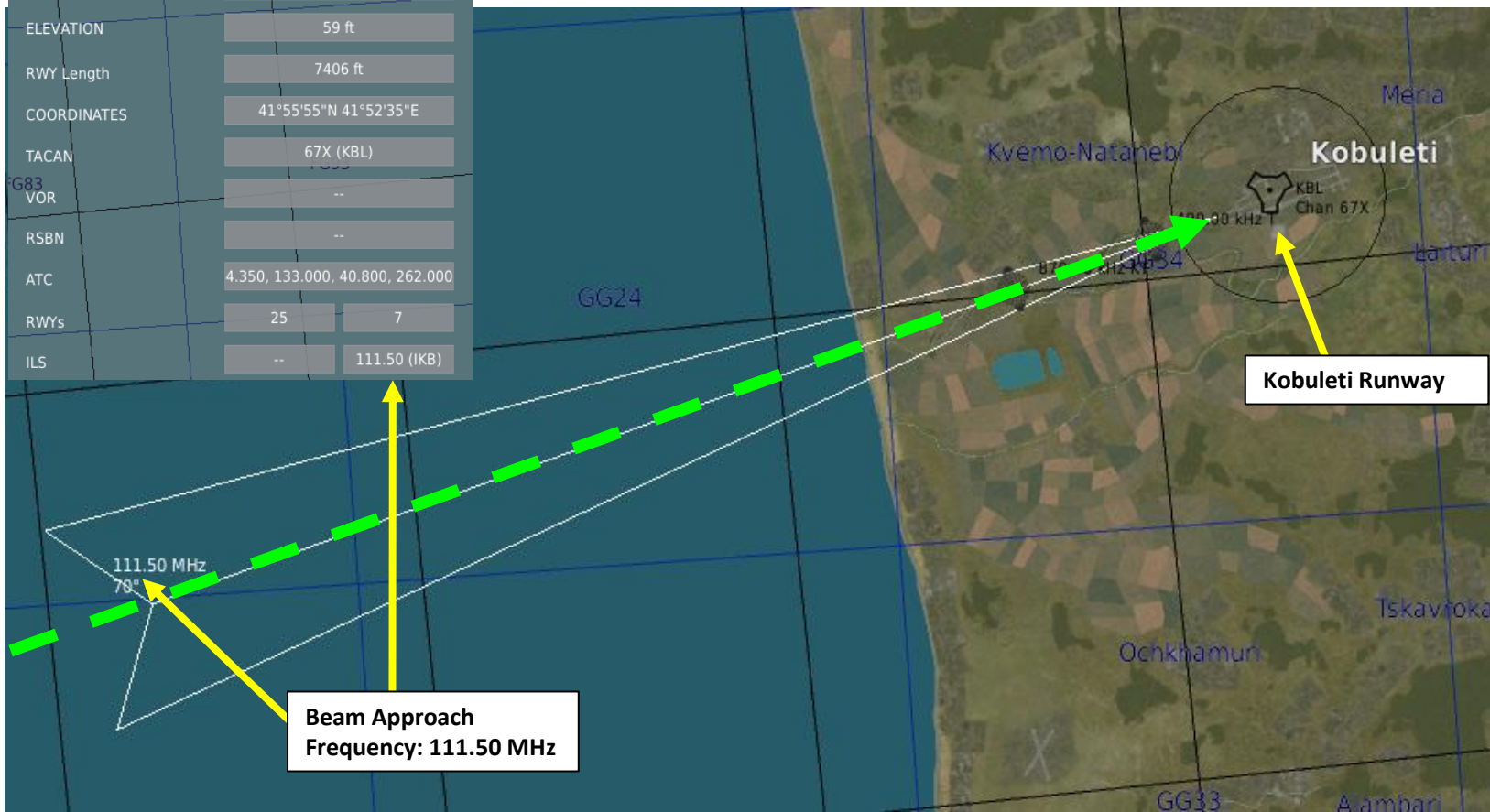

Beam Approach Frequency: 111.50 MHz

Kobuleti Runway

AIRPLANE GROUP

NAME: Aerial-1

CONDITION: % < > 100

COUNTRY: UK **COMBAT**

TASK: CAP

UNIT: < > 1 OF < > 1

TYPE: Mosquito FB Mk. VI

SKILL: Player

PILOT: Aerial-1-1

TAIL #: THCKA512

RADIO: FREQUENCY: 124 MHz AM

CALLSIGN: Enfield 1 1

HIDDEN ON MAP

HIDDEN ON PLANNER

HIDDEN ON MFD LATE ACTIVATION

TR.1143

Channel A	< > 124	MHz	AM
Channel B	< > 124	MHz	AM
Channel C	< > 131	MHz	AM
Channel D	< > 139	MHz	AM
A.1271 Base Frequency	< > 111.5	MHz	AM

Beam Approach Frequency: 111.50 MHz

6 – A1271 BEAM APPROACH SYSTEM

In this tutorial, we will use the Beam Approach system for Kobuleti's runway (frequency 111.50 MHz).

1. Make sure the A1271 Base Frequency for the Beam Approach system is set up correctly via the Mission Editor. The A1271 Base Frequency should match the Kobuleti ILS frequency, which is 111.50 MHz.
2. Set Beam Approach A1271 Receiver Power Switch – ON (DOWN)
3. Adjust Beam Approach A1271 Receiver Volume Knob to hear the morse signals from the runway.

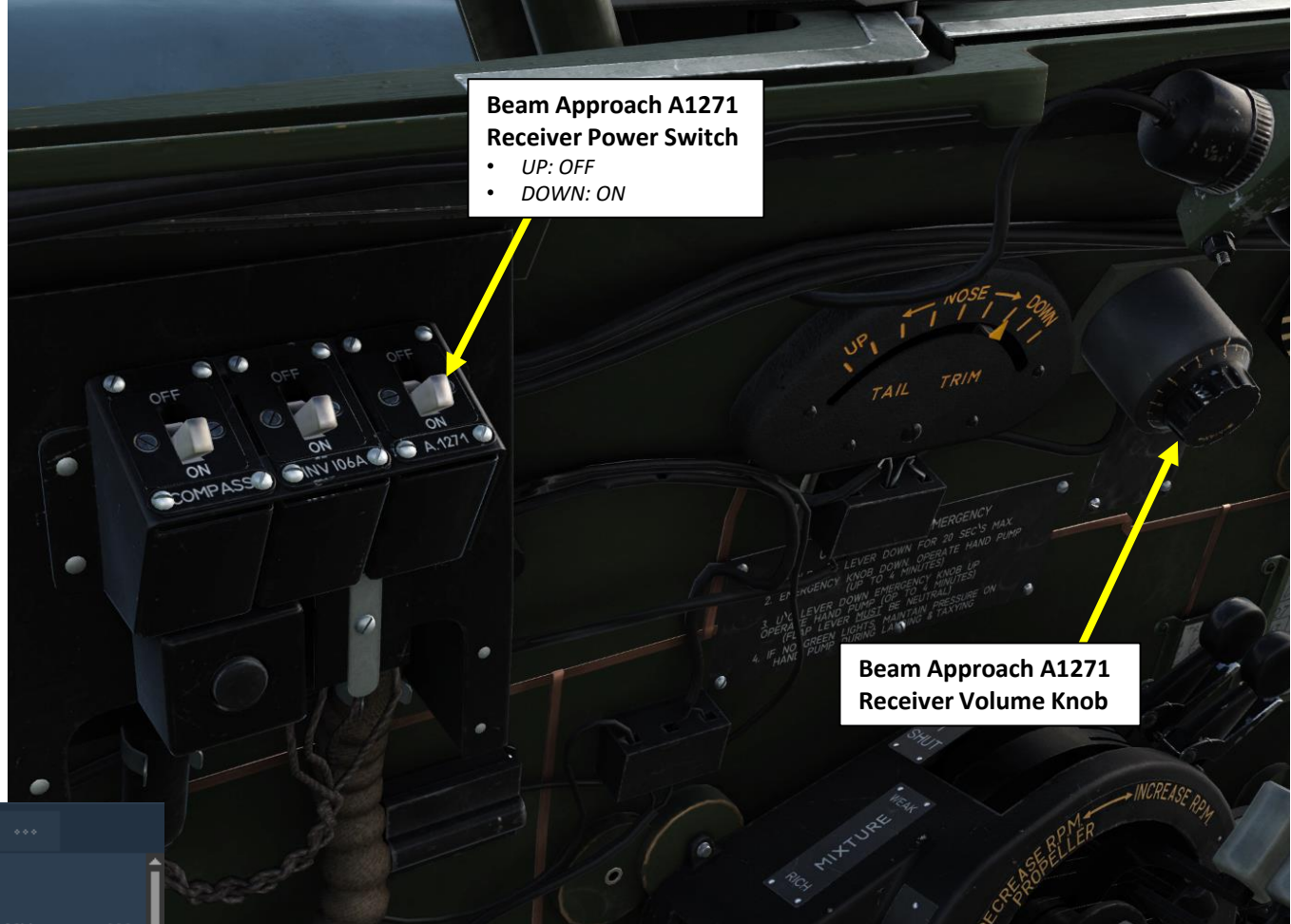

Beam Approach A1271 Receiver Power Switch

- UP: OFF
- DOWN: ON

Beam Approach A1271 Receiver Volume Knob

AIRDROME DATA		FG94
NAME	Kobuleti	
ICAO	UG5X	
COALITION	Neutral	
ELEVATION	59 ft	
RWY Length	7406 ft	
COORDINATES	41°55'55"N 41°52'35"E	
TACAN	67X (KBL)	
G83 VOR	--	
RSBN	--	
ATC	4.350, 133.000, 40.800, 262.000	
RWYs	25	7
ILS	--	111.50 (IKB)

TR.1143			
Channel A	< >	124	MHz AM
Channel B	< >	124	MHz AM
Channel C	< >	131	MHz AM
Channel D	< >	139	MHz AM
A.1271 Base Frequency	< >	111.5	MHz AM

Beam Approach Frequency: 111.50 MHz

6 – A1271 BEAM APPROACH SYSTEM

4. Determine your current position base on what kind of audio signal you hear:
 - A series of short “dits” (Morse code for “E”) is for the station right of the runway. This means the runway is further to your right.
 - A series of long “dahs” (Morse code for “T”) for the station left of the runway. This means the runway is further to your left.
 - A steady tone means both the left and right station signals overlap, which means that you are lined up with the runway.
5. The Beam Approach gives you your position relative to the runway, but it does not indicate whether you are flying in the correct direction or not. To ensure the aircraft heading is correct, make sure to use the Directional Gyro and Remote Indicating (R.I.) Repeater Compass to follow the Magnetic Heading of Kobuleti’s runway (064).
6. Fly the aircraft while the tone is steady and perform the landing approach as per the procedure in the landing tutorial.

Kobuleti Runway 07

- Magnetic Heading: 064 (indicated on map)
- True Heading: 070

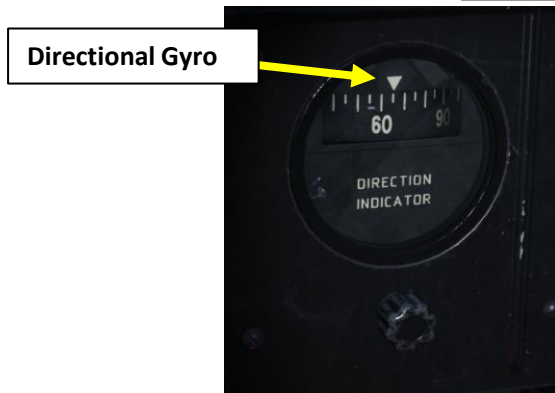
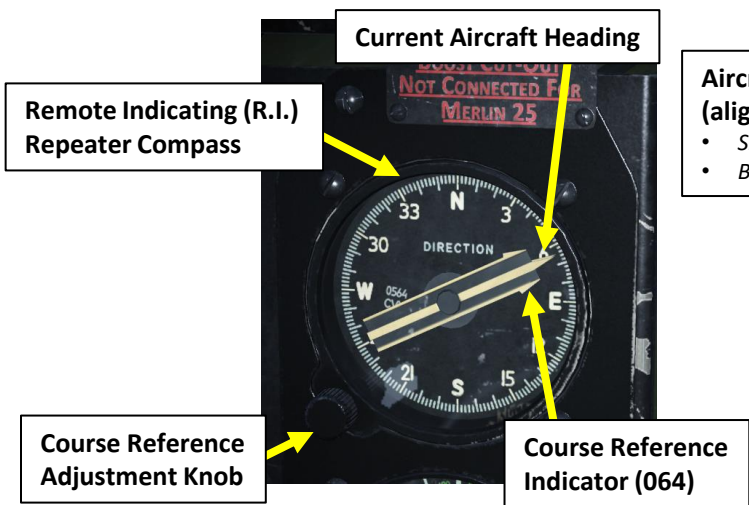
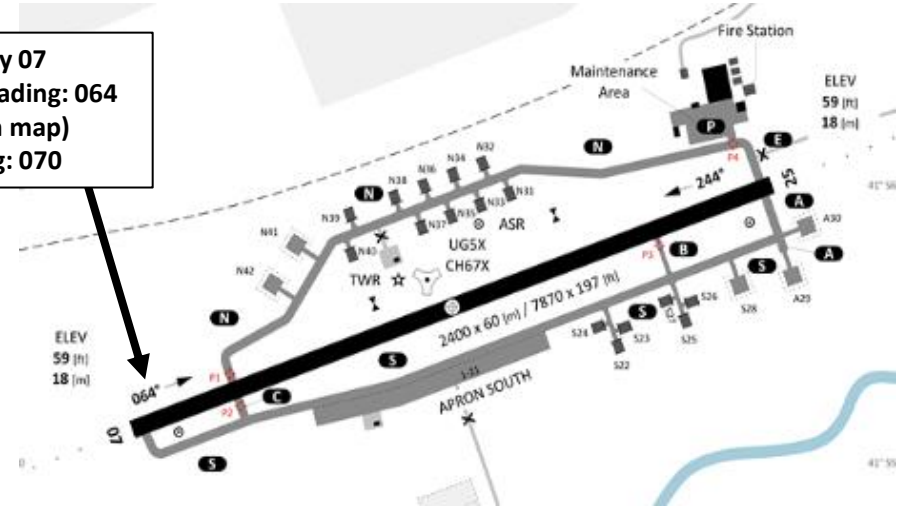

Aircraft flying in Both Left & Right Beams (aligned with runway centerline)

- Signal “Dits” and “Dahs” are both audible
- Both signals overlap, creating a steady signal tone.

Aircraft flying in Right Beam Only

- Signal “Dits” audible
- Signal “Dahs” not audible

Aircraft flying in Left Beam Only

- Signal “Dits” not audible
- Signal “Dahs” audible

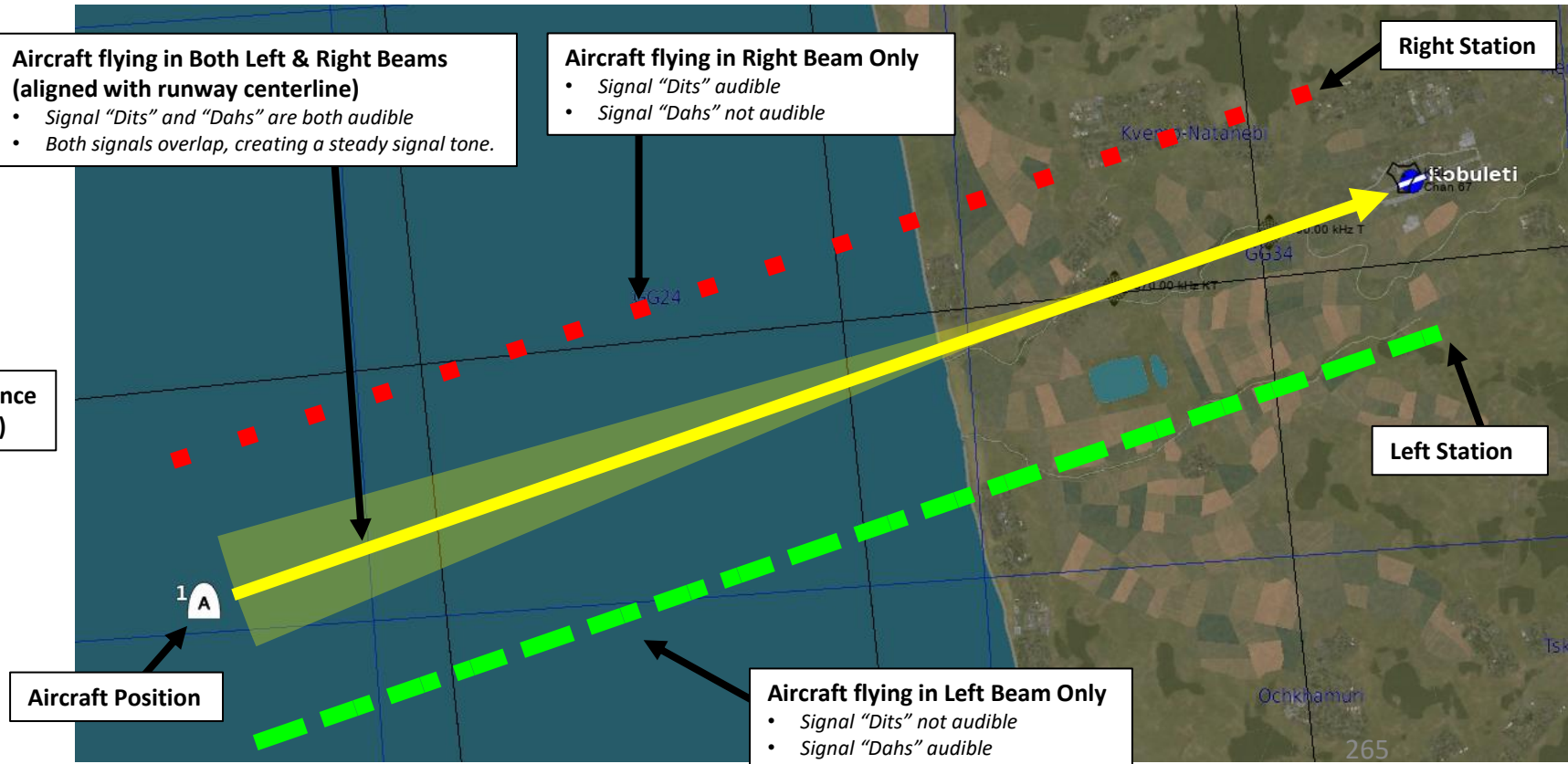



DH.98 MOSQUITO
FB MK VI

PART 12 - NAVIGATION

6 - A1271 BEAM APPROACH SYSTEM



7 – MAGNETIC DEVIATION

The direction in which a compass needle points is known as magnetic north. In general, this is not exactly the direction of the North Magnetic Pole (or of any other consistent location). Instead, the compass aligns itself to the local geomagnetic field, which varies in a complex manner over the Earth's surface, as well as over time. The local angular difference between magnetic north and true north is called the magnetic declination. Most **map coordinate** systems are based on **true north**, and magnetic declination is often shown on map legends so that the direction of true north can be determined from north as indicated by a compass.

This is the reason why in DCS, the course to a runway needs to be “adjusted” to take into account this magnetic declination of the magnetic North pole (which is actually modelled in the sim, which is pretty neat).

True Heading = Magnetic Heading + Magnetic Deviation

As an example, if the runway heading that you read on the F10 map in Kutaisi is 074 (True Heading), then the input to your magnetic compass course should be 074 subtracted with the Magnetic Deviation (+6 degrees), or 068. You would need to enter a course of 068 (M) on the Repeater Compass Course setting.

Magnetic Declination:

- **Caucasus (modern): +6,4° (East)**
- **Nevada (modern): +14.2° (East)**
- **Persian Gulf (modern): +1.3° (East)**
- **Normandy (1944): +8° (East)**
- **English Channel (1940): +7° (East)**
- **Syria (modern): +5.2 ° (East)**

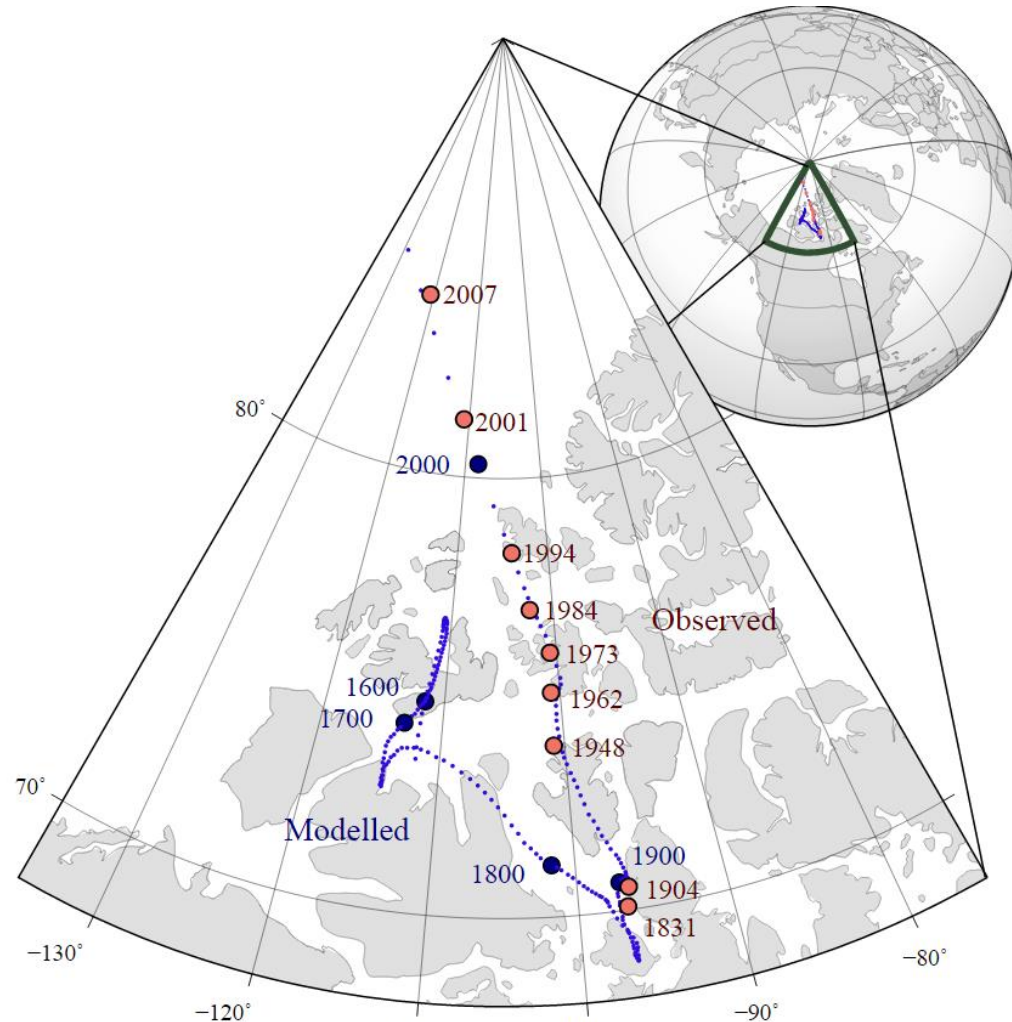
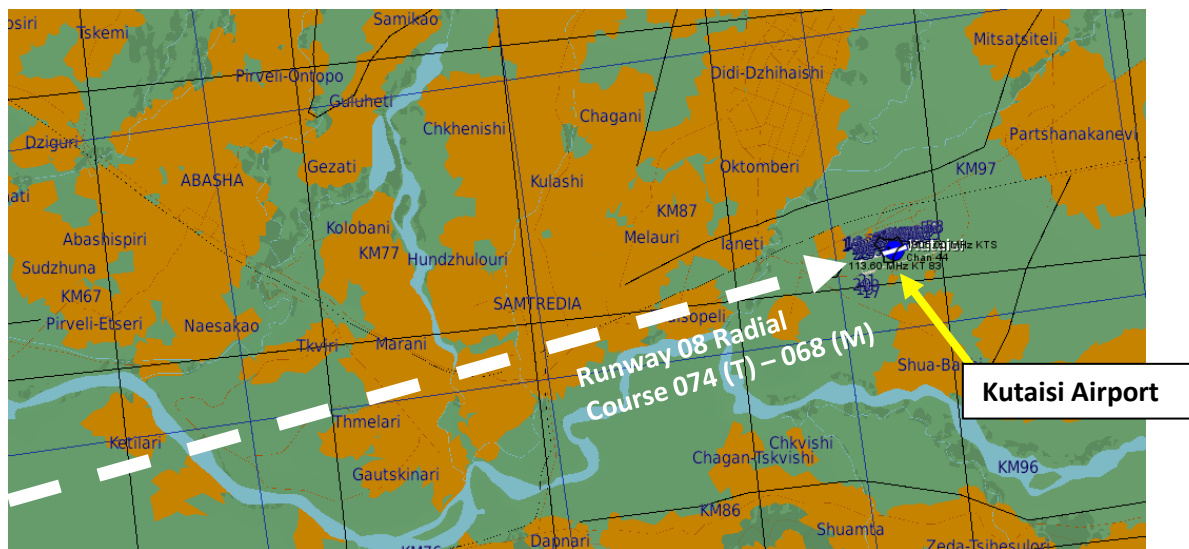

The movement of Earth's north magnetic pole across the Canadian arctic, 1831–2007.

Magnetic Deviation Tables for Normandy and Channel Maps

Normandy (1944): <https://dcs.beyondreality.se/pdfs/NormandyAirfields.pdf>

Channel Map: <https://dcs.beyondreality.se/pdfs/ChannelAirfields.pdf>

8 – DRIFT RECORDER DEVICE

- The Periscopic Drift Sight allows the navigator to determine drift angle due to the winds. The periscopic sight is not simulated in DCS yet.



Drift Scale

A drift meter consists of a small telescope extended vertically through the bottom of the aircraft with the eyepiece inside the fuselage at the navigator's station. A reticle, normally consisting of spaced parallel lines, is rotated until objects on the ground are seen to be moving parallel to the vertical lines. The angle of the reticle then indicates the aircraft's drift angle due to winds aloft. It is also used to calculate the ground speed by measuring the time it takes for an object on the ground to pass from the upper to the lower horizontal line of the reticle.

Drift sights were used to estimate the sideways drift over the ground caused by crosswind. Calculating drift is important for both high level bombing and long distance navigation. This is particularly relevant for over water navigation due to the absence of ground references to obtain fixes.

Feel free to consult this link for museum photos:

<https://www.britmodeller.com/forums/index.php?/topic/235068711-mosquito-fbvi-drift-sight-questions/&do=findComment&comment=3597530>

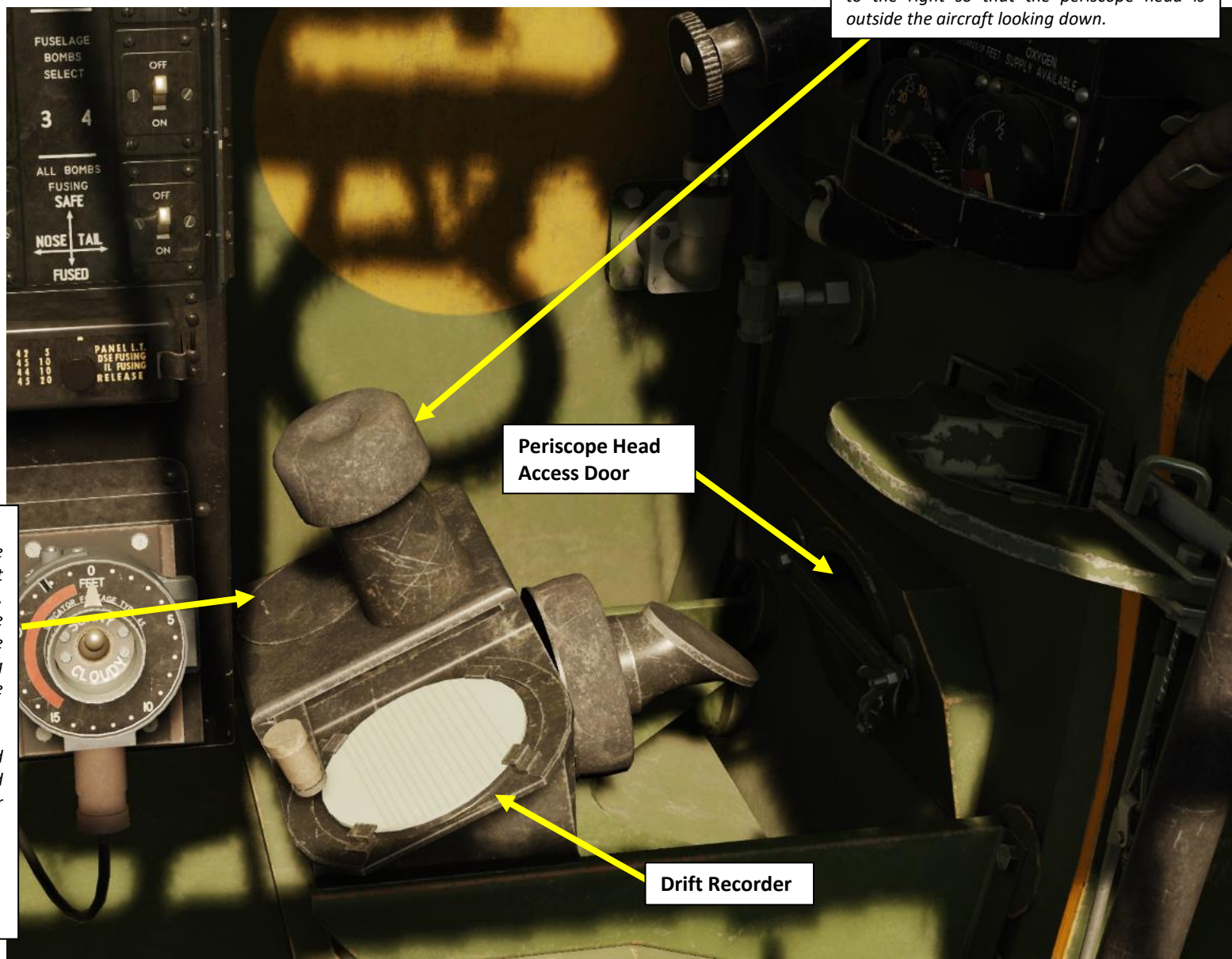

Periscopic Drift Sight

Stowed Position. When in use, the sight is slid to the right so that the periscope head is outside the aircraft looking down.

Periscope Head
Access Door

Drift Recorder

9 – OBOE SYSTEM

9.1 – What is “Oboe”?

“Oboe” was a British aerial blind bombing system of the second world war based on radio transponder. This system was used to guide bombers to a specific target and provide cue signals to let the pilot and navigator know if they were following the pre-planned route or not.

The Oboe system consisted of a pair of radio transmitters on the ground, which sent signals which were received and retransmitted by a transponder in the aircraft. **By comparing the time each signal took to reach the aircraft, the distance between the aircraft and the station could be determined.** The Oboe operators then sent radio signals to the aircraft to bring them onto their target and properly time the release of their bombs.

The system was first used in December 1941 in short-range attacks over France where the necessary line of sight could be maintained. To attack the valuable industrial targets in the Ruhr, only the de Havilland Mosquito flew high enough to be visible to the ground stations at that distance. Such operations began in 1942, when Pathfinder squadron Mosquitos used Oboe both to mark targets for heavy bombers, as well as for direct attacks on high-value targets. In an attack on 21 December 1942, Oboe-guided bombers dropped over 50% of their bombs on the Krupp factories in Essen, an enormous improvement over previous efforts that resulted in less than 10% of bombs landing on their targets. Versions using shorter wavelengths demonstrated accuracy on the order of 15 meters (about 50 ft).

Oboe was used extensively by Pathfinder marker aircraft during the Battle of the Ruhr in 1943. In December 1943 Bomber Command began the Battle of Berlin, which was beyond the range of Oboe. For this campaign, Bomber Command was forced to rely on the H2S ground mapping radar instead, which never was able to provide the consistent accuracy of Oboe.

A later development was the Gee-H system, in which the transponder remained on the ground but the transmitter was mounted in the aircraft where the readout was made. This system allowed around 80 aircraft to be guided at the same time. Neither the H2S ground mapping radar nor Gee-H could provide the accuracy of Oboe, which demonstrated the highest average bombing accuracy of any system in the war.

Take note that the Gee-H and H2S systems were not installed in our DCS Fighter-Bomber Mosquito.

Here is a nice video about Oboe by Jake Howland:
<https://youtu.be/hURdI91MCNQ>

Interesting Oboe article by “Pathfinder Craig”
<https://masterbombercraig.wordpress.com/bomber-command-structure/no-8-pff-group-bomber-command/pathfinder-force-pff/pathfinder-methods/o-boe/>

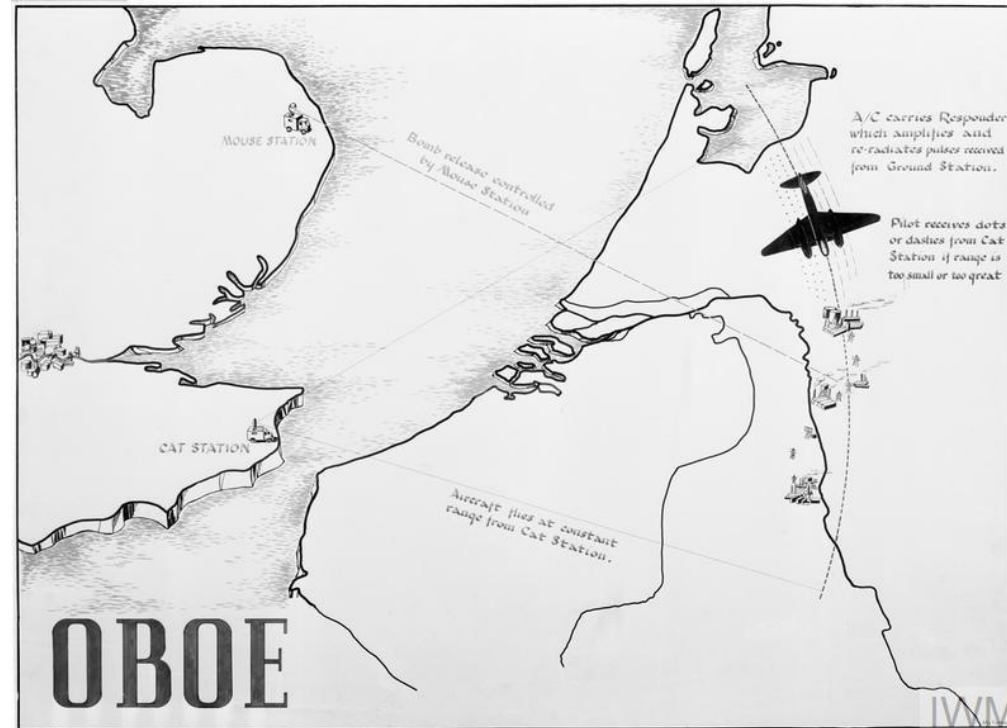

9 – OBOE SYSTEM

9.1 – What is “Oboe”?

The basic concept would be to have two ground stations that would periodically send out signals on similar but separate frequencies. The aircraft carried transponders, one for each signal, which re-broadcast the signals upon reception. By timing the total round trip time from broadcast to reception and then dividing by twice the speed of light (the signal travels to the aircraft and back again) the distance to the aircraft could be determined. This was essentially identical to radar, with the exception that the transponder (transmitting at a frequency of about 200 MHz) greatly amplified the signals for the return journey, which aided accuracy by providing strong, sharply defined signal pulses.

Before the mission, a path was defined that represented the arc of a circle whose radius passed through the target as measured from one of the two stations. This station was given the name "Cat". The aircraft would then use conventional navigation techniques, dead reckoning or Gee if it was equipped, to place itself some distance north or south of the target on a point near this line. They would then begin flying towards the target, at which point an operator at Cat would call out corrections to have the aircraft fly closer or further from the station until it was flying at precisely the right range to keep it on the circle

- The first station, code-named “**Cat**”, continued to keep the aircraft positioned at this precise distance as it flew towards the target, causing the aircraft to fly along the pre-defined arc.
- The second station, code-named "**Mouse**", calculated the range to the target before the mission. As the Mosquito approached that predetermined range, they would first call out a "heads up" to tell the bomb aimer to begin the run, and then a second signal at the right time to drop it.

Using this method there was no need for the two stations to compare measurements or perform any trigonometry to determine an actual location in space, both performed simple range measurements directly off their screen and sent their separate corrections to the aircraft.

In practice, ranges were not sent by voice to the aircraft. Instead, a tone generator produced Morse code dots or dashes under the control of the operators. This was similar to the beam systems like Lorenz, which the UK aircrew were already familiar with using as a blind landing aid in the pre-war period. If the aircraft was too close to the station the operator would play the dot signal, and when they were too far, dashes. The two could be mixed so that as they approached the correct range, the dots would fill in the gaps between the dashes and form a steady tone.[4]

Periodically the signal would be keyed to send out a letter to indicate how far they were from the correct range, X indicating 20 miles (32 km), Y 10 miles (16 km), and Z 5 miles (8.0 km). Likewise, the Mouse station sent a series of keyed signals to indicate the approach, S to indicate the approach was starting, and then A, B, C and D as the aircraft approached.

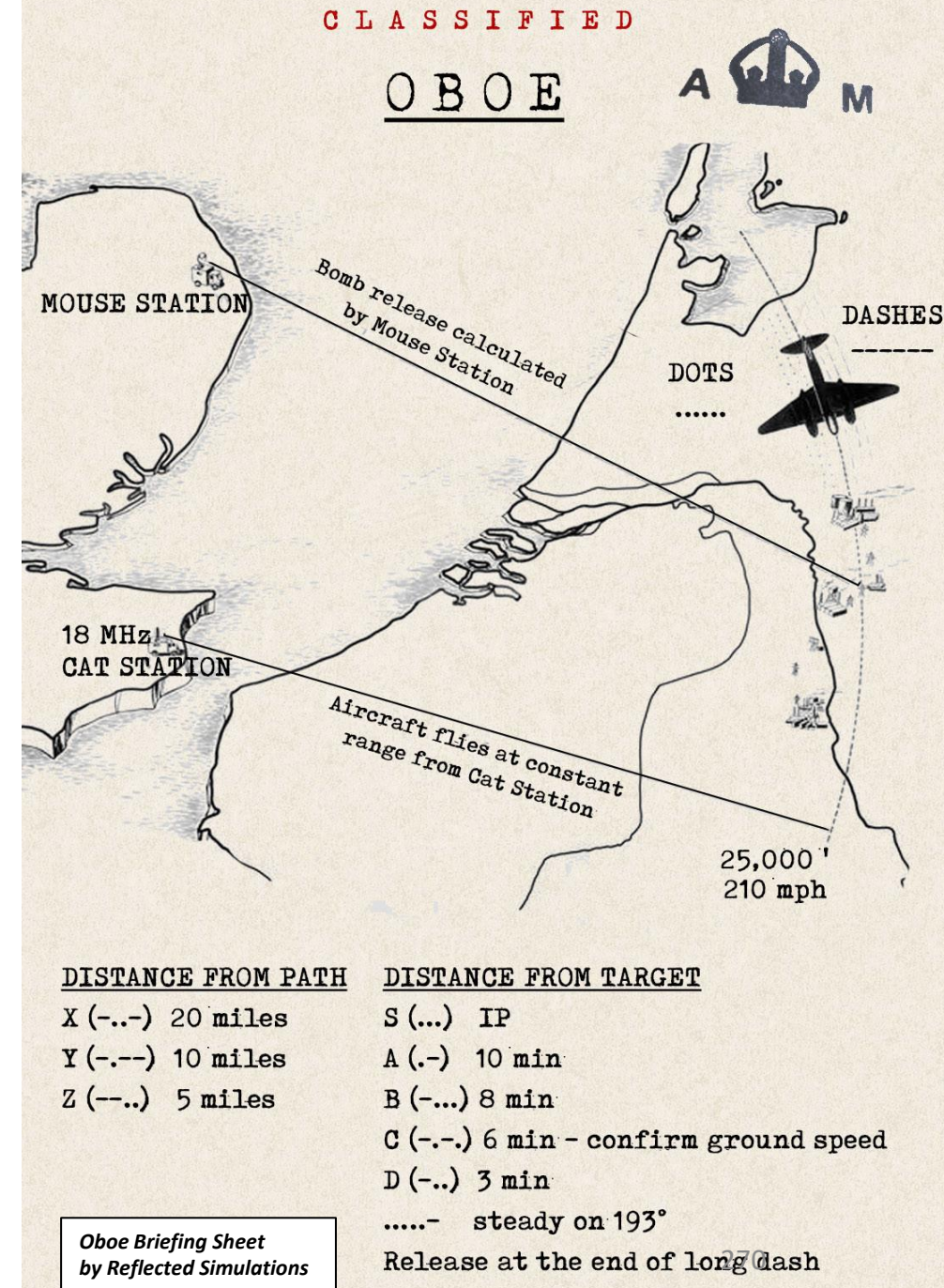

9 – OBOE SYSTEM

9.1 – What is “Oboe”?

Here is an overview of the Oboe system with the Cat and Mouse Stations, including reference points.

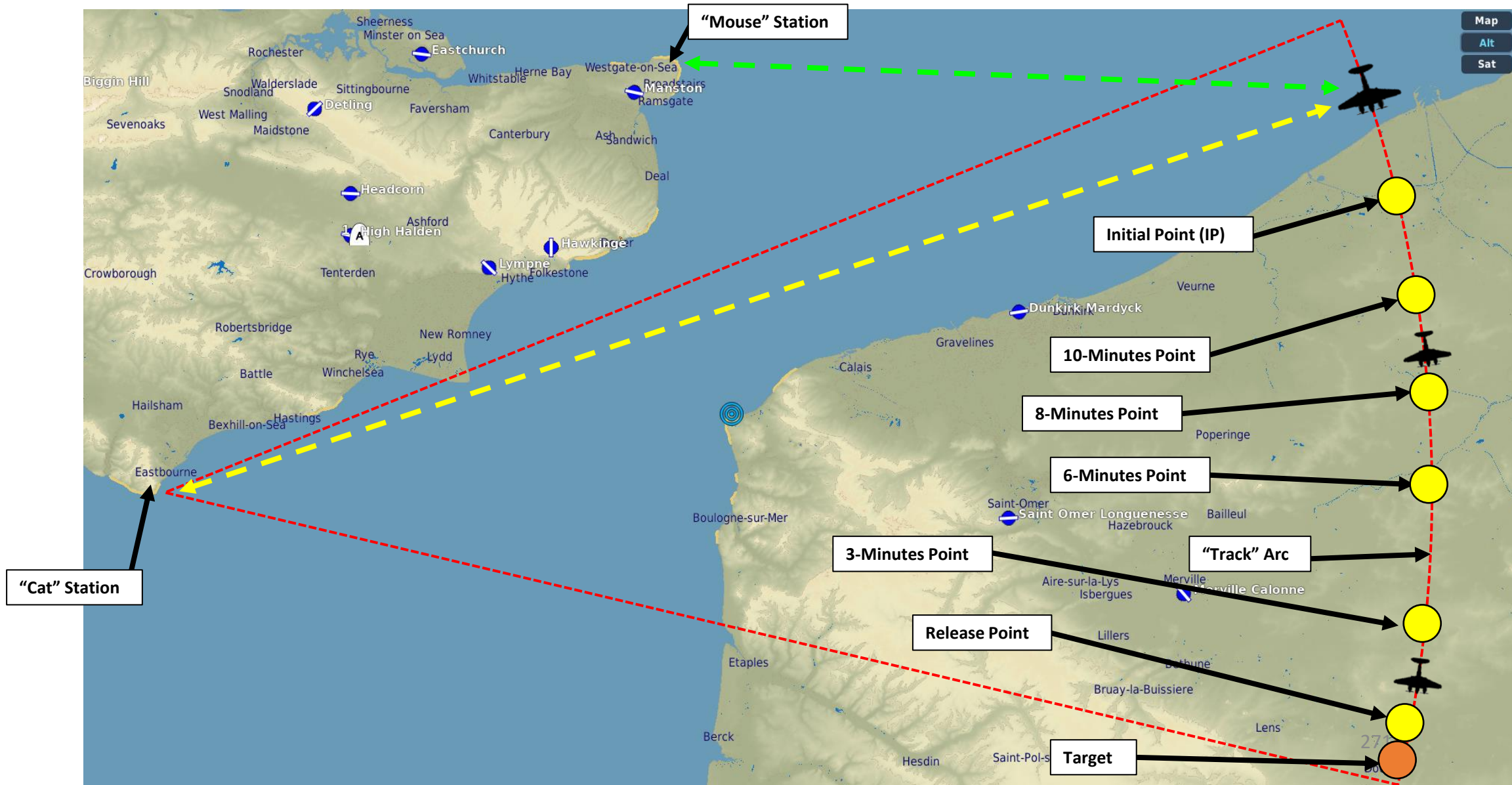

9 – OBOE SYSTEM

9.1 – What is “Oboe”?

Oboe was first used by Short Stirling heavy bombers in December 1941, attacking Brest. In December 1942, Oboe on Mosquitos was trialed at Lutterade. Half of the Oboe units malfunctioned in some way. This was about the same time as H2S ground mapping radar was introduced. The Germans, observing the curved path of the Mosquito, called the system "Boomerang". The predictable path of the bomber was a vulnerability, compensated for by the fact that the speed and altitude of the Mosquito made it very hard to intercept. The major limitation of Oboe was that it was a line-of-sight system; the curvature of the Earth therefore allowed it to be useful for attacking the Ruhr industrial area, but not targets deeper inside Germany.

Oboe was extremely accurate. In his book "Most Secret War", British physicist R. V. Jones wrote, "As it turned out, Oboe was the most precise bombing system of the whole war. It was so accurate that we had to look into the question of the geodetic alignment of the Ordnance Survey with the Continent, which effectively hinged on triangulation across the straits of Dover." With an error radius of about 110 metres (120 yards) at a range of 400 kilometers (215 nm), Oboe was about as good as optical bombsights. Late in the war, it was used for humanitarian purposes to assist food drops to the Dutch still trapped under German occupation, as part of Operation Manna. Drop points were arranged with Dutch Resistance contacts and the food canisters were dropped within about 30 m (98 ft) of the aiming point thanks to Oboe.

It took the Germans more than a year to discover the mystery of the system. Oboe was cracked by engineer H. Widdra (who had already detected the British "Pip Squeak" (IFF, Identify-Friend-or-Foe) in 1940) at the end of August 1943 at the RF tracking station "Maibaum", located in Kettwig near Essen, while the British bombers attacked the steelworks of "Bochumer Verein".

The Germans tried to jam 1.5 metre / 200 MHz Oboe signals, though by the time they did the British had moved on to the 10 cm / 3 GHz Mk.II Oboe and were using the old transmissions as a ruse. This was discovered in July 1944 after its operator failed to properly mark a drop using the Mk.1 signals.

The Mk.III of April 1944, was more sophisticated. Four aircraft could operate on one frequency and the system could accommodate approaches other than simple radial ones.



9 – OBOE SYSTEM

9.2 – Principles Behind “Oboe”

The main principle behind Oboe are based on the physics of radio signals. If we draw a Track Line (Arc) to the target with the Cat Station as its center... how can the operator of the station know when the aircraft is crossing the Track Line? Well, if we know the speed at which the radio wave travels.

Problem: We want to know how far the aircraft is from the Cat Station.

Solution: Take the time between Cat station radio transmission and transponder response signal reception, and multiply it by the speed of the radio signal (known). This will give you the travel distance of the wave.

Speed of Radio Signal = 1000 ft / microseconds (uS)

Delay between Cat Station Pulse Signal Emission and Reception of the Transponder Response signal of the Aircraft = 2769.04 uS

Time Requirement (One Way) = Delay / 2 = 2769.04 uS / 2 = 1384.52 uS

Total One-Way Distance between Aircraft and Cat Station (ft) =
 Time Requirement x Speed of Radio Signal = 1384.42 uS x 1000 ft/uS
 = 1384520 ft

Total Distance (miles) = Total Distance (ft) / 5280 ft/mile
 = 262.22 miles

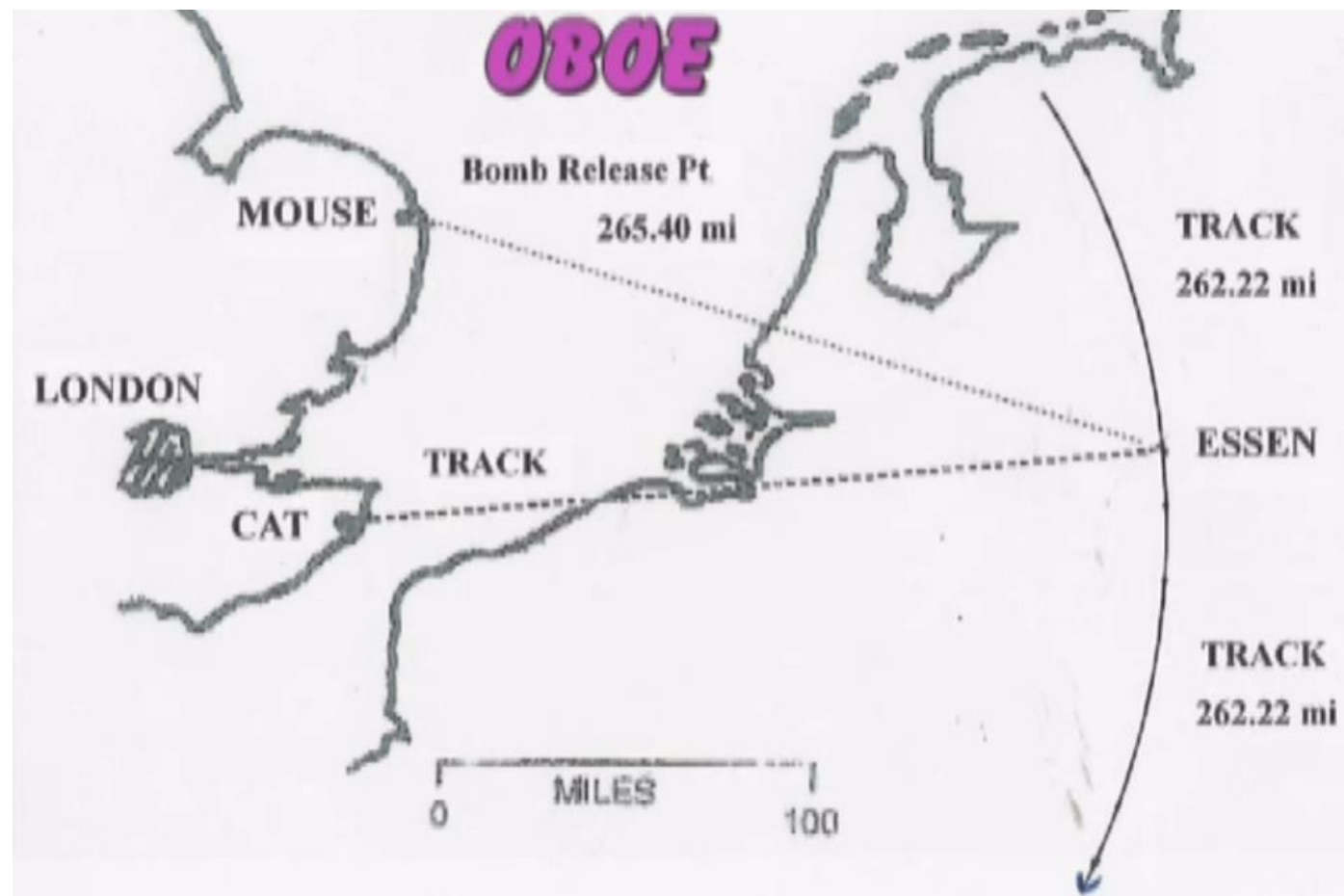

9 – OBOE SYSTEM

9.2 – Principles Behind “Oboe”

The primary role of the Cat Station is to figure out where the aircraft is in relationship to the Track Arc. The radio signals sent to the pilot and navigator indicate whether the aircraft is too near, too far, or directly on the track.

Source: “OBOE - WWII Blind Bombing System (precursor to GEE)” by Jake Howland:
<https://youtu.be/hURdI91MCNQ>

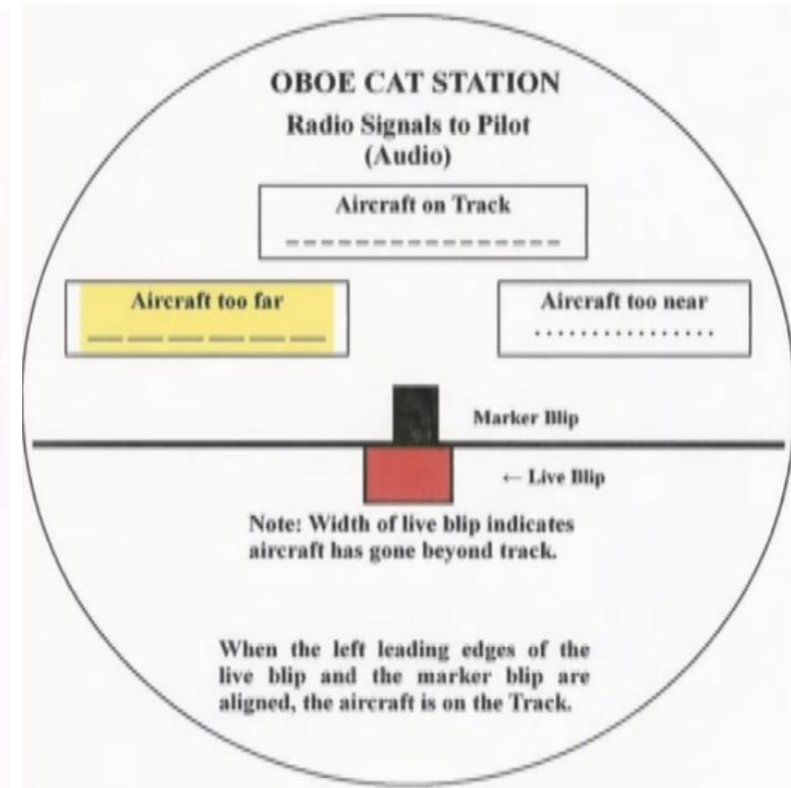
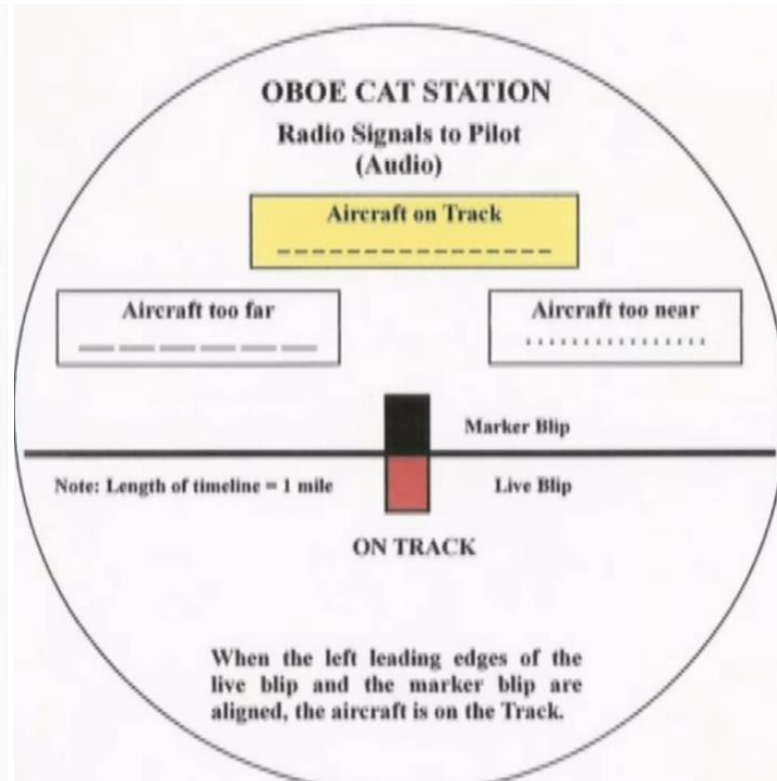
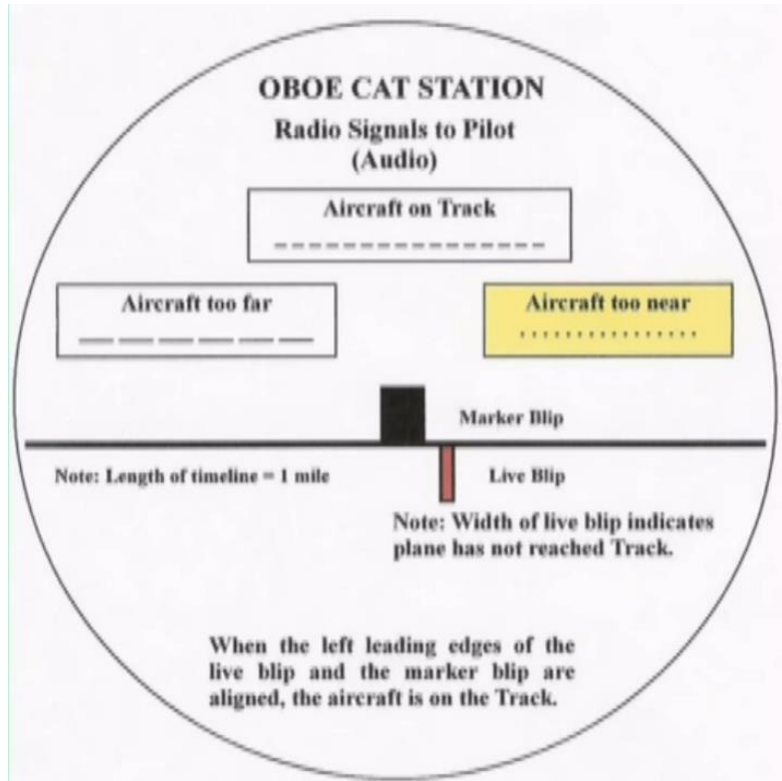

9 – OBOE SYSTEM

9.2 – Principles Behind “Oboe”

The Mouse Station operator’s job is to make sure you are dropping your bombs at the right time. The Mouse Station tracks you in a similar fashion as the Cat Station, but the Morse Code signals it will send you will be different and indicate how far you are from the target. This will, of course, require you to keep following the Track Arc, meaning that you have to be on the lookout for both the Cat and the Mouse signals.

Source: “OBOE - WWII Blind Bombing System (precursor to GEE)” by Jake Howland:
<https://youtu.be/hURdI91MCNQ>

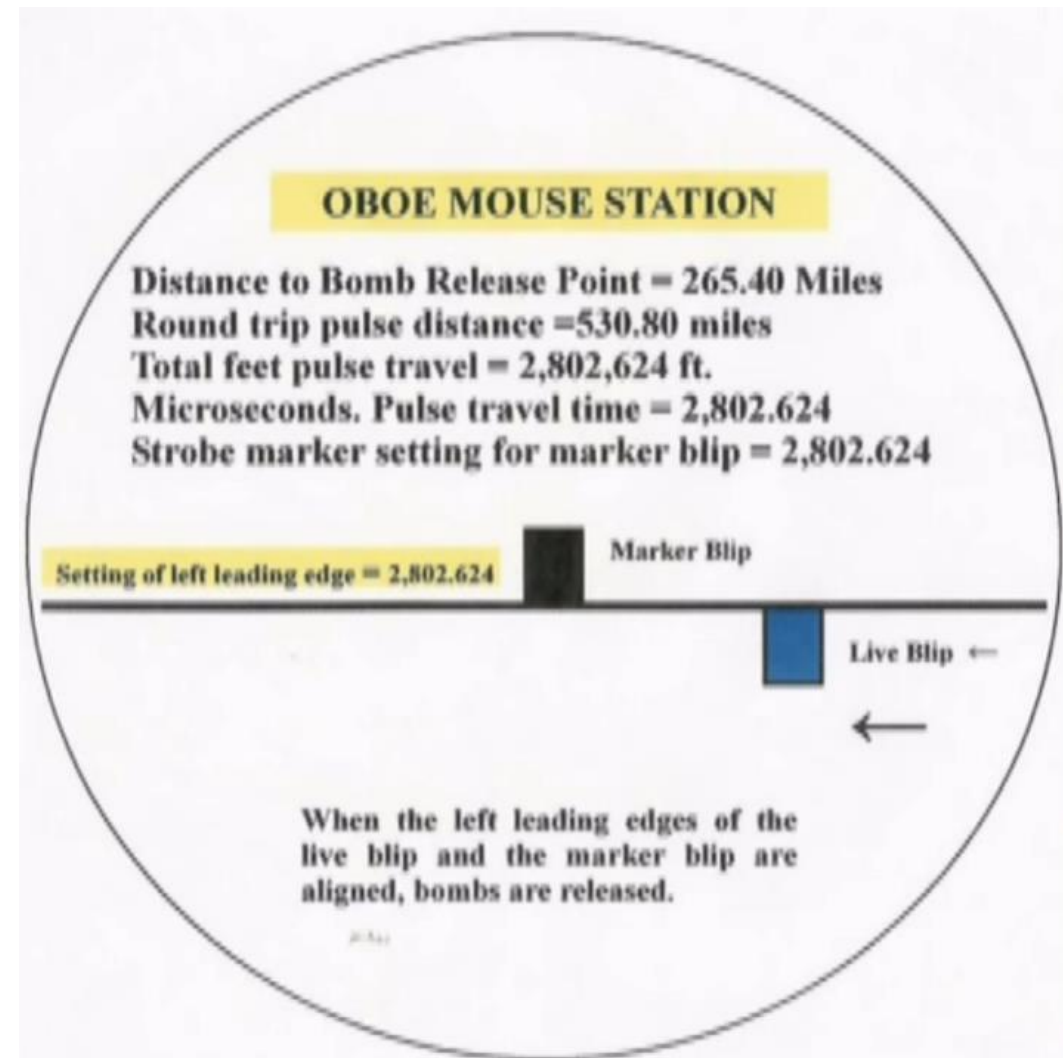



DH.98 MOSQUITO
FB MK VI

PART 12 – NAVIGATION

9 – OBOE SYSTEM

9.3 – Bombing Example with a Simulated “Oboe”



9 – OBOE SYSTEM

9.3 – Bombing Example with a Simulated “Oboe”

Here is an overview of the Mission Template we will use (by Draken35).
<https://forums.eagle.ru/topic/282986-oboe-mission-script-inside/>

Simplifications / Gameplay Concessions:

- Take note that the **Fighter-Bomber Mosquito variant we have in DCS is not equipped with a transponder compatible with “Oboe”**. The transponder was available for Bomber variants. As a work-around, the mission creator uses a series of scripts to simulate the transponder behavior.
- The “cat” and “mouse” station operators are simulated with mission scripts.
- In order to hear the morse code signals sent by the “cat” and “mouse” station operators, we will use the R1155 Radio Receiver with a custom frequency set to 18 MHz.
- This mission is not meant to be a perfect replication of an Oboe mission; it’s merely meant to give you an idea about the general principles behind it and how the pilot and navigator would figure out where they are and when to drop their bombs.

Oboe Demonstration Video by Reflected Simulations
<https://youtu.be/Vb0aa5nSbeU>

Note:

The Mission Template we use for this demonstration is from Draken35. The Mission Briefing (which includes the required altitude of 25000 ft and required airspeed of 210 mph) is taken from an Oboe mission adapted by Reflected Simulations.

Follow the track and, at 10 minutes from the target, a Morse code warning will be heard: AAAA. At 8 minutes it will be BBBB. At 6 minutes, CCCC. Then, at 3 minutes away another signal will be give: DDDD. The signal for bomb release point is 5T, which is 5 dots followed by a dash. Bombs should be release at the end of the dash. The "OBOE: Sound 'tutorial'" in COMMS menu will provide examples of these signals.

Release heading. At the time of this writing, it is not clear to the author when the pilot should turn into the release heading but as a best guess, since it is calculated from the release point to the target, is that the pilot should start turning into the release heading when the release signal starts.

Morse Signals

A = .-
 B = -...
 C = -.-.
 D = -..-
 5T =-
 X = -.-.-
 Y = -.-.-
 Z = -..-

BRIEFING



Oboe Mission Template
by Draken35

SITUATION

OBOE
Blind Bombing System
Script for DCS 2.7
by Draken35

Recommended reading and watching
<https://www.youtube.com/watch?v=hURdl91MCNQ>
<http://www.rquirk.com/cdnradar/cor/chapter13.pdf>

Principles of operations & script usage

The above links describe very well the principles of operation of OBOE, but in short, OBOE is a radar transponder based system used to measure distances from the plane to two ground stations: CAT and MOUSE.

Cat station is use to project a beam that pass over the target that the pilot must follow. Signaling is done with different sounds for when the plane is on track and short or long of it. Mouse station is used to control bomb release and signaling is Morse code. All the distances and important points are calculated in the ground prior to mission start and assuming the planes will fly in at a specific altitude and speed. These calculations will not be adjusted or corrected while in-flight, so it is very important to follow the flight profile.

In order to receive signals from the stations, the plane has to have line of sight with the stations. The altitude to maintain LOS is considered in the flight profile and LOS is modeled in this script. So, if you don't hear anything from Cat or Mouse, flight higher!

The script will pick a target (from an available list) and provide a briefing for the mission. The briefing consist of the target location and the flight profile used for the OBOE calculations and bomb release. The briefing also provides an attack direction (North -clockwise or South-counter clockwise in The Channel Map). In order to strike the target accurately, this flight profile and attack direction must be followed.

The first task is to intercept the track provided by the Cat station (steady tone on track, short pulses while short of track and long pulses for long of track) and turn into it from the attack direction provided in the briefing. You will heard a Morse X at 20 miles from the track, then a Morse Y at 10 miles and a Z at 5 miles from the track.

CANCEL

MISSION PLANNER

START

Use COMMS Menu (other) to access the OBOE Functions:

"OBOE: Mission Briefing":
Shows target and flight profile information

"OBOE: toggle on/off":
Toggles the OBOE equipment On and Off.

"OBOE: reset approach" :
The script keeps track of the 10min, 3 min and release signals and they are give only once This option allows for them to be reseted and the track flown again.

"OBOE: Report results"
Reports distance and position, using a clock face of the bombs impact in relation to the target. 6 o'clock is short, 12 is long, 3 is right and 9 is left.

"OBOE: Settings"
Allows to change the units in which the briefing and results are given and the accuracy of the system. The more accurate, the narrower the Cat beam is and the closer you need to get to the warning points in order to receive the corresponding signals.

"OBOE: Sound 'tutorial'" (Cat & Mouse)
Gives you the option to listen to all the sounds used by the script.

Mission editor:
In case you want to open the missions in the ME, the scripts and sounds are included in the respective folders. Just make sure to copy them to the places you normally use for those types of files.

9 – OBOE SYSTEM

9.3 – Bombing Example with a Simulated “Oboe”

1. Adjust cockpit lighting as required.
2. Use flashlight if needed (“LALT+L”).
3. Scroll mousewheel on the “Altimeter Barometric Pressure Setting” knob to set a standard barometric pressure of 1013.2 mBar. This is very important since barometric pressure settings are standardized at high altitudes, and this will affect your altimeter reading.
4. Fly the aircraft at an altitude of 25000 ft (as per briefing).
5. Fly the aircraft at an airspeed of 210 mph (as per briefing).
6. Turn on the Oboe scripts
 - a) Use the Radio Push-to-Talk Button (“RALT+\”)
 - b) Press “F10” to select the “Other” option
 - c) Press “F2” to toggle the Oboe ON
7. Operators on the Cat and Mouse stations will then send radio signals to you, and the transponder simulated by the script will then send back a response signal. From this information, the station operators will then be able to pinpoint your location based ON:
 - Your altitude (as briefed, which should be 25000 ft)
 - Your airspeed (as briefed, which should be 210 mph)

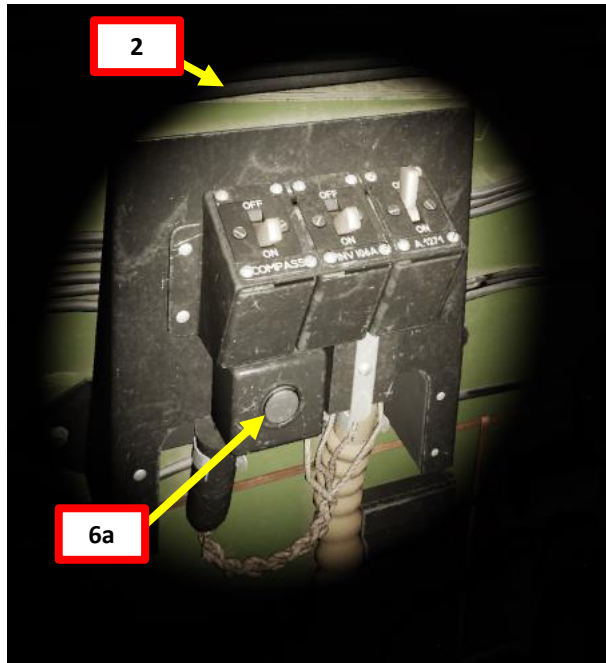
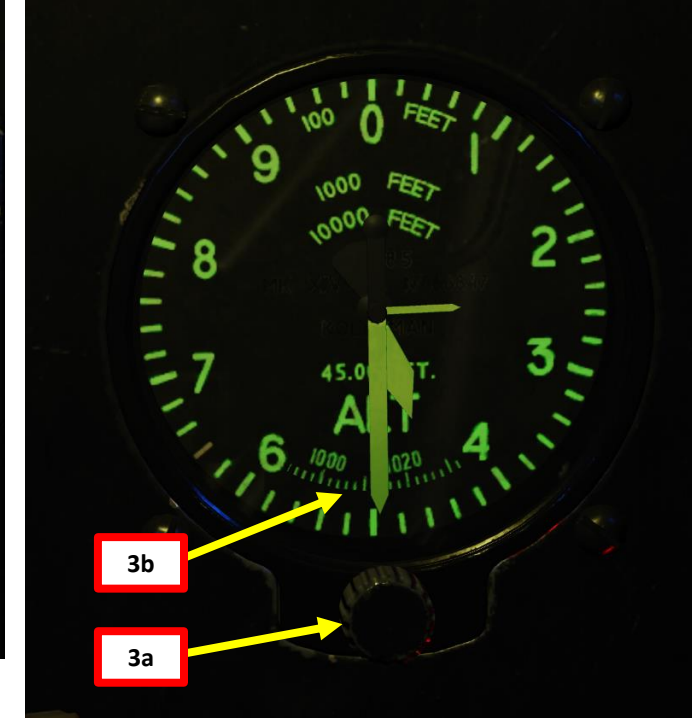

```

Main
F1. Wingman...
F2. Flight...
F3. Second Element...
F5. ATC...
F8. Ground Crew...
F10. Other...
F12. Exit
    
```

A red box labeled '6b' points to the 'F10. Other...' line.

```

2. Main. Other
F1. OBOE: Mission Briefing
F2. OBOE: toggle on/off
F3. OBOE: reset approach
F4. OBOE: Report results
F5. OBOE: Settings...
F6. OBOE: Sound 'tutorial' Cat...
F7. OBOE: Sound 'tutorial' Mouse...
F11. Previous Menu
F12. Exit
    
```

A red box labeled '6c' points to the 'F2. OBOE: toggle on/off' line.

```

OBOE is On
    
```

A red box labeled '6d' points to the 'OBOE is On' line.

9 – OBOE SYSTEM

9.3 – Bombing Example with a Simulated “Oboe”

8. Select the Navigator Seat by pressing “2”.
9. Set T1154 Radio Transmitter Low Voltage Power Switch – ON (LEFT)
10. Set T1154 Radio Transmitter High Voltage Power Switch – ON (LEFT)
11. Lower the armored headrest of the navigator seat to access the radio compartment by clicking on the headrest handle.
12. Turn on the Dome Light
13. Set T1154 Radio Transmitter Set Tuning Control knob to STD-BI (Standby) position.
14. Set Aerial (Antenna) Mode Selector – NORMAL

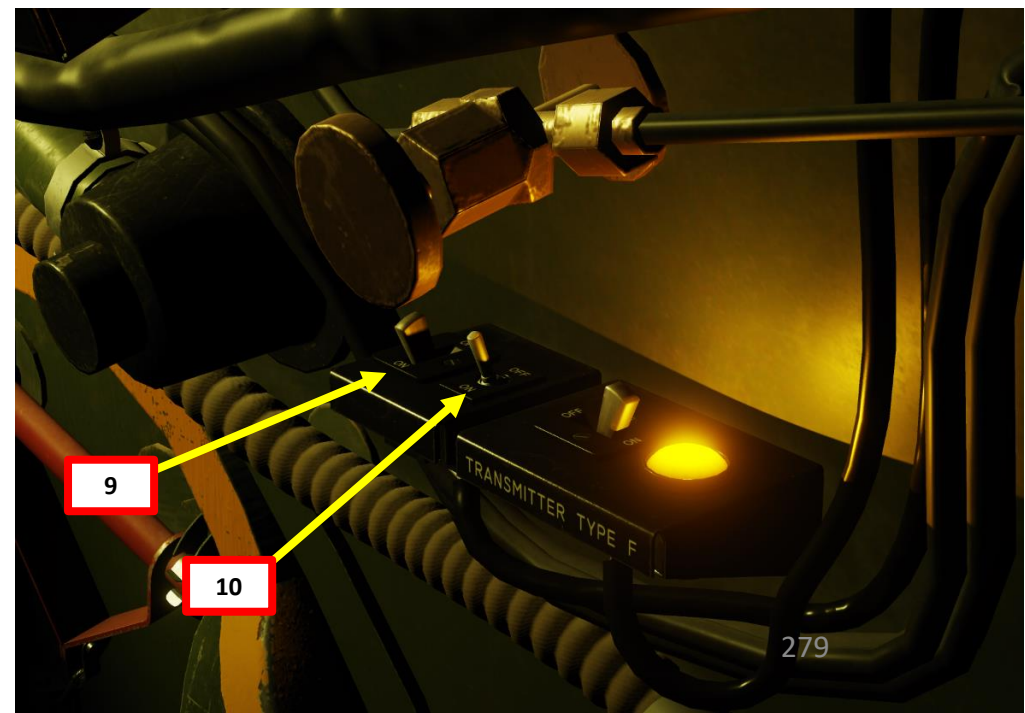
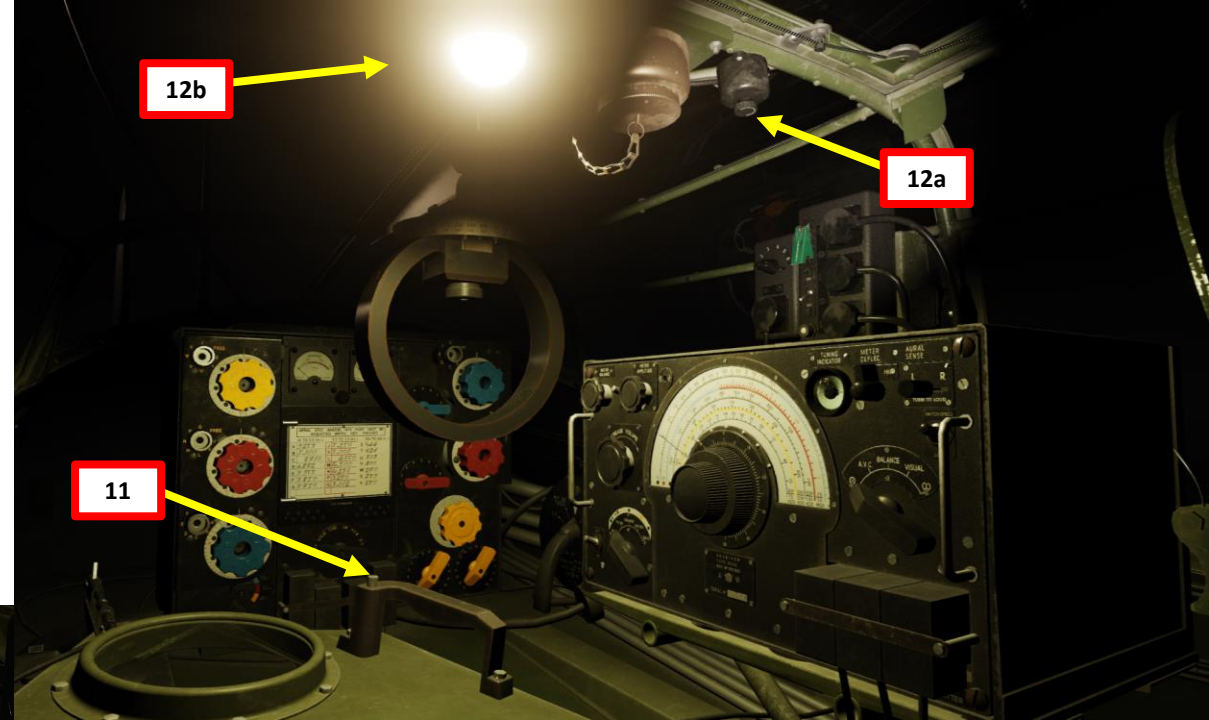

9 – OBOE SYSTEM

9.3 – Bombing Example with a Simulated “Oboe”

15. Set R1155 Radio Receiver Set Master Selector Switch – Omni (O)
16. Confirm that the Tuning Indicator Light illuminates
17. Set the R1155 Radio Receiver Set Frequency Range Switch to the appropriate frequency range (“18/7.5” for frequency 18 MHz).
18. Use tuning knobs to set radio frequency needle to the appropriate frequency (18 MHz). Since we use the 18/7.5 frequency range, we use the outermost band.
 - Use the outer tuning knob for coarse tuning (big needle movements) and the inner tuning knob for fine tuning (small needle movements).
19. Adjust Volume Control.
20. You should now be hearing a radio morse code signal which is made of a series of “dots”. This means that we have not reached the track arc yet, which is normal.

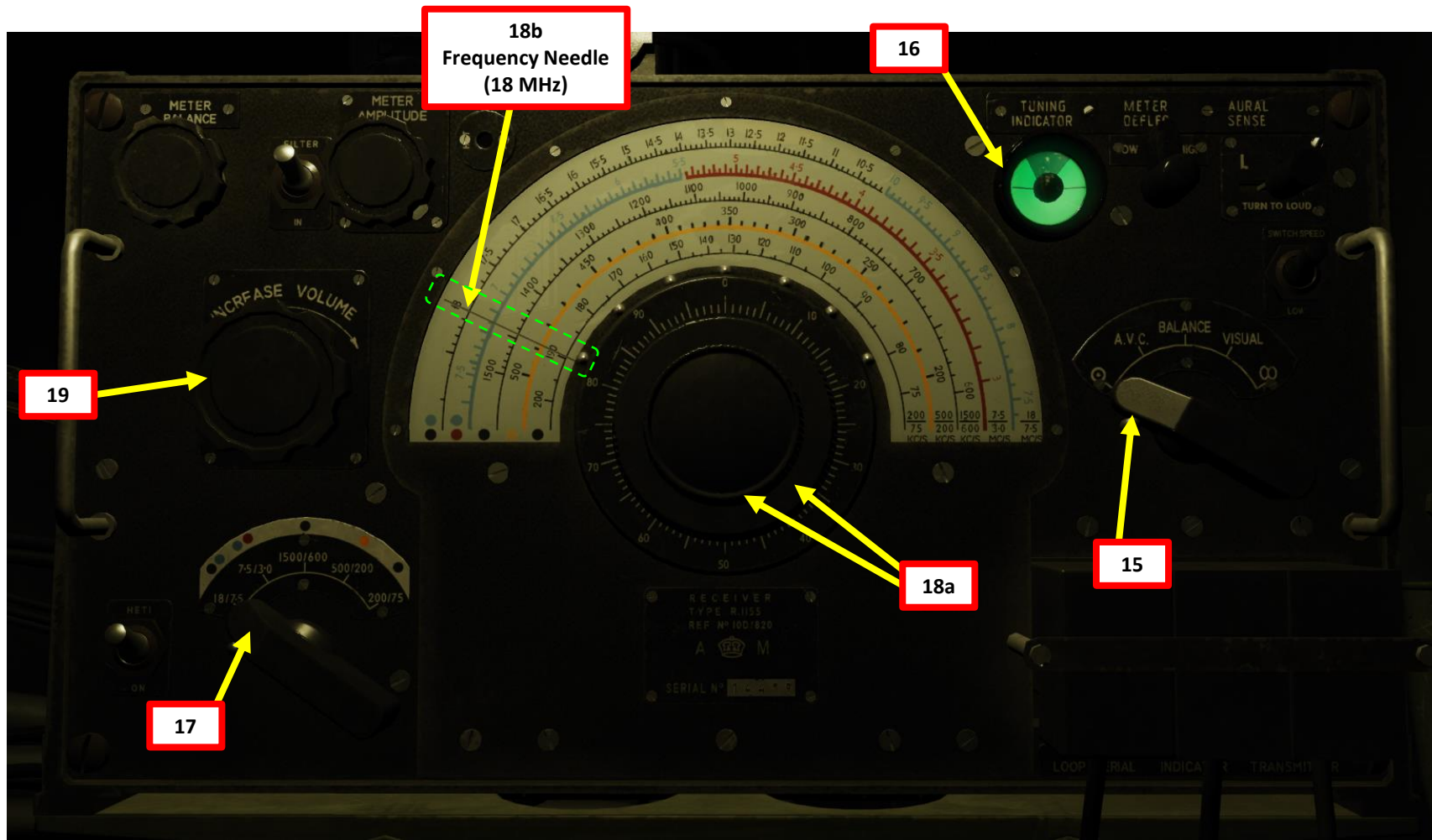

9 - OBOE SYSTEM

9.3 - Bombing Example with a Simulated "Oboe"

21. As you head Eastwards towards the Track Arc, the simulated transponder will receive and respond to the cat and mouse station signals. The station operators will then know where you are and send you appropriate Morse Code signals to tell you what your position is. **Make sure to maintain 25000 ft and 210 mph.**
22. As you approach the track line, you will hear a series of Morse "dots".
23. When you are 20 nm from the Track Arc, you will hear an audible "X" Morse Signal (*dash dot dot dash*) sent from the Cat station operator.
24. When you are 10 nm from the Track Arc, you will hear an audible "Y" Morse Signal (*dash dot dash dash*) sent from the Cat station operator.
25. When you are 5 nm from the Track Arc, you will hear an audible "Z" Morse Signal (*dash dash dot dot*) sent from the Cat station operator.



<u>DISTANCE FROM PATH</u>	<u>DISTANCE FROM TARGET</u>
X (-.-) 20 miles	S (...) IP
Y (-.-) 10 miles	A (.-) 10 min
Z (-.-) 5 miles	B (-..) 8 min
	C (-.-) 6 min - confirm ground speed
	D (-..) 3 min
- steady on 193°
	Release at the end of long dash

DISTANCE FROM PATH

23 X (-.-) 20 miles

24 Y (-.-) 10 miles

25 Z (-.-) 5 miles

9 – OBOE SYSTEM

9.3 – Bombing Example with a Simulated “Oboe”

26. Now, we have to intercept the Track Arc. **Make sure to maintain 25000 ft and 210 mph.**
27. When you have not yet intercepted the track, you will hear a series of Morse code “dots” from the Cat station operator.
28. When you have intercepted the track arc, you will hear a continuous, steady tone from the Cat station operator. Steer the aircraft to follow the track.
29. When you have gone past the track, you will hear a series of Morse code “dashes” from the Cat station operator.
30. Steer the aircraft based on the sound feedback from the Cat Station operator.
 - a) If you are heading South and start hearing Morse dashes, you are too far to the left of the track (relative to you). Steer right.
 - b) If you are heading South and start hearing Morse dots, you are too far to the right of the track (relative to you). Steer left.
 - c) A steady, continuous tone means you are on track. Keep current heading.

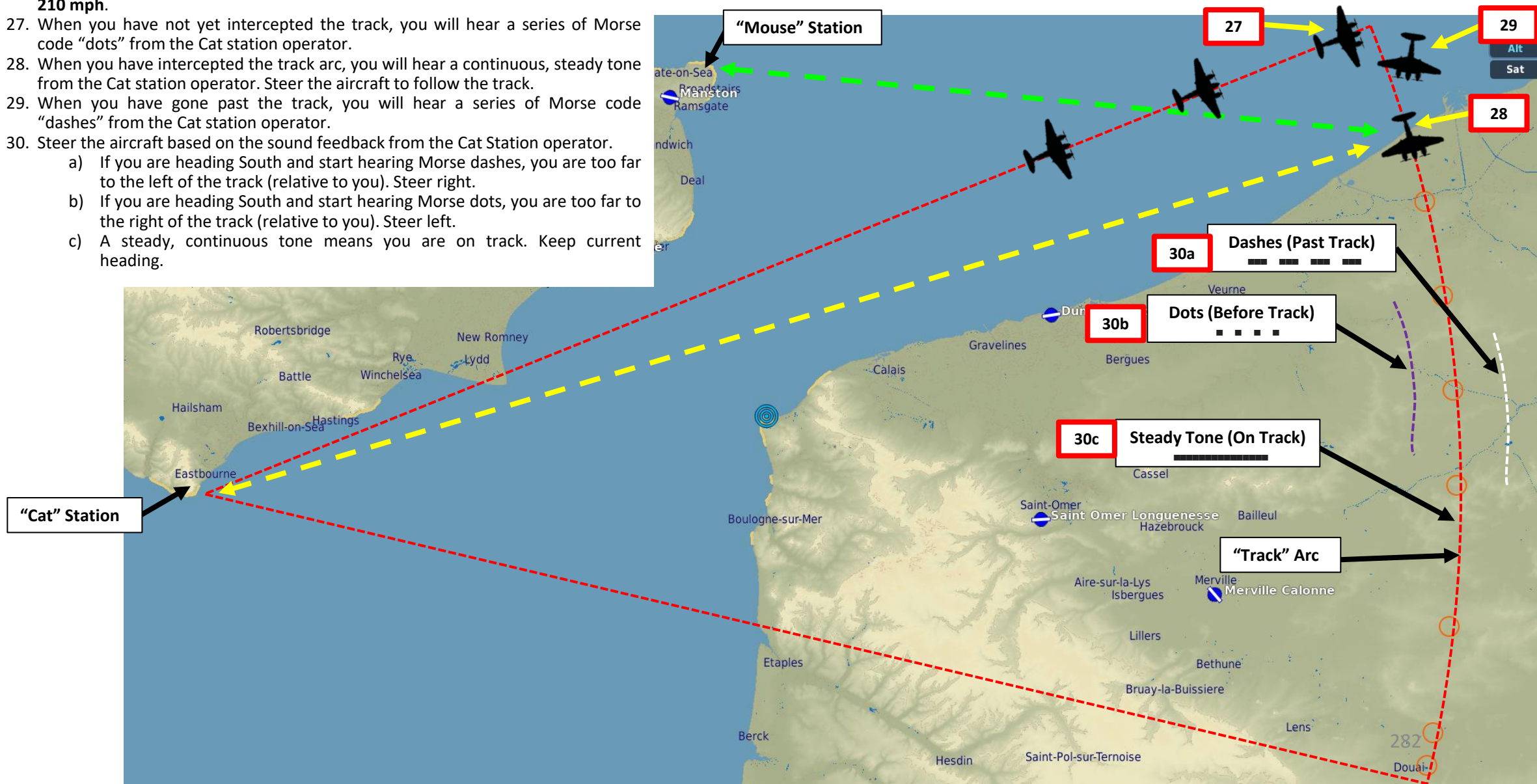

9 - OBOE SYSTEM

9.3 - Bombing Example with a Simulated "Oboe"

31. When you are over the Initial Point (which is on the Track Arc), you will hear an audible "S" Morse Signal (*dot dot dot*) sent from the Mouse station operator.
 - The steady continuous tone will also remain audible to continuously make sure you are following the track arc.
32. Once you have reached the IP (Initial Point), open bomb bay doors and arm bombs.

<u>DISTANCE FROM PATH</u>	<u>DISTANCE FROM TARGET</u>
X (---) 20 miles	S (...) IP
Y (-.-) 10 miles	A (-) 10 min
Z (---) 5 miles	B (-...) 8 min
	C (-.-) 6 min - confirm ground speed
	D (-..) 3 min
- steady on 193°
	Release at the end of long dash

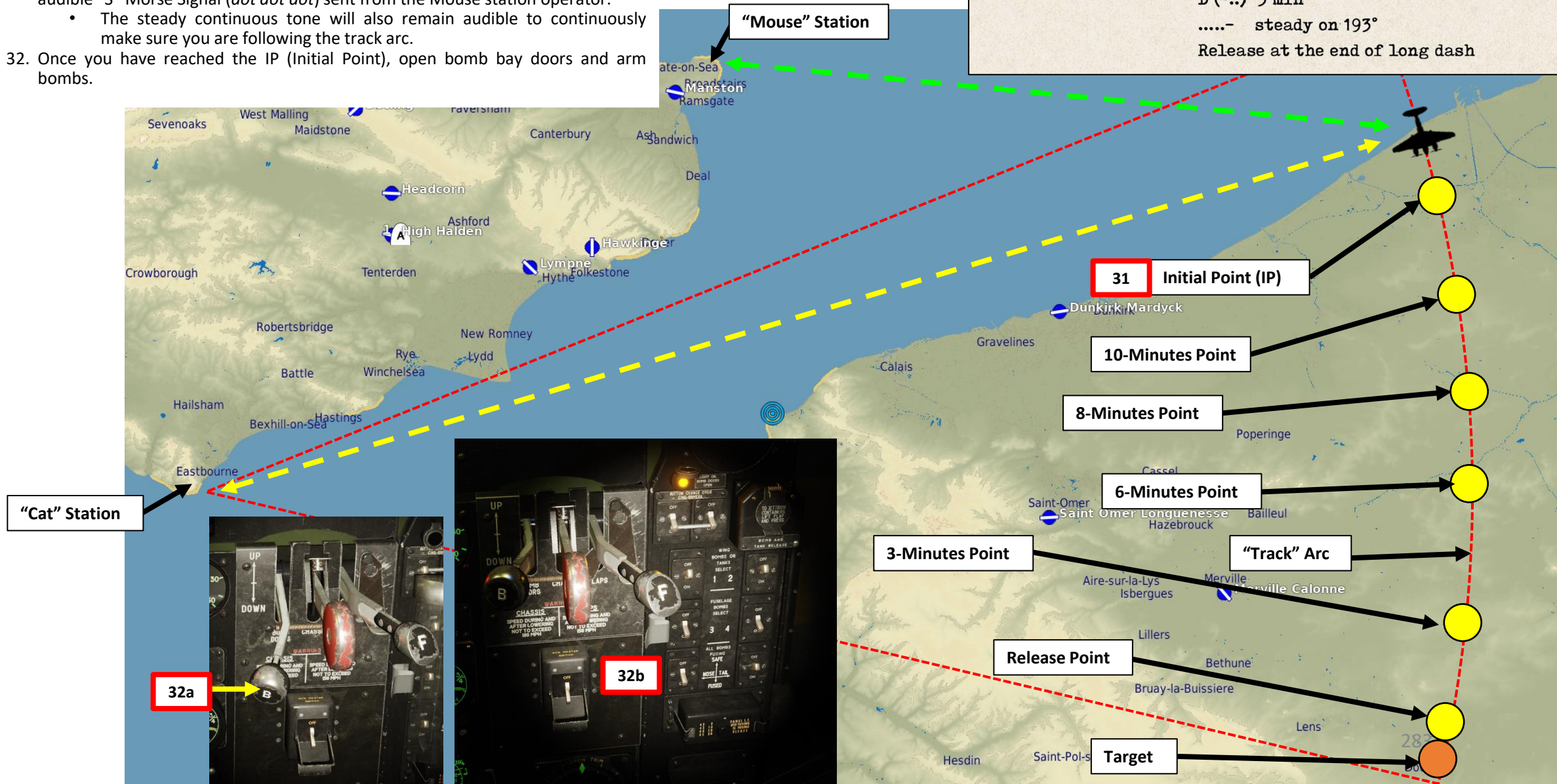

9 – OBOE SYSTEM

9.3 – Bombing Example with a Simulated “Oboe”

33. When you are over the 10-Minutes Point (which is on the Track Arc, 10 minutes of flight time away from the target if you fly at 210 mph and 25000 ft), you will hear an audible “A” Morse Signal (*dot dash*) sent from the Mouse station operator.
34. When you are over the 8-Minutes Point (which is on the Track Arc, 8 minutes of flight time away from the target if you fly at 210 mph and 25000 ft), you will hear an audible “B” Morse Signal (*dash dot dot dot*) sent from the Mouse station operator.
35. When you are over the 6-Minutes Point (which is on the Track Arc, 6 minutes of flight time away from the target if you fly at 210 mph and 25000 ft), you will hear an audible “C” Morse Signal (*dash dot dash dot*) sent from the Mouse station operator. At this point, you should be checking your airspeed.
36. When you are over the 3-Minutes Point (which is on the Track Arc, 3 minutes of flight time away from the target if you fly at 210 mph and 25000 ft), you will hear an audible “D” Morse Signal (*dash dot dot*) sent from the Mouse station operator. At this point, you should keep following the Track.
37. The steady continuous tone will also remain audible to continuously make sure you are following the track arc.

<u>DISTANCE FROM PATH</u>	<u>DISTANCE FROM TARGET</u>
X (-.-) 20 miles	S (...) IP
Y (-.-) 10 miles	A (-) 10 min
Z (-.-) 5 miles	B (-...) 8 min
	C (-.-) 6 min - confirm ground speed
	D (-..) 3 min
- steady on 193°
	Release at the end of long dash

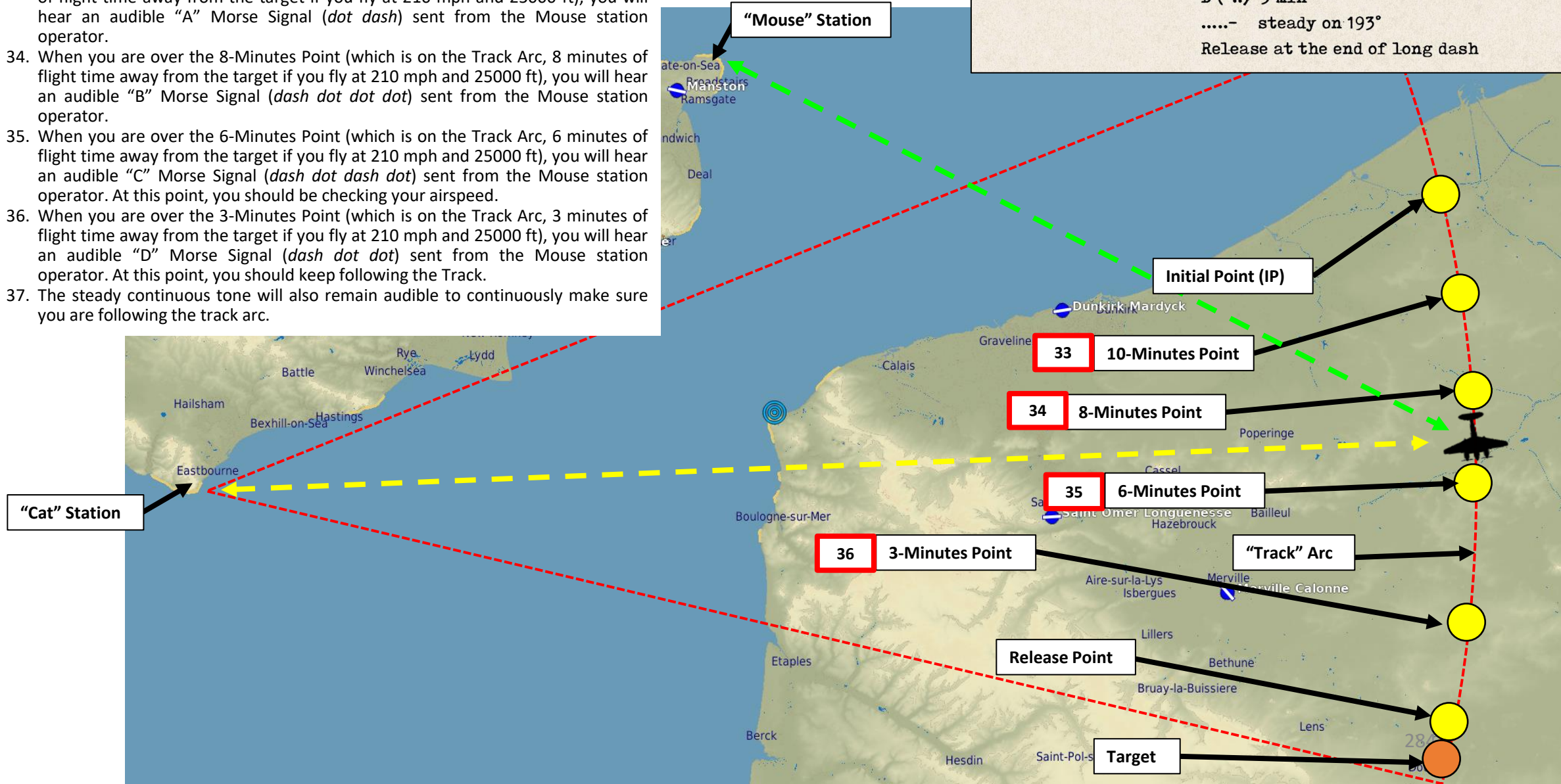

9 - OBOE SYSTEM

9.3 - Bombing Example with a Simulated "Oboe"

- 38. When you are over the Release Point, you will hear the Release Signal, a series of Morse code dots sent from the Mouse station operator, which will be sent for 7.5 seconds. During this time, make a heading correction to fly to a heading of 193.
- 39. When the Release Signal switches from dots to a dash (long tone), release your bombs and head back to base.

<u>DISTANCE FROM PATH</u>	<u>DISTANCE FROM TARGET</u>
X (-.-) 20 miles	S (...) IP
Y (-.-) 10 miles	A (-) 10 min
Z (-.-) 5 miles	B (-...) 8 min
	C (-.-) 6 min - confirm ground speed
	D (-.-) 3 min
- steady on 193°
	Release at the end of long dash

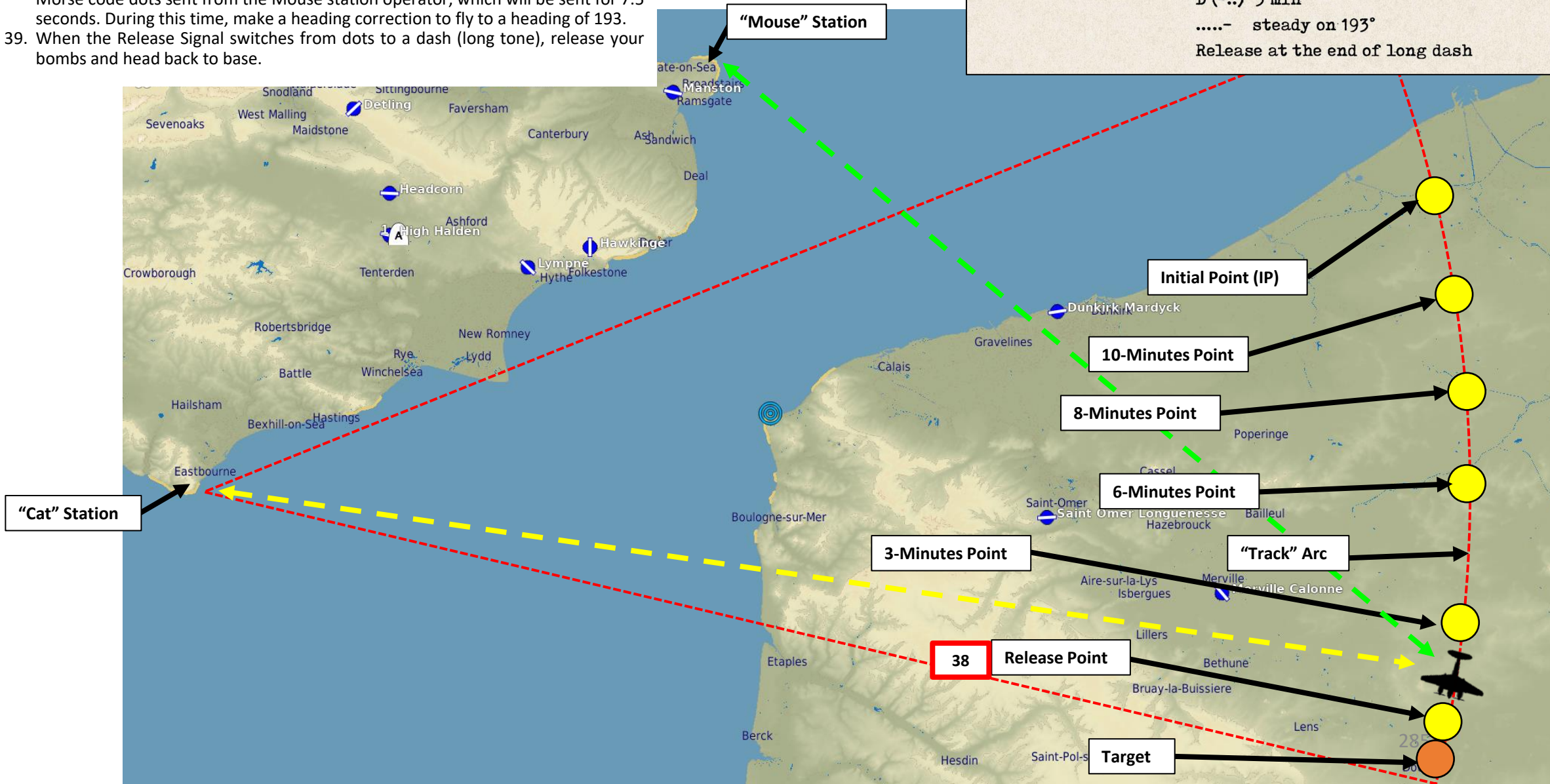



DH.98 MOSQUITO
FB MK VI

PART 12 – NAVIGATION

9 – OBOE SYSTEM

9.3 – Bombing Example with a Simulated “Oboe”





DH.98 MOSQUITO
FB MK VI

PART 13 – EMERGENCY PROCEDURES





ENGINE FAILURE DURING TAKEOFF

1. If an engine failure occurs during takeoff, handling characteristics differ considerably according to the aircraft weight. At a weight of approx. 17000 lbs, the safety speed should be assumed to be 180 mph at +9 psi boost, or 195 mph at +18 psi boost if engines have not been de-rated).
2. Once aircraft is accelerating beyond safety speed, the aircraft will climb away on one engine at climbing power at about 155 – 160 mph provided that:
 - a) Propeller of the failed engine is feathered (minimizes drag)
 - b) Radiator shutter of the failed engine is closed (minimizes drag)
 - c) Flaps are fully up (Retracted)
3. The drag of a windmilling propeller is very high and unless feathering action is taken immediately, control can be maintained at the expense of a rapid loss in height.
4. The aircraft accelerates slowly to the safety speed at +18 psi boost. If high power is used for takeoff, it is recommended that climbing power is used as soon after takeoff as is possible.

ENGINE FAILURE IN FLIGHT

1. When engine failure occurs in flight, immediately close the throttle of the failed engine.
2. Feather the propeller of the failed engine.
3. Close the radiator shutter of the failed engine.
4. Open the radiator shutter of the live engine and keep a careful watch on the temperature of the live engine.
5. At full load, height can be maintained on either engine up to 12000 ft using climbing power at about 170 mph.

Although it is a natural desire among pilots to save an ailing engine with a precautionary shutdown, the engine should be left running if there is any doubt as to needing it for further safe flight. Catastrophic failure accompanied by heavy vibration, smoke, blistering paint, or large trails of oil, on the other hand, indicate a critical situation. The affected engine should be feathered and the Securing Failed Engine checklist completed. The pilot should divert to the nearest suitable airport and declare an emergency with ATC (Air Traffic Controller) for priority handling.





AIRCRAFT HANDLING WITH ONE ENGINE OPERATING

Not all engine power losses are complete failures. Sometimes, the failure mode is such that partial power may be available. If there is a performance loss when the throttle of the affected engine is retarded, the pilot should consider allowing it to run until altitude and airspeed permit safe single-engine flight, if this can be done without compromising safety. Attempts to save a malfunctioning engine can lead to a loss of the entire airplane.

When flying with a single engine, I have three general rules / memory aids you can use to maintain control of the aircraft:

- #1: **“Turn in the dead engine, you die.”** You want to turn in the direction of the live engine, NOT in the direction of the dead engine. Failing to do so may cause the aircraft to enter an unrecoverable spin. This aspect is important to remember in case you need to perform a pattern at an airfield.
- #2: **“Dead foot, dead engine”** is used to assist in identifying the failed engine. You want to minimize aircraft slip as much as possible. Depending on the engine failure mode, the pilot might not be able to consistently identify the failed engine in a timely manner from the boost or RPM gauges. In maintaining directional control, however, rudder pressure is exerted on the side of the airplane with the operating engine. Thus, the “dead foot” is on the same side as the “dead engine.” Variations on this saying include “idle foot, idle engine” and “working foot, working engine.”
- #3: **“Raise the dead”** is a reminder that the best climb performance is obtained with a very shallow bank, about 2 to 3 deg toward the operating engine. Therefore, the inoperative, or “dead” engine should be “raised” with a very slight bank.

Single Engine Failure Emergency Video by Reflected Simulations:
<https://youtu.be/7sMmFTOnH3E>

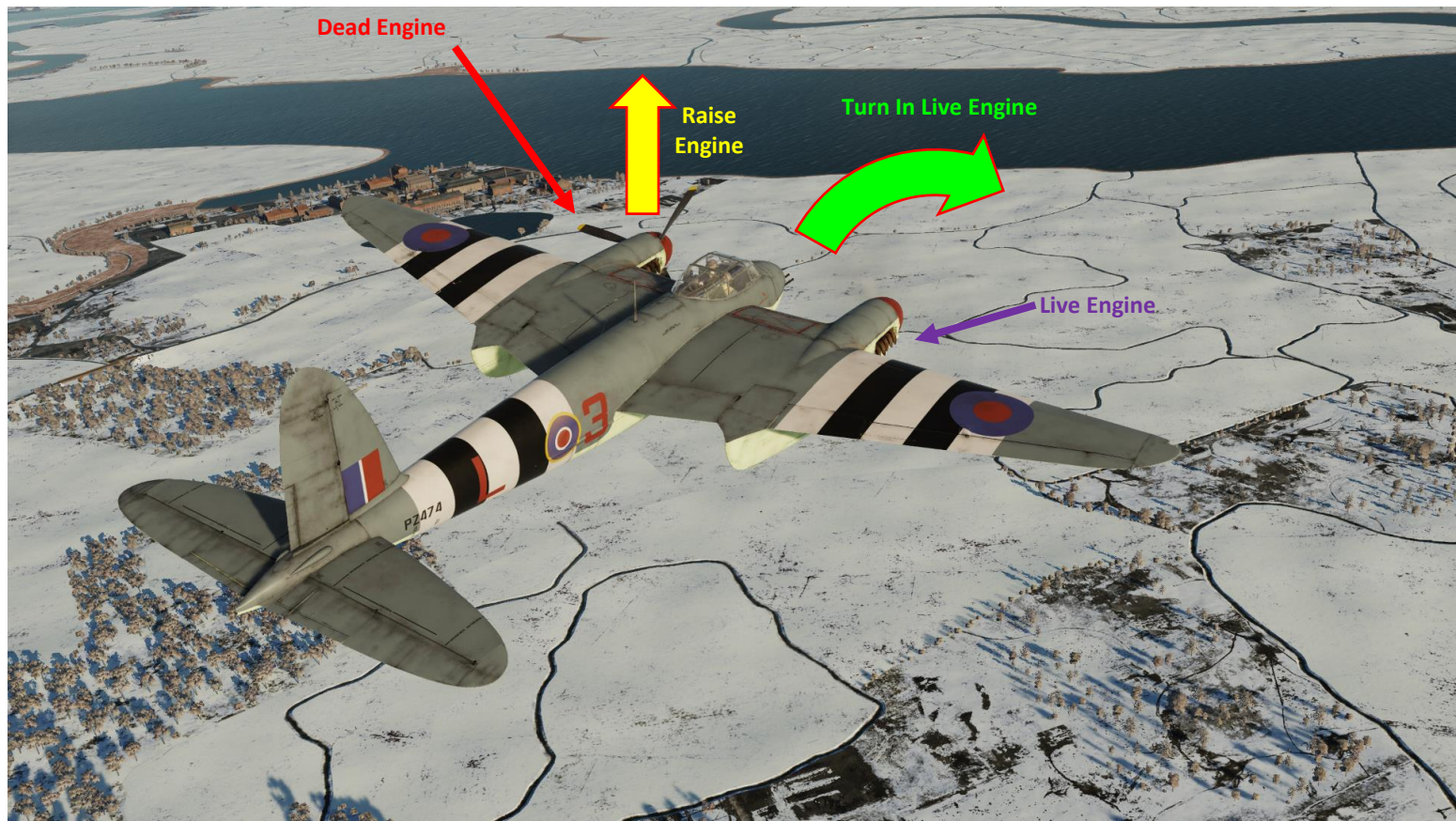



SINGLE ENGINE LANDING

1. If landing with a single engine, verify that the dead engine propeller is feathered in order to minimize drag.
2. While manoeuvring with the flaps and undercarriage up, a speed of 160 – 170 mph should be maintained
3. A normal circuit can safely be made irrespective of which engine has failed. The checks before landing should be carried out as for a normal landing, but it should be remembered that the undercarriage will take longer to lower on one engine (approximately 30 seconds at 2850 RPM). Also, owing to the landing gear's high drag, height will be lost once it has started to lower.
4. When across wind, flaps may be lowered 15 deg and the live engine used carefully to regulate the rate of descent.
5. Speed should not be allowed to fall below 155 mph until it is clear that the airfield is within easy reach.
6. Flaps may be lowered further as required and power and speed reduced as height is lost, aiming to cross the airfield boundary at the speeds quoted for an engine assisted landing.

GO-AROUND ON ONE ENGINE

1. Going round again is only possible if the decision is made while ample height remains and before more than 15 deg of flap is lowered. The height is required in order to maintain the speed above the critical speed, for the high power necessary, while the undercarriage and flaps are retracting.
2. When the decision to go around again has been made:
 - a) Ensure that the speed is not less than 155 mph, and then increase power on the live engine to + 9 psi boost and 2850 RPM
 - b) Raise the undercarriage
 - c) Increase speed to 160 – 170 mph
 - d) Raise the flaps and re-trim
 - e) Power higher than + 9 psi boost should only be applied carefully and within the limits of rudder control.



Feathering Button (Left Propeller)

- Feathers propeller to reduce drag when engine is shut down while in-air

Feathering Button (Right Propeller)

- Feathers propeller to reduce drag when engine is shut down while in-air





UNDERCARRIAGE & FLAPS EMERGENCY OPERATION

1. If the undercarriage has lowered but not locked down:

- Re-select DOWN, check that the selector lever returns to neutral, and check the position of the undercarriage by the indicator and warning horn.
- If the undercarriage is still not locked down, but the selector lever springs back to neutral, this indicates functioning of the hydraulic pumps, but no positive operation of the undercarriage down locks.
- Leave the selector in the neutral position until the flaps have been lowered, then take every opportunity of holding the undercarriage selector in the DOWN position.
- After landing, hold the selector in the DOWN position until the units can be locked by the ground crew. Until this has been done, avoid raising the flaps, taxiing, turning or using the brakes.

2. If the indicator fails to show that the undercarriage is locked down, and the selector lever does not spring back to neutral:

- Return the selector lever to neutral and push the emergency knob down. Operate the handpump until the indicator shows that the wheels are locked down, or until considerable resistance is felt for several strokes. This however, will not lower the tailwheel.
- Return emergency knob to the UP position. Put the flap selector lever DOWN and handpump until the flaps are 15 deg down. Then, return the selector lever to neutral.
- Select undercarriage DOWN, and use the handpump in an attempt to lower the tailwheel. Increased resistance to the handpump indicates when the operation is complete.
- Lower the flaps fully, or as required, using the handpump. Return the flaps selector lever to neutral.
- If the main wheels fail to lock down, or to remain locked down, push the emergency knob down again and maintain pressure on the undercarriage by using the handpump during the landing.

Hydraulic Hand Pump Socket

Note: The hand pump handle is under the pilot seat and has to be screwed in the socket. Hand-pumping the landing gear down takes 4 minutes to build up enough pressure to successfully deploy and lock the landing gear for landing.



Hydraulic Hand Pump Handle



FLAPLESS LANDING

1. The approach with flaps up is very flat, and difficulty may be experienced in maintaining a steady airspeed.
2. At the maximum landing weight, the final approach should be made at 130 mph. At light loads, this speed may be reduced by 6 mph.
3. Touchdown is straightforward and the landing run, although lengthened, does not become excessive.





ENGINE FIRE

The engine fire-extinguisher buttons are used to release a chemical extinguishing agent if an engine fire is selected.

Note: Fire extinguishers operate automatically in the event of a crash.



Fire Extinguisher Pushbutton
Portside (Left) Engine

Fire Extinguisher Pushbutton
Starboard (Right) Engine



MULTICREW

The Mosquito can only be flown by the pilot, but an additional player can take the navigator seat in multiplayer. However, you need to go in the Mission Editor and make sure the Mosquito is set up in the following manner:

1. Select Mosquito Unit and go in “Additional Properties for Aircraft” menu
2. Make sure “Solo Flight” option is not ticked
3. When spawning in multiplayer in any seat, the pilot will receive a request to let you take control of the other seat.

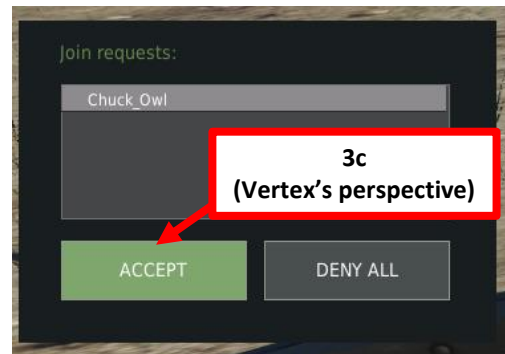
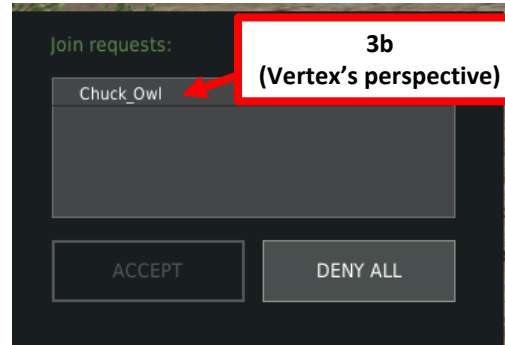

MULTIPLAYER - Select role

Spectators		BLUE COALITION	1 players	PLAYERS POOL	Chuck_Owl	
Group	Unit Type	Position	Country	#	Airfield	Player
Mosquito-12	Mosquito FB Mk. VI	Pilot	UK	022	Needs Oar Point	
		Observer	UK	022	Needs Oar Point	
Mosquito-13	Mosquito FB Mk. VI	Pilot	UK	023	Needs Oar Point	
		Observer	UK	023	Needs Oar Point	
Mosquito-16	Mosquito FB Mk. VI	Pilot	UK	026	Maupertus	Vertex
		Observer	UK	026	Maupertus	
Mosquito-17	Mosquito FB Mk. VI	Pilot	UK	027	Maupertus	
		Observer	UK	027	Maupertus	
Mosquito-18	Mosquito FB Mk. VI	Pilot	UK	028	Maupertus	
		Observer	UK	028	Maupertus	
Mosquito-19	Mosquito FB Mk. VI	Pilot	UK	029	Maupertus	
		Observer	UK	029	Maupertus	
Mosquito-2	Mosquito FB Mk. VI	Pilot	UK	012	Needs Oar Point	
		Observer	UK	012	Needs Oar Point	
Mosquito-22	Mosquito FB Mk. VI	Pilot	UK	032	Maupertus	
		Observer	UK	032	Maupertus	
Mosquito-23		Pending request to	UK	033	Maupertus	
		Vertex	UK	033	Maupertus	
Mosquito-3			UK	013	Needs Oar Point	

Cancel

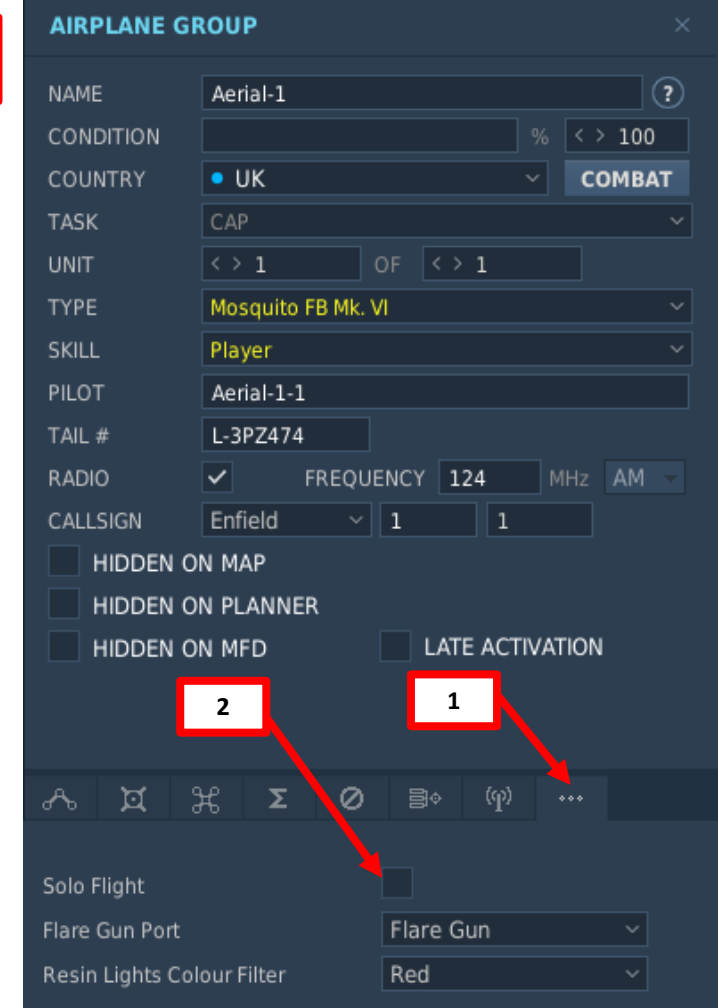



DH.98 MOSQUITO
FB MK VI

MULTICREW

Take note that the navigator does not have any flight controls; only the pilot can fly the aircraft. However, only the navigator can use the T1154 Radio Transmitter and R1155 Radio Receiver sets.

MULTIPLAYER - Select role

Spectators		BLUE COALITION				2 players		PLAYERS POOL		Chuck_Owl	
Group	Unit Type	Position	Country	#	Airfield	Player					
Admin LFDM	Mosquito-12	Mosquito FB Mk. VI	Pilot	UK	022	Needs Oar Point					
			Observer	UK	022	Needs Oar Point					
	Mosquito-13	Mosquito FB Mk. VI	Pilot	UK	023	Needs Oar Point					
			Observer	UK	023	Needs Oar Point					
	Mosquito-16	Mosquito FB Mk. VI	Pilot	UK	026	Maupertus	Vertex				
			Observer	UK	026	Maupertus	Chuck_Owl				
	Mosquito-17	Mosquito FB Mk. VI	Pilot	UK	027	Maupertus					
			Observer	UK	027	Maupertus					
	Mosquito-18	Mosquito FB Mk. VI	Pilot	UK	028	Maupertus					
			Observer	UK	028	Maupertus					
	Mosquito-19	Mosquito FB Mk. VI	Pilot	UK	029	Maupertus					
			Observer	UK	029	Maupertus					
	Mosquito-2	Mosquito FB Mk. VI	Pilot	UK	012	Needs Oar Point					
			Observer	UK	012	Needs Oar Point					
	Mosquito-22			UK	032	Maupertus					
				UK	032	Maupertus					
	Mosquito-23			UK	033	Maupertus					
				UK	033	Maupertus					
	Mosquito-3			UK	013	Needs Oar Point					
				UK	013	Needs Oar Point					
		Access granted by Vertex									
Group	Unit Type	Position	Country	#	Airfield	Player					
13/JG51 190 D9			NZG	28	Carpiquet						
13/JG51 190 D9-1		Fw 190 D-9	NZG	28	Carpiquet						

PART 14 – MULTICREW



DH.98 MOSQUITO
FB MK VI

PART 15 - TACTICS & AIR COMBAT





HANDLING QUALITIES

The Mosquito is one of the most versatile aircraft of the Second World War mission-wise. It could be used as a heavy fighter, a fighter-bomber, a bomber, a reconnaissance aircraft, a pathfinder... but keep in mind that the Mosquito's main advantage was its speed. It wasn't meant to be a dogfighter like the Spitfire; it was built to avoid enemy fighters and outrun them. Therefore, the best way to fly the Mossie is to make sure that you do not lose airspeed unless you really, really have to.

While the Mosquito packs an impressive amount of firepower, it was limited in some regards by what it could do effectively. Here are some conclusion from a 1943 flight test report that highlights the Mosquito's handling qualities.

- The Mosquito has very good controls but the presence of the inertia weight detracts from the aircraft's general maneuverability as a fighter.
- With Merlin 23 engines, it is about the same speed as the FW190 at sea level, faster at 9000 ft, but slower than the Bf109 at 17000 ft. (Note: the Mosquito FB VI in DCS has the Merlin 25, which has more horsepower and is optimized for low altitude flight).
- The climb of the Mosquito is considerably slower than that of enemy fighters.
- The acceleration to the dive is good and the limiting speed (450 mph) quickly obtained.
- Against single seater fighters, the Mosquito could hardly ever get on to the offensive and was unable to disengage when the fighters were in position astern.
- The Mosquito is an excellent intruder but limited by the difficulty of searching aft satisfactorily to prevent being jumped.
- As a fighter-bomber, the Mosquito can be used effectively against similar targets to these engaged by the Hawker Typhoon.
- As a long-range fighter, the Mosquito is considered the best available aircraft of the type and can be very effective against enemy bomber or reconnaissance aircraft.
- As an escort fighter, the Mosquito is not considered effective owing to its limited powers of offence. It would probably be a liability to a bomber force.





GENERAL AIR COMBAT RULES

If push comes to shove, fighting in the Mosquito is an art that is difficult against a pilot who knows what he is doing. Here are a few rules I recommend you follow:

- Rule No. 1 – If you can run away... run away. The Mosquito's biggest strength is its speed. Your aircraft isn't designed to do the fancy turn-and-burn of the Spitfire.
- Rule No. 2 – If flying with a player-controlled navigator, make sure he checks your rear every 30 seconds or so. The visibility in the Mosquito is great at the front but rather poor at the back, especially with all the radio equipment taking space.
- Rule No. 3 – If you have a firing solution, take the shot. The Mosquito's firepower will shred anything that crosses your reticle. Since your aircraft isn't the most manoeuvrable, it is advised to engage enemy fighters that are either outnumbered or on the defensive, which allows you to sneak up on an unsuspecting Hun.
- Rule No. 4 – Use low altitude flight to your advantage. Staying low makes it easier to escape and allows you to use terrain or ground clutter to mask your location.
- Rule No. 5 – If you are dogfighting, keep your energy state high (e.g. airspeed) at all times. This principle applies to every single aircraft, but particularly to the Mosquito since it suffers in manoeuvrability.
- Rule No. 6 – Do not attempt to outclimb or outdive a 109 or 190 unless you have a serious energy advantage.
- Rule No. 7 – Always fly with a wingman. This is the best way to operate since you can use a wingman to lure someone into your gunsight, and vice-versa.
- Rule No. 8 – Master your aircraft: know your engine limits and airspeed limits by heart and practice manoeuvres to avoid stalls and spins.



BAG THE HUN

One of the best resources for “bagging those hunns” is actually a document of the same name.

Here is a link to a pdf scan of this manual: <https://drive.google.com/open?id=0B-uSpZROuEd3V25mRIE2TDMzcXc>



FOR OFFICIAL USE ONLY

A.P. 2580 A

Bag the Hun!

Prepared by direction of the Minister of Aircraft Production

A. P. Rowlands

Promulgated by order of the Air Council

[Signature]

AIR MINISTRY
April 1943

Revised, incorporating minor corrections
November, 1943



USEFUL RESOURCES

Reflected Simulations Mosquito Tutorial Series (Youtube)

- Start-Up, Takeoff & Landing: <https://youtu.be/S8aa9d4geDs>
- Radios and Navigation: <https://youtu.be/tGXSLKSiRk>
- Night Flying: <https://youtu.be/16o9ZyqP-g>
- Mosquito Oboe Tutorial: <https://youtu.be/Vb0aa5nSbeU>
- RAF Lingo & Codewords Explained: <https://youtu.be/S1JItKfoNlg>

SUNTSAG Mosquito Video Tutorial Series (Youtube)

<https://www.youtube.com/playlist?list=PL56M8zQ0bxUPDYc5O9yFmewanpR3jILF->

WWII Documentary: The Mosquito | The Legendary Aircraft Of WWII (Youtube)

<https://youtu.be/8vpzpOVJ6H8>

Mosquito FB VI Pilot Notes

Eagle Dynamics (Official Developer) Work-In-Progress Early Access Guide

https://www.digitalcombatsimulator.com/en/downloads/documentation/mosquito_manual_en/

Pathfinder Craig - Pathfinder Methods

<https://masterbombercraig.wordpress.com/bomber-command-structure/no-8-pff-group-bomber-command/pathfinder-force-pff/pathfinder-methods/>

Making It Up – WW2 Signals Spectrum – A Quick Survey

<http://play.fallows.ca/wp/radio/shortwave-radio/ww2-signals-spectrum-detail/>

Night Bombers (1945)

<https://youtu.be/xAztJVoBTKE>

Design Analysis No. 6, DeHavilland Mosquito – By Chester S Ricker, Detroit Editor, Aviation

http://legendsintheirowntime.com/LiTOT/Mosquito/Mosquito_Av_4405-06_DA.html

Terror In the Starboard Seat – By Dave McIntosh

A great book from a Canadian Mosquito navigator.



MORSE CODE REFERENCE

International Morse Code

1. The length of a dot is one unit.
2. A dash is three units.
3. The space between parts of the same letter is one unit.
4. The space between letters is three units.
5. The space between words is seven units.

A	• —	U	• • —
B	— • • •	V	• • • —
C	— • — •	W	• — —
D	— • •	X	— • • —
E	•	Y	— • — —
F	• • — •	Z	— — • •
G	— — •		
H	• • • •		
I	• •		
J	• — — —		
K	— • — —		
L	• — • •		
M	— —		
N	— •		
O	— — —		
P	• — — •		
Q	— — • —		
R	• — •		
S	• • •		
T	—		
		1	• — — — —
		2	• • — — —
		3	• • • — —
		4	• • • • —
		5	• • • • •
		6	— • • • •
		7	— — • • •
		8	— — — • •
		9	— — — — •
		0	— — — — —

THANK YOU TO ALL MY PATRONS

Creating these guides is no easy task, and I would like to take the time to properly thank every single one of my [Patreon](#) supporters. The following people have donated a very generous amount to help me keep supporting existing guides and work on new projects as well:

- [ChazFlyz](#)
- Jacob “Cub” Pilch-Bisson



MOSQUITO FBVI

- INSTANT ACTION
- CREATE FAST MISSION
- MISSION
- CAMPAIGN
- MULTIPLAYER

- LOGBOOK
- ENCYCLOPEDIA
- TRAINING
- REPLAY

- MISSION EDITOR
- CAMPAIGN BUILDER

EXIT



Fw 190 A-8
EA



Fw 190 D-9
EA



I-16
beta



JF-17
EA



Ka-50
EA



L-39
EA



M-2000C
2.7.x



Marianas
EA



MI-24P
EA



MI-8MTV2
EA



MIG-15bis
EA



MIG-19P
Dev 2.5.x



MIG-21bis
trunk



Mosquito FB
Mk. VI



Normandy
EA



P-47D-30
EA



P-51D
EA